

Test Booklet Code

No. :

GAJAH

M1

This Booklet contains 28 pages.

Do not open this Test Booklet until you are asked to do so.

**Important Instructions :**

1. The Answer Sheet is inside this Test Booklet. When you are directed to open the Test Booklet, take out the Answer Sheet and fill in the particulars on OFFICE Copy carefully with **blue/black** ball point pen only.
2. The test is of **3 hours** duration and the Test Booklet contains **200** multiple-choice questions (four options with a single correct answer) from **Physics, Chemistry and Biology (Botany and Zoology)**. **50** questions in each subject are divided into **two Sections (A and B)** as per details given below :
  - (a) **Section A** shall consist of **35 (Thirty-five)** Questions in each subject (Question Nos – 1 to 35, 51 to 85, 101 to 135 and 151 to 185). All questions are compulsory.
  - (b) **Section B** shall consist of **15 (Fifteen)** questions in each subject (Question Nos – 36 to 50, 86 to 100, 136 to 150 and 186 to 200). In Section B, a candidate needs to **attempt any 10 (Ten)** questions out of **15 (Fifteen)** in each subject.

**Candidates are advised to read all 15 questions in each subject of Section B before they start attempting the question paper. In the event of a candidate attempting more than ten questions, the first ten questions answered by the candidate shall be evaluated.**
3. Each question carries **4** marks. For each correct response, the candidate will get **4** marks. For each incorrect response, **one** mark will be deducted from the total scores. **The maximum marks are 720.**
4. Use **Blue/Black Ball Point Pen only** for writing particulars on this page/markings responses on Answer Sheet.
5. Rough work is to be done in the space provided for this purpose in the Test Booklet only.
6. On completion of the test, the candidate **must hand over the Answer Sheet (ORIGINAL and OFFICE Copy) to the Invigilator** before leaving the Room/Hall. The candidates are allowed to take away this Test Booklet with them.
7. **The CODE for this Booklet is M1. Make sure that the CODE printed on the Original Copy of the Answer Sheet is the same as that on this Test Booklet.** In case of discrepancy, the candidate should immediately report the matter to the Invigilator for replacement of both the Test Booklet and the Answer Sheet.
8. The candidates should ensure that the Answer Sheet is not folded. Do not make any stray marks on the Answer Sheet. Do not write your Roll No. anywhere else except in the specified space in the Test Booklet/ Answer Sheet.
9. Use of white fluid for correction is **NOT** permissible on the Answer Sheet.
10. Each candidate must show on-demand his/her Admit Card to the Invigilator.
11. No candidate, without special permission of the centre Superintendent or Invigilator, would leave his/her seat.
12. The candidates should not leave the Examination Hall without handing over their Answer Sheet to the Invigilator on duty and sign (with time) the Attendance Sheet **twice**. **Cases, where a candidate has not signed the Attendance Sheet second time, will be deemed not to have handed over the Answer Sheet and dealt with as an Unfair Means case.**
13. Use of Electronic/Manual Calculator is prohibited.
14. The candidates are governed by all Rules and Regulations of the examination with regard to their conduct in the Examination Room/Hall. All cases of unfair means will be dealt with as per the Rules and Regulations of this examination.
15. **No part of the Test Booklet and Answer Sheet shall be detached under any circumstances.**
16. The candidates will write the Correct Test Booklet Code as given in the Test Booklet/Answer Sheet in the Attendance Sheet.

Name of the Candidate (in Capitals) : \_\_\_\_\_

Roll Number : in figures \_\_\_\_\_

: in words \_\_\_\_\_

Centre of Examination (in Capitals) : \_\_\_\_\_

Candidate's Signature : \_\_\_\_\_ Invigilator's Signature : \_\_\_\_\_

Facsimile signature stamp of  
Centre Superintendent : \_\_\_\_\_

## Section - A (Physics)

1. Two charged spherical conductors of radius  $R_1$  and  $R_2$  are connected by a wire. Then the ratio of surface charge densities of the spheres ( $\sigma_1/\sigma_2$ ) is :

- (1)  $\frac{R_1}{R_2}$   
 (2)  $\frac{R_2}{R_1}$   
 (3)  $\sqrt{\left(\frac{R_1}{R_2}\right)}$   
 (4)  $\frac{R_1^2}{R_2^2}$

2. The velocity of a small ball of mass  $M$  and density  $d$ , when dropped in a container filled with glycerine becomes constant after some time. If the density of glycerine is  $\frac{d}{2}$ , then the viscous force acting on the ball will be :

- (1)  $\frac{Mg}{2}$   
 (2)  $Mg$   
 (3)  $\frac{3}{2}Mg$   
 (4)  $2Mg$

3. An infinitely long straight conductor carries a current of 5 A as shown. An electron is moving with a speed of  $10^5$  m/s parallel to the conductor. The perpendicular distance between the electron and the conductor is 20 cm at an instant. Calculate the magnitude of the force experienced by the electron at that instant.

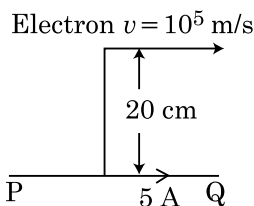

- (1)  $4 \times 10^{-20}$  N  
 (2)  $8\pi \times 10^{-20}$  N  
 (3)  $4\pi \times 10^{-20}$  N  
 (4)  $8 \times 10^{-20}$  N

4. A dipole is placed in an electric field as shown. In which direction will it move ?

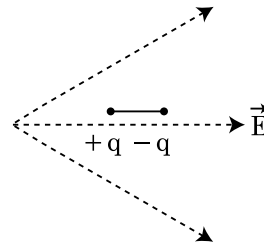

- (1) towards the left as its potential energy will increase.  
 (2) towards the right as its potential energy will decrease.  
 (3) towards the left as its potential energy will decrease.  
 (4) towards the right as its potential energy will increase.
5. A lens of large focal length and large aperture is best suited as an objective of an astronomical telescope since :
- (1) a large aperture contributes to the quality and visibility of the images.  
 (2) a large area of the objective ensures better light gathering power.  
 (3) a large aperture provides a better resolution.  
 (4) all of the above.
6. A screw gauge gives the following readings when used to measure the diameter of a wire  
 Main scale reading : 0 mm  
 Circular scale reading : 52 divisions  
 Given that 1 mm on main scale corresponds to 100 divisions on the circular scale. The diameter of the wire from the above data is :
- (1) 0.52 cm  
 (2) 0.026 cm  
 (3) 0.26 cm  
 (4) 0.052 cm

7. A nucleus with mass number 240 breaks into two fragments each of mass number 120, the binding energy per nucleon of unfragmented nuclei is 7.6 MeV while that of fragments is 8.5 MeV. The total gain in the Binding Energy in the process is :

- (1) 0.9 MeV  
 (2) 9.4 MeV  
 (3) 804 MeV  
 (4) 216 MeV

8. A small block slides down on a smooth inclined plane, starting from rest at time  $t=0$ . Let  $S_n$  be the distance travelled by the block in the interval  $t=n-1$  to  $t=n$ . Then, the ratio  $\frac{S_n}{S_{n+1}}$  is :

(1)  $\frac{2n-1}{2n}$

(2)  $\frac{2n-1}{2n+1}$

(3)  $\frac{2n+1}{2n-1}$

(4)  $\frac{2n}{2n-1}$

9. Find the value of the angle of emergence from the prism. Refractive index of the glass is  $\sqrt{3}$ .

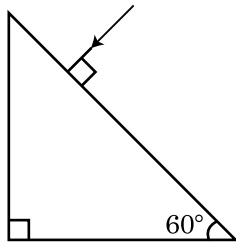

(1)  $60^\circ$

(2)  $30^\circ$

(3)  $45^\circ$

(4)  $90^\circ$

10. A spring is stretched by 5 cm by a force 10 N. The time period of the oscillations when a mass of 2 kg is suspended by it is :

(1) 0.0628 s

(2) 6.28 s

(3) 3.14 s

(4) 0.628 s

11. A convex lens 'A' of focal length 20 cm and a concave lens 'B' of focal length 5 cm are kept along the same axis with a distance 'd' between them. If a parallel beam of light falling on 'A' leaves 'B' as a parallel beam, then the distance 'd' in cm will be :

(1) 25

(2) 15

(3) 50

(4) 30

12. **Column - I** gives certain physical terms associated with flow of current through a metallic conductor. **Column - II** gives some mathematical relations involving electrical quantities. Match **Column - I** and **Column - II** with appropriate relations.

Column - I	Column - II
(A) Drift Velocity	(P) $\frac{m}{ne^2\rho}$
(B) Electrical Resistivity	(Q) $nev_d$
(C) Relaxation Period	(R) $\frac{eE}{m}\tau$
(D) Current Density	(S) $\frac{E}{J}$

(1) (A)-(R), (B)-(S), (C)-(P), (D)-(Q)

(2) (A)-(R), (B)-(S), (C)-(Q), (D)-(P)

(3) (A)-(R), (B)-(P), (C)-(S), (D)-(Q)

(4) (A)-(R), (B)-(Q), (C)-(S), (D)-(P)

13. The electron concentration in an n-type semiconductor is the same as hole concentration in a p-type semiconductor. An external field (electric) is applied across each of them. Compare the currents in them.

(1) current in n-type = current in p-type.

(2) current in p-type > current in n-type.

(3) current in n-type > current in p-type.

(4) No current will flow in p-type, current will only flow in n-type.

14. A radioactive nucleus  ${}^A_ZX$  undergoes spontaneous decay in the sequence

${}^A_ZX \rightarrow {}_{Z-1}B \rightarrow {}_{Z-3}C \rightarrow {}_{Z-2}D$ , where Z is the atomic number of element X. The possible decay particles in the sequence are :

(1)  $\alpha, \beta^-, \beta^+$

(2)  $\alpha, \beta^+, \beta^-$

(3)  $\beta^+, \alpha, \beta^-$

(4)  $\beta^-, \alpha, \beta^+$

15. Water falls from a height of 60 m at the rate of 15 kg/s to operate a turbine. The losses due to frictional force are 10% of the input energy. How much power is generated by the turbine ?

( $g = 10 \text{ m/s}^2$ )

(1) 10.2 kW

(2) 8.1 kW

(3) 12.3 kW

(4) 7.0 kW

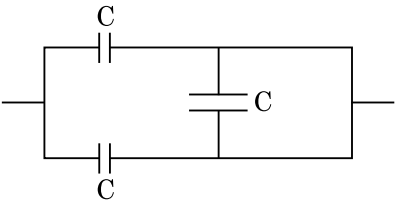
16. The number of photons per second on an average emitted by the source of monochromatic light of wavelength 600 nm, when it delivers the power of  $3.3 \times 10^{-3}$  watt will be : ( $h = 6.6 \times 10^{-34}$  Js)
- (1)  $10^{18}$
  - (2)  $10^{17}$
  - (3)  $10^{16}$
  - (4)  $10^{15}$
17. For a plane electromagnetic wave propagating in  $x$ -direction, which one of the following combination gives the correct possible directions for electric field (E) and magnetic field (B) respectively ?
- (1)  $\hat{j} + \hat{k}, \hat{j} + \hat{k}$
  - (2)  $-\hat{j} + \hat{k}, -\hat{j} - \hat{k}$
  - (3)  $\hat{j} + \hat{k}, -\hat{j} - \hat{k}$
  - (4)  $-\hat{j} + \hat{k}, -\hat{j} + \hat{k}$
18. The effective resistance of a parallel connection that consists of four wires of equal length, equal area of cross-section and same material is  $0.25 \Omega$ . What will be the effective resistance if they are connected in series ?
- (1)  $0.25 \Omega$
  - (2)  $0.5 \Omega$
  - (3)  $1 \Omega$
  - (4)  $4 \Omega$
19. In a potentiometer circuit a cell of EMF 1.5 V gives balance point at 36 cm length of wire. If another cell of EMF 2.5 V replaces the first cell, then at what length of the wire, the balance point occurs ?
- (1) 60 cm
  - (2) 21.6 cm
  - (3) 64 cm
  - (4) 62 cm
20. Polar molecules are the molecules :
- (1) having zero dipole moment.
  - (2) acquire a dipole moment only in the presence of electric field due to displacement of charges.
  - (3) acquire a dipole moment only when magnetic field is absent.
  - (4) having a permanent electric dipole moment.
21. A parallel plate capacitor has a uniform electric field ' $\vec{E}$ ' in the space between the plates. If the distance between the plates is 'd' and the area of each plate is 'A', the energy stored in the capacitor is : ( $\epsilon_0 =$  permittivity of free space)
- (1)  $\frac{1}{2} \epsilon_0 E^2$
  - (2)  $\epsilon_0 E A d$
  - (3)  $\frac{1}{2} \epsilon_0 E^2 A d$
  - (4)  $\frac{E^2 A d}{\epsilon_0}$
22. The equivalent capacitance of the combination shown in the figure is :
- 
- (1)  $3C$
  - (2)  $2C$
  - (3)  $C/2$
  - (4)  $3C/2$
23. Consider the following **statements (A) and (B)** and identify the **correct** answer.
- (A) A zener diode is connected in reverse bias, when used as a voltage regulator.
- (B) The potential barrier of p-n junction lies between 0.1 V to 0.3 V.
- (1) (A) and (B) both are correct.
  - (2) (A) and (B) both are incorrect.
  - (3) (A) is correct and (B) is incorrect.
  - (4) (A) is incorrect but (B) is correct.
24. A particle is released from height S from the surface of the Earth. At a certain height its kinetic energy is three times its potential energy. The height from the surface of earth and the speed of the particle at that instant are respectively :
- (1)  $\frac{S}{4}, \frac{3gS}{2}$
  - (2)  $\frac{S}{4}, \frac{\sqrt{3gS}}{2}$
  - (3)  $\frac{S}{2}, \frac{\sqrt{3gS}}{2}$
  - (4)  $\frac{S}{4}, \sqrt{\frac{3gS}{2}}$

25. If  $E$  and  $G$  respectively denote energy and gravitational constant, then  $\frac{E}{G}$  has the dimensions of :

- (1)  $[M^2] [L^{-1}] [T^0]$
- (2)  $[M] [L^{-1}] [T^{-1}]$
- (3)  $[M] [L^0] [T^0]$
- (4)  $[M^2] [L^{-2}] [T^{-1}]$

26. Match **Column - I** and **Column - II** and choose the **correct** match from the given choices.

<b>Column - I</b>	<b>Column - II</b>
(A) Root mean square speed of gas molecules	(P) $\frac{1}{3} nm \bar{v}^2$
(B) Pressure exerted by ideal gas	(Q) $\sqrt{\frac{3 RT}{M}}$
(C) Average kinetic energy of a molecule	(R) $\frac{5}{2} RT$
(D) Total internal energy of 1 mole of a diatomic gas	(S) $\frac{3}{2} k_B T$

- (1) (A) - (R), (B) - (P), (C) - (S), (D) - (Q)
- (2) (A) - (Q), (B) - (R), (C) - (S), (D) - (P)
- (3) (A) - (Q), (B) - (P), (C) - (S), (D) - (R)
- (4) (A) - (R), (B) - (Q), (C) - (P), (D) - (S)

27. A body is executing simple harmonic motion with frequency 'n', the frequency of its potential energy is :

- (1) n
- (2) 2n
- (3) 3n
- (4) 4n

28. A cup of coffee cools from  $90^\circ\text{C}$  to  $80^\circ\text{C}$  in  $t$  minutes, when the room temperature is  $20^\circ\text{C}$ . The time taken by a similar cup of coffee to cool from  $80^\circ\text{C}$  to  $60^\circ\text{C}$  at a room temperature same at  $20^\circ\text{C}$  is :

- (1)  $\frac{13}{10}t$
- (2)  $\frac{13}{5}t$
- (3)  $\frac{10}{13}t$
- (4)  $\frac{5}{13}t$

29. A capacitor of capacitance 'C', is connected across an ac source of voltage  $V$ , given by

$$V = V_0 \sin \omega t$$

The displacement current between the plates of the capacitor, would then be given by :

- (1)  $I_d = V_0 \omega C \cos \omega t$
- (2)  $I_d = \frac{V_0}{\omega C} \cos \omega t$
- (3)  $I_d = \frac{V_0}{\omega C} \sin \omega t$
- (4)  $I_d = V_0 \omega C \sin \omega t$

30. The half-life of a radioactive nuclide is 100 hours. The fraction of original activity that will remain after 150 hours would be :

- (1)  $1/2$
- (2)  $\frac{1}{2\sqrt{2}}$
- (3)  $\frac{2}{3}$
- (4)  $\frac{2}{3\sqrt{2}}$

31. An inductor of inductance  $L$ , a capacitor of capacitance  $C$  and a resistor of resistance 'R' are connected in series to an ac source of potential difference 'V' volts as shown in figure.

Potential difference across  $L$ ,  $C$  and  $R$  is 40 V, 10 V and 40 V, respectively. The amplitude of current flowing through LCR series circuit is  $10\sqrt{2}$  A. The impedance of the circuit is :

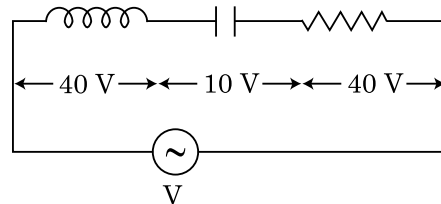

- (1)  $4\sqrt{2} \Omega$
- (2)  $5/\sqrt{2} \Omega$
- (3)  $4 \Omega$
- (4)  $5 \Omega$

32. A thick current carrying cable of radius 'R' carries current 'I' uniformly distributed across its cross-section. The variation of magnetic field B(r) due to the cable with the distance 'r' from the axis of the cable is represented by :

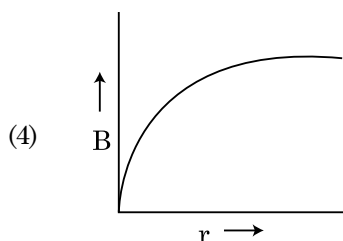
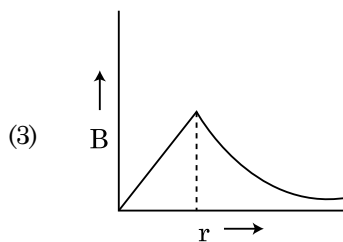
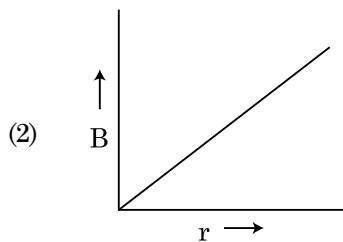
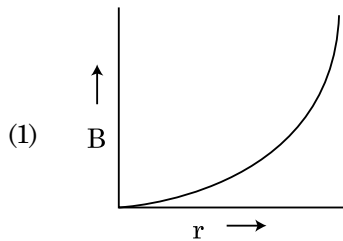

33. An electromagnetic wave of wavelength ' $\lambda$ ' is incident on a photosensitive surface of negligible work function. If 'm' mass is of photoelectron emitted from the surface has de-Broglie wavelength  $\lambda_d$ , then :

(1)  $\lambda = \left(\frac{2m}{hc}\right)\lambda_d^2$

(2)  $\lambda_d = \left(\frac{2mc}{h}\right)\lambda^2$

(3)  $\lambda = \left(\frac{2mc}{h}\right)\lambda_d^2$

(4)  $\lambda = \left(\frac{2h}{mc}\right)\lambda_d^2$

34. The escape velocity from the Earth's surface is  $v$ . The escape velocity from the surface of another planet having a radius, four times that of Earth and same mass density is :

- (1)  $v$   
 (2)  $2v$   
 (3)  $3v$   
 (4)  $4v$

35. If force [F], acceleration [A] and time [T] are chosen as the fundamental physical quantities. Find the dimensions of energy.

- (1) [F] [A] [T]  
 (2) [F] [A] [T<sup>2</sup>]  
 (3) [F] [A] [T<sup>-1</sup>]  
 (4) [F] [A<sup>-1</sup>] [T]

### Section - B (Physics)

36. Two conducting circular loops of radii  $R_1$  and  $R_2$  are placed in the same plane with their centres coinciding. If  $R_1 \gg R_2$ , the mutual inductance M between them will be directly proportional to :

(1)  $\frac{R_1}{R_2}$

(2)  $\frac{R_2}{R_1}$

(3)  $\frac{R_1^2}{R_2}$

(4)  $\frac{R_2^2}{R_1}$

37. A point object is placed at a distance of 60 cm from a convex lens of focal length 30 cm. If a plane mirror were put perpendicular to the principal axis of the lens and at a distance of 40 cm from it, the final image would be formed at a distance of :

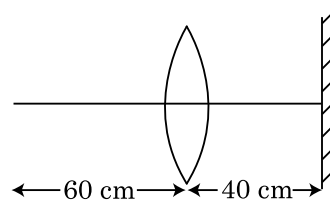

- (1) 20 cm from the lens, it would be a real image.  
 (2) 30 cm from the lens, it would be a real image.  
 (3) 30 cm from the plane mirror, it would be a virtual image.  
 (4) 20 cm from the plane mirror, it would be a virtual image.

38. Three resistors having resistances  $r_1$ ,  $r_2$  and  $r_3$  are connected as shown in the given circuit. The ratio  $\frac{i_3}{i_1}$  of currents in terms of resistances used in the circuit is :

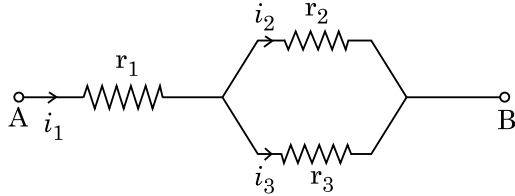

- (1)  $\frac{r_1}{r_2 + r_3}$   
 (2)  $\frac{r_2}{r_2 + r_3}$   
 (3)  $\frac{r_1}{r_1 + r_2}$   
 (4)  $\frac{r_2}{r_1 + r_3}$
39. For the given circuit, the input digital signals are applied at the terminals A, B and C. What would be the output at the terminal y ?

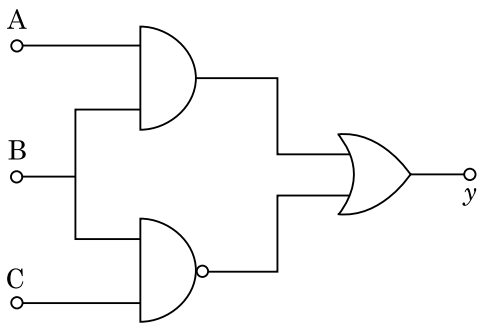
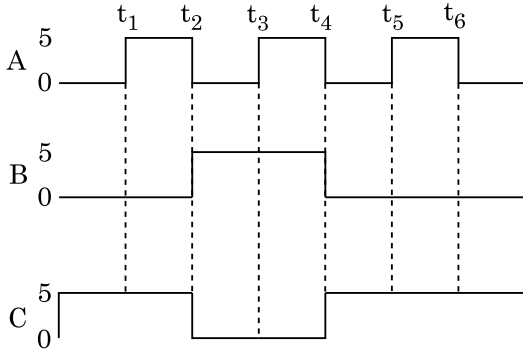

- (1)
- (2)
- (3)
- (4)

40. A series LCR circuit containing 5.0 H inductor, 80  $\mu$ F capacitor and 40  $\Omega$  resistor is connected to 230 V variable frequency ac source. The angular frequencies of the source at which power transferred to the circuit is half the power at the resonant angular frequency are likely to be :

- (1) 25 rad/s and 75 rad/s  
 (2) 50 rad/s and 25 rad/s  
 (3) 46 rad/s and 54 rad/s  
 (4) 42 rad/s and 58 rad/s

41. A car starts from rest and accelerates at 5  $\text{m/s}^2$ . At  $t = 4$  s, a ball is dropped out of a window by a person sitting in the car. What is the velocity and acceleration of the ball at  $t = 6$  s ? (Take  $g = 10 \text{ m/s}^2$ )

- (1) 20 m/s, 5  $\text{m/s}^2$   
 (2) 20 m/s, 0  
 (3)  $20\sqrt{2}$  m/s, 0  
 (4)  $20\sqrt{2}$  m/s, 10  $\text{m/s}^2$

42. A particle of mass 'm' is projected with a velocity  $v = kV_e$  ( $k < 1$ ) from the surface of the earth.

( $V_e$  = escape velocity)

The maximum height above the surface reached by the particle is :

- (1)  $R \left( \frac{k}{1-k} \right)^2$   
 (2)  $R \left( \frac{k}{1+k} \right)^2$   
 (3)  $\frac{R^2 k}{1+k}$   
 (4)  $\frac{Rk^2}{1-k^2}$

43. A particle moving in a circle of radius  $R$  with a uniform speed takes a time  $T$  to complete one revolution.

If this particle were projected with the same speed at an angle ' $\theta$ ' to the horizontal, the maximum height attained by it equals  $4R$ . The angle of projection,  $\theta$ , is then given by :

$$(1) \quad \theta = \cos^{-1} \left( \frac{gT^2}{\pi^2 R} \right)^{1/2}$$

$$(2) \quad \theta = \cos^{-1} \left( \frac{\pi^2 R}{gT^2} \right)^{1/2}$$

$$(3) \quad \theta = \sin^{-1} \left( \frac{\pi^2 R}{gT^2} \right)^{1/2}$$

$$(4) \quad \theta = \sin^{-1} \left( \frac{2gT^2}{\pi^2 R} \right)^{1/2}$$

44. In the product

$$\begin{aligned} \vec{F} &= q (\vec{v} \times \vec{B}) \\ &= q v \times (B \hat{i} + B \hat{j} + B_0 \hat{k}) \end{aligned}$$

For  $q=1$  and  $\vec{v} = 2\hat{i} + 4\hat{j} + 6\hat{k}$  and

$$\vec{F} = 4\hat{i} - 20\hat{j} + 12\hat{k}$$

What will be the complete expression for  $\vec{B}$  ?

$$(1) \quad -8\hat{i} - 8\hat{j} - 6\hat{k}$$

$$(2) \quad -6\hat{i} - 6\hat{j} - 8\hat{k}$$

$$(3) \quad 8\hat{i} + 8\hat{j} - 6\hat{k}$$

$$(4) \quad 6\hat{i} + 6\hat{j} - 8\hat{k}$$

45. A ball of mass  $0.15$  kg is dropped from a height  $10$  m, strikes the ground and rebounds to the same height. The magnitude of impulse imparted to the ball is ( $g = 10 \text{ m/s}^2$ ) nearly :

$$(1) \quad 0 \text{ kg m/s}$$

$$(2) \quad 4.2 \text{ kg m/s}$$

$$(3) \quad 2.1 \text{ kg m/s}$$

$$(4) \quad 1.4 \text{ kg m/s}$$

46. A uniform conducting wire of length  $12a$  and resistance ' $R$ ' is wound up as a current carrying coil in the shape of,

(i) an equilateral triangle of side ' $a$ '.

(ii) a square of side ' $a$ '.

The magnetic dipole moments of the coil in each case respectively are :

$$(1) \quad \sqrt{3} Ia^2 \text{ and } 3 Ia^2$$

$$(2) \quad 3 Ia^2 \text{ and } Ia^2$$

$$(3) \quad 3 Ia^2 \text{ and } 4 Ia^2$$

$$(4) \quad 4 Ia^2 \text{ and } 3 Ia^2$$

47. Twenty seven drops of same size are charged at  $220$  V each. They combine to form a bigger drop. Calculate the potential of the bigger drop.

$$(1) \quad 660 \text{ V}$$

$$(2) \quad 1320 \text{ V}$$

$$(3) \quad 1520 \text{ V}$$

$$(4) \quad 1980 \text{ V}$$



48. A uniform rod of length 200 cm and mass 500 g is balanced on a wedge placed at 40 cm mark. A mass of 2 kg is suspended from the rod at 20 cm and another unknown mass 'm' is suspended from the rod at 160 cm mark as shown in the figure. Find the value of 'm' such that the rod is in equilibrium. ( $g = 10 \text{ m/s}^2$ )

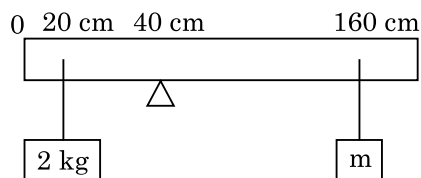

- (1)  $\frac{1}{2}$  kg  
 (2)  $\frac{1}{3}$  kg  
 (3)  $\frac{1}{6}$  kg  
 (4)  $\frac{1}{12}$  kg
49. From a circular ring of mass 'M' and radius 'R' an arc corresponding to a  $90^\circ$  sector is removed. The moment of inertia of the remaining part of the ring about an axis passing through the centre of the ring and perpendicular to the plane of the ring is 'K' times  $MR^2$ . Then the value of 'K' is :
- (1)  $\frac{3}{4}$   
 (2)  $\frac{7}{8}$   
 (3)  $\frac{1}{4}$   
 (4)  $\frac{1}{8}$
50. A step down transformer connected to an ac mains supply of 220 V is made to operate at 11 V, 44 W lamp. Ignoring power losses in the transformer, what is the current in the primary circuit ?

- (1) 0.2 A  
 (2) 0.4 A  
 (3) 2 A  
 (4) 4 A

### Section - A (Chemistry)

51. Dihedral angle of least stable conformer of ethane is :
- (1)  $120^\circ$   
 (2)  $180^\circ$   
 (3)  $60^\circ$   
 (4)  $0^\circ$
52. Noble gases are named because of their inertness towards reactivity. Identify an **incorrect** statement about them.
- (1) Noble gases are sparingly soluble in water.  
 (2) Noble gases have very high melting and boiling points.  
 (3) Noble gases have weak dispersion forces.  
 (4) Noble gases have large positive values of electron gain enthalpy.
53. The major product of the following chemical reaction is :
- $$\begin{array}{c} \text{CH}_3 \\ \diagdown \\ \text{CH} - \text{CH} = \text{CH}_2 \\ \diagup \\ \text{CH}_3 \end{array} + \text{HBr} \xrightarrow{(\text{C}_6\text{H}_5\text{CO})_2\text{O}_2} ?$$
- (1)  $\begin{array}{c} \text{CH}_3 \\ \diagdown \\ \text{CH} - \text{CH}_2 - \text{CH}_2 - \text{Br} \\ \diagup \\ \text{CH}_3 \end{array}$   
 (2)  $\begin{array}{c} \text{CH}_3 \\ \diagdown \\ \text{CH} - \text{CH}_2 - \text{CH}_2 - \text{O} - \text{COC}_6\text{H}_5 \\ \diagup \\ \text{CH}_3 \end{array}$   
 (3)  $\begin{array}{c} \text{CH}_3 \\ \diagdown \\ \text{CH} - \text{CH} - \text{CH}_3 \\ \diagup \quad | \\ \text{CH}_3 \quad \text{Br} \end{array}$   
 (4)  $\begin{array}{c} \text{CH}_3 \\ \diagdown \\ \text{CBr} - \text{CH}_2 - \text{CH}_3 \\ \diagup \\ \text{CH}_3 \end{array}$
54. A particular station of All India Radio, New Delhi, broadcasts on a frequency of 1,368 kHz (kilohertz). The wavelength of the electromagnetic radiation emitted by the transmitter is : [speed of light,  $c = 3.0 \times 10^8 \text{ ms}^{-1}$ ]
- (1) 219.3 m  
 (2) 219.2 m  
 (3) 2192 m  
 (4) 21.92 cm

55. The **incorrect** statement among the following is :

- (1) Actinoid contraction is greater for element to element than Lanthanoid contraction.
- (2) Most of the trivalent Lanthanoid ions are colorless in the solid state.
- (3) Lanthanoids are good conductors of heat and electricity.
- (4) Actinoids are highly reactive metals, especially when finely divided.

56. Right option for the number of tetrahedral and octahedral voids in hexagonal primitive unit cell are :

- (1) 8, 4
- (2) 6, 12
- (3) 2, 1
- (4) 12, 6

57. Identify the compound that will react with Hinsberg's reagent to give a solid which dissolves in alkali.

- (1)  $\text{CH}_3-\text{CH}_2-\ddot{\text{N}}\text{O}_2$
- (2)  $\text{CH}_3-\text{CH}_2-\ddot{\text{N}}\text{H}-\text{CH}_3$
- (3)  $\text{CH}_3-\text{CH}_2-\ddot{\text{N}}\text{H}_2$
- (4)  $\text{CH}_3-\text{CH}_2-\ddot{\text{N}}(\text{CH}_3)-\text{CH}_2-\text{CH}_3$

58. Which of the following reactions is the metal displacement reaction? Choose the right option.

- (1)  $2\text{KClO}_3 \xrightarrow{\Delta} 2\text{KCl} + 3\text{O}_2$
- (2)  $\text{Cr}_2\text{O}_3 + 2\text{Al} \xrightarrow{\Delta} \text{Al}_2\text{O}_3 + 2\text{Cr}$
- (3)  $\text{Fe} + 2\text{HCl} \rightarrow \text{FeCl}_2 + \text{H}_2 \uparrow$
- (4)  $2\text{Pb}(\text{NO}_3)_2 \rightarrow 2\text{PbO} + 4\text{NO}_2 + \text{O}_2 \uparrow$

59. Given below are two statements :

**Statement I :**

Aspirin and Paracetamol belong to the class of narcotic analgesics.

**Statement II :**

Morphine and Heroin are non-narcotic analgesics.

In the light of the above statements, choose the **correct** answer from the options given below.

- (1) Both **Statement I** and **Statement II** are true.
- (2) Both **Statement I** and **Statement II** are false.
- (3) **Statement I** is correct but **Statement II** is false.
- (4) **Statement I** is incorrect but **Statement II** is true.

60. What is the IUPAC name of the organic compound formed in the following chemical reaction ?

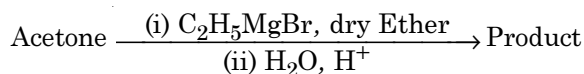

- (1) 2-methyl propan-2-ol
- (2) pentan-2-ol
- (3) pentan-3-ol
- (4) 2-methyl butan-2-ol

61. **Statement I :**

Acid strength increases in the order given as  $\text{HF} \ll \text{HCl} \ll \text{HBr} \ll \text{HI}$ .

**Statement II :**

As the size of the elements F, Cl, Br, I increases down the group, the bond strength of HF, HCl, HBr and HI decreases and so the acid strength increases.

In the light of the above statements, choose the **correct** answer from the options given below.

- (1) Both **Statement I** and **Statement II** are true.
- (2) Both **Statement I** and **Statement II** are false.
- (3) **Statement I** is correct but **Statement II** is false.
- (4) **Statement I** is incorrect but **Statement II** is true.

62. Which one among the following is the correct option for right relationship between  $C_P$  and  $C_V$  for one mole of ideal gas ?

- (1)  $C_P + C_V = R$
- (2)  $C_P - C_V = R$
- (3)  $C_P = RC_V$
- (4)  $C_V = RC_P$

63. Match **List - I** with **List - II**.

- | <b>List - I</b>    | <b>List - II</b>          |
|--------------------|---------------------------|
| (a) $\text{PCl}_5$ | (i) Square pyramidal      |
| (b) $\text{SF}_6$  | (ii) Trigonal planar      |
| (c) $\text{BrF}_5$ | (iii) Octahedral          |
| (d) $\text{BF}_3$  | (iv) Trigonal bipyramidal |

Choose the **correct** answer from the options given below.

- (1) (a)-(iv), (b)-(iii), (c)-(i), (d)-(ii)
- (2) (a)-(ii), (b)-(iii), (c)-(iv), (d)-(i)
- (3) (a)-(iii), (b)-(i), (c)-(iv), (d)-(ii)
- (4) (a)-(iv), (b)-(iii), (c)-(ii), (d)-(i)

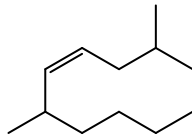
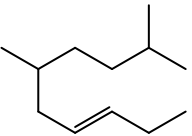
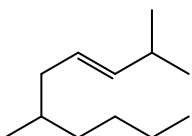
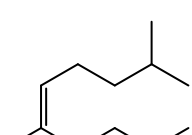
64. The following solutions were prepared by dissolving 10 g of glucose ( $C_6H_{12}O_6$ ) in 250 ml of water ( $P_1$ ), 10 g of urea ( $CH_4N_2O$ ) in 250 ml of water ( $P_2$ ) and 10 g of sucrose ( $C_{12}H_{22}O_{11}$ ) in 250 ml of water ( $P_3$ ). The right option for the decreasing order of osmotic pressure of these solutions is :
- (1)  $P_2 > P_1 > P_3$
  - (2)  $P_1 > P_2 > P_3$
  - (3)  $P_2 > P_3 > P_1$
  - (4)  $P_3 > P_1 > P_2$
65. Which one of the following methods can be used to obtain highly pure metal which is liquid at room temperature ?
- (1) Electrolysis
  - (2) Chromatography
  - (3) Distillation
  - (4) Zone refining
66. Tritium, a radioactive isotope of hydrogen, emits which of the following particles ?
- (1) Beta ( $\beta^-$ )
  - (2) Alpha ( $\alpha$ )
  - (3) Gamma ( $\gamma$ )
  - (4) Neutron (n)
67. The correct option for the number of body centred unit cells in all 14 types of Bravais lattice unit cells is :
- (1) 7
  - (2) 5
  - (3) 2
  - (4) 3
68. The major product formed in dehydrohalogenation reaction of 2-Bromo pentane is Pent-2-ene. This product formation is based on ?
- (1) Saytzeff's Rule
  - (2) Hund's Rule
  - (3) Hofmann Rule
  - (4) Huckel's Rule
69. The maximum temperature that can be achieved in blast furnace is :
- (1) upto 1200 K
  - (2) upto 2200 K
  - (3) upto 1900 K
  - (4) upto 5000 K
70. The molar conductance of NaCl, HCl and  $CH_3COONa$  at infinite dilution are 126.45, 426.16 and  $91.0 S cm^2 mol^{-1}$  respectively. The molar conductance of  $CH_3COOH$  at infinite dilution is. Choose the right option for your answer.
- (1)  $201.28 S cm^2 mol^{-1}$
  - (2)  $390.71 S cm^2 mol^{-1}$
  - (3)  $698.28 S cm^2 mol^{-1}$
  - (4)  $540.48 S cm^2 mol^{-1}$
71. Ethylene diaminetetraacetate (EDTA) ion is :
- (1) Hexadentate ligand with four "O" and two "N" donor atoms
  - (2) Unidentate ligand
  - (3) Bidentate ligand with two "N" donor atoms
  - (4) Tridentate ligand with three "N" donor atoms
72. The structures of beryllium chloride in solid state and vapour phase, are :
- (1) Chain and dimer, respectively
  - (2) Linear in both
  - (3) Dimer and Linear, respectively
  - (4) Chain in both
73. The correct structure of 2,6-Dimethyl-dec-4-ene is :
- (1) 
  - (2) 
  - (3) 
  - (4) 
74. The right option for the statement "Tyndall effect is exhibited by", is :
- (1) NaCl solution
  - (2) Glucose solution
  - (3) Starch solution
  - (4) Urea solution

75. Which one of the following polymers is prepared by addition polymerisation ?

- (1) Teflon
- (2) Nylon-66
- (3) Novolac
- (4) Dacron

76. The RBC deficiency is deficiency disease of :

- (1) Vitamin B<sub>12</sub>
- (2) Vitamin B<sub>6</sub>
- (3) Vitamin B<sub>1</sub>
- (4) Vitamin B<sub>2</sub>

77. The correct sequence of bond enthalpy of 'C-X' bond is :

- (1)  $\text{CH}_3 - \text{F} < \text{CH}_3 - \text{Cl} < \text{CH}_3 - \text{Br} < \text{CH}_3 - \text{I}$
- (2)  $\text{CH}_3 - \text{F} > \text{CH}_3 - \text{Cl} > \text{CH}_3 - \text{Br} > \text{CH}_3 - \text{I}$
- (3)  $\text{CH}_3 - \text{F} < \text{CH}_3 - \text{Cl} > \text{CH}_3 - \text{Br} > \text{CH}_3 - \text{I}$
- (4)  $\text{CH}_3 - \text{Cl} > \text{CH}_3 - \text{F} > \text{CH}_3 - \text{Br} > \text{CH}_3 - \text{I}$

78. An organic compound contains 78% (by wt.) carbon and remaining percentage of hydrogen. The right option for the empirical formula of this compound is : [Atomic wt. of C is 12, H is 1]

- (1) CH
- (2) CH<sub>2</sub>
- (3) CH<sub>3</sub>
- (4) CH<sub>4</sub>

79. Among the following alkaline earth metal halides, one which is covalent and soluble in organic solvents is :

- (1) Calcium chloride
- (2) Strontium chloride
- (3) Magnesium chloride
- (4) Beryllium chloride

80. BF<sub>3</sub> is planar and electron deficient compound. Hybridization and number of electrons around the central atom, respectively are :

- (1) sp<sup>3</sup> and 4
- (2) sp<sup>3</sup> and 6
- (3) sp<sup>2</sup> and 6
- (4) sp<sup>2</sup> and 8

81. The pK<sub>b</sub> of dimethylamine and pK<sub>a</sub> of acetic acid are 3.27 and 4.77 respectively at T (K). The correct option for the pH of dimethylammonium acetate solution is :

- (1) 8.50
- (2) 5.50
- (3) 7.75
- (4) 6.25

82. Choose the correct option for graphical representation of Boyle's law, which shows a graph of pressure vs. volume of a gas at different temperatures :

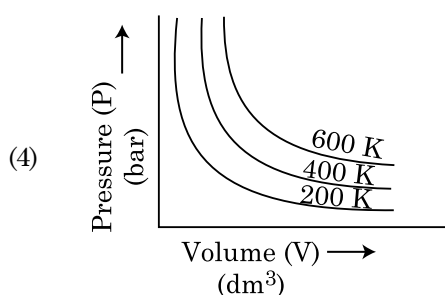
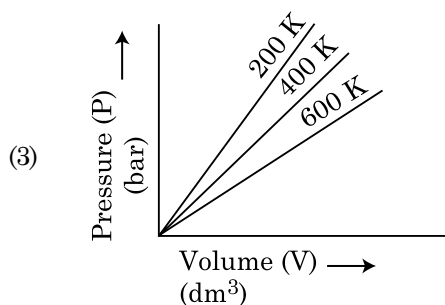
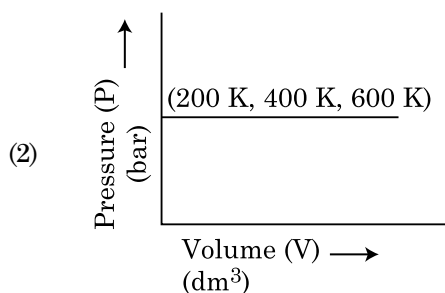
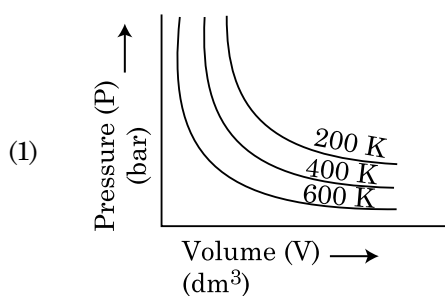

83. For a reaction  $A \rightarrow B$ , enthalpy of reaction is  $-4.2 \text{ kJ mol}^{-1}$  and enthalpy of activation is  $9.6 \text{ kJ mol}^{-1}$ . The correct potential energy profile for the reaction is shown in option.

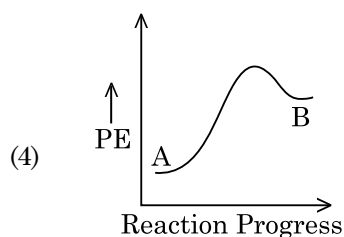
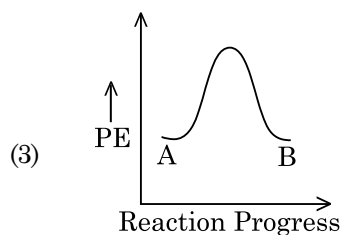
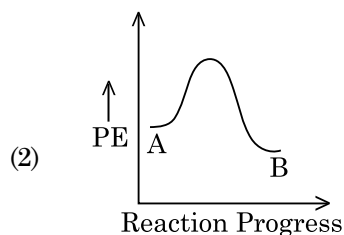
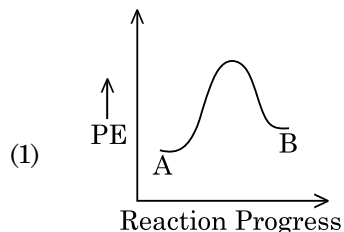

84. The compound which shows metamerism is :

- (1)  $\text{C}_5\text{H}_{12}$
- (2)  $\text{C}_3\text{H}_8\text{O}$
- (3)  $\text{C}_3\text{H}_6\text{O}$
- (4)  $\text{C}_4\text{H}_{10}\text{O}$

85. Zr ( $Z = 40$ ) and Hf ( $Z = 72$ ) have similar atomic and ionic radii because of :

- (1) belonging to same group
- (2) diagonal relationship
- (3) lanthanoid contraction
- (4) having similar chemical properties

### Section - B (Chemistry)

86. Match List - I with List - II.

List - I		List - II	
(a)	$[\text{Fe}(\text{CN})_6]^{3-}$	(i)	5.92 BM
(b)	$[\text{Fe}(\text{H}_2\text{O})_6]^{3+}$	(ii)	0 BM
(c)	$[\text{Fe}(\text{CN})_6]^{4-}$	(iii)	4.90 BM
(d)	$[\text{Fe}(\text{H}_2\text{O})_6]^{2+}$	(iv)	1.73 BM

Choose the **correct** answer from the options given below.

- (1) (a)-(iv), (b)-(ii), (c)-(i), (d)-(iii)
- (2) (a)-(ii), (b)-(iv), (c)-(iii), (d)-(i)
- (3) (a)-(i), (b)-(iii), (c)-(iv), (d)-(ii)
- (4) (a)-(iv), (b)-(i), (c)-(ii), (d)-(iii)

87. The reagent 'R' in the given sequence of chemical reaction is :

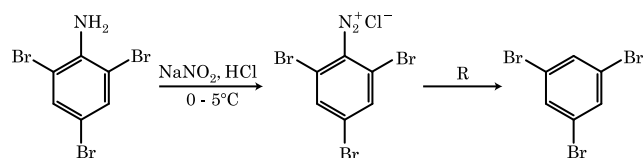

- (1)  $\text{H}_2\text{O}$
- (2)  $\text{CH}_3\text{CH}_2\text{OH}$
- (3) HI
- (4) CuCN/KCN

88. From the following pairs of ions which one is not an iso-electronic pair ?

- (1)  $\text{O}^{2-}$ ,  $\text{F}^-$
- (2)  $\text{Na}^+$ ,  $\text{Mg}^{2+}$
- (3)  $\text{Mn}^{2+}$ ,  $\text{Fe}^{3+}$
- (4)  $\text{Fe}^{2+}$ ,  $\text{Mn}^{2+}$

89. The slope of Arrhenius Plot  $\left( \ln k \text{ v/s } \frac{1}{T} \right)$  of first order reaction is  $-5 \times 10^3 \text{ K}$ . The value of  $E_a$  of the reaction is. Choose the correct option for your answer.

[Given  $R = 8.314 \text{ JK}^{-1}\text{mol}^{-1}$ ]

- (1)  $41.5 \text{ kJ mol}^{-1}$
- (2)  $83.0 \text{ kJ mol}^{-1}$
- (3)  $166 \text{ kJ mol}^{-1}$
- (4)  $-83 \text{ kJ mol}^{-1}$

90. For irreversible expansion of an ideal gas under isothermal condition, the correct option is :

- (1)  $\Delta U = 0$ ,  $\Delta S_{\text{total}} = 0$
- (2)  $\Delta U \neq 0$ ,  $\Delta S_{\text{total}} \neq 0$
- (3)  $\Delta U = 0$ ,  $\Delta S_{\text{total}} \neq 0$
- (4)  $\Delta U \neq 0$ ,  $\Delta S_{\text{total}} = 0$

91. In which one of the following arrangements the given sequence is not strictly according to the properties indicated against it ?

- (1)  $\text{HF} < \text{HCl} < \text{HBr} < \text{HI}$  : Increasing acidic strength
- (2)  $\text{H}_2\text{O} < \text{H}_2\text{S} < \text{H}_2\text{Se} < \text{H}_2\text{Te}$  : Increasing  $\text{pK}_a$  values
- (3)  $\text{NH}_3 < \text{PH}_3 < \text{AsH}_3 < \text{SbH}_3$  : Increasing acidic character
- (4)  $\text{CO}_2 < \text{SiO}_2 < \text{SnO}_2 < \text{PbO}_2$  : Increasing oxidizing power

92. The intermediate compound 'X' in the following chemical reaction is :

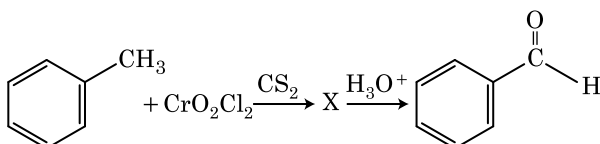

- (1)
- (2)
- (3)
- (4)

93. The correct option for the value of vapour pressure of a solution at  $45^\circ\text{C}$  with benzene to octane in molar ratio 3 : 2 is :

[At  $45^\circ\text{C}$  vapour pressure of benzene is 280 mm Hg and that of octane is 420 mm Hg. Assume Ideal gas]

- (1) 160 mm of Hg
- (2) 168 mm of Hg
- (3) 336 mm of Hg
- (4) 350 mm of Hg

94. The molar conductivity of 0.007 M acetic acid is  $20 \text{ S cm}^2 \text{ mol}^{-1}$ . What is the dissociation constant of acetic acid ? Choose the correct option.

$$\left[ \begin{array}{l} \Lambda_{\text{H}^+}^\circ = 350 \text{ S cm}^2 \text{ mol}^{-1} \\ \Lambda_{\text{CH}_3\text{COO}^-}^\circ = 50 \text{ S cm}^2 \text{ mol}^{-1} \end{array} \right]$$

- (1)  $1.75 \times 10^{-4} \text{ mol L}^{-1}$
- (2)  $2.50 \times 10^{-4} \text{ mol L}^{-1}$
- (3)  $1.75 \times 10^{-5} \text{ mol L}^{-1}$
- (4)  $2.50 \times 10^{-5} \text{ mol L}^{-1}$

95.  $\text{CH}_3\text{CH}_2\text{COO}^- \text{Na}^+ + \xrightarrow[\text{Heat}]{\text{NaOH, + ?}} \text{CH}_3\text{CH}_3 + \text{Na}_2\text{CO}_3$ .

Consider the above reaction and identify the missing reagent/chemical.

- (1)  $\text{B}_2\text{H}_6$
- (2) Red Phosphorus
- (3) CaO
- (4) DIBAL-H

96. Match List - I with List - II.

- | List - I   | List - II                          |
|--|------------------------------------|
| (a) $\xrightarrow[\text{CuCl}]{\text{CO, HCl, Anhyd. AlCl}_3}$   | (i) Hell-Volhard-Zelinsky reaction |
| (b) $\text{R}-\overset{\text{O}}{\parallel}{\text{C}}-\text{CH}_3 + \text{NaOX} \longrightarrow$         | (ii) Gattermann-Koch reaction      |
| (c) $\text{R}-\text{CH}_2-\text{OH} + \text{R}'\text{COOH} \xrightarrow{\text{Conc. H}_2\text{SO}_4}$    | (iii) Haloform reaction            |
| (d) $\text{R}-\text{CH}_2\text{COOH} \xrightarrow[\text{(ii) H}_2\text{O}]{\text{(i) X}_2/\text{Red P}}$ | (iv) Esterification                |

Choose the **correct** answer from the options given below.

- (1) (a)-(iv), (b)-(i), (c)-(ii), (d)-(iii)
- (2) (a)-(iii), (b)-(ii), (c)-(i), (d)-(iv)
- (3) (a)-(i), (b)-(iv), (c)-(iii), (d)-(ii)
- (4) (a)-(ii), (b)-(iii), (c)-(iv), (d)-(i)

97. The product formed in the following chemical reaction is :

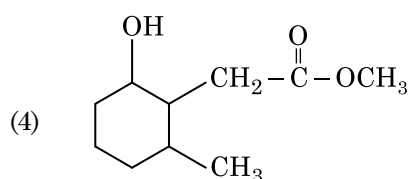
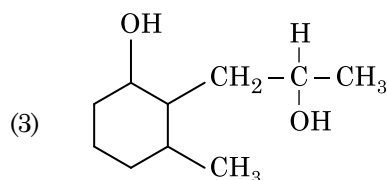
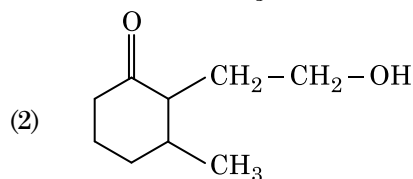
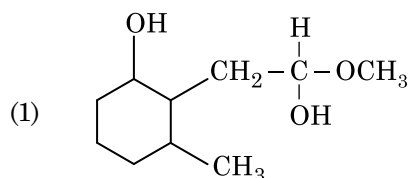
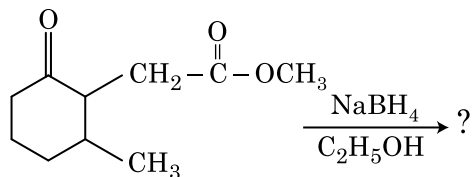

98. Which of the following molecules is non-polar in nature ?

- (1)  $\text{POCl}_3$   
 (2)  $\text{CH}_2\text{O}$   
 (3)  $\text{SbCl}_5$   
 (4)  $\text{NO}_2$

99. Match List - I with List - II.

- | List - I  | List - II                   |
|---|-----------------------------|
| (a) $2\text{SO}_2(\text{g}) + \text{O}_2(\text{g}) \rightarrow 2\text{SO}_3(\text{g})$                        | (i) Acid rain               |
| (b) $\text{HOCl}(\text{g}) \xrightarrow{h\nu} \overset{\cdot}{\text{O}}\text{H} + \overset{\cdot}{\text{Cl}}$ | (ii) Smog                   |
| (c) $\text{CaCO}_3 + \text{H}_2\text{SO}_4 \rightarrow \text{CaSO}_4 + \text{H}_2\text{O} + \text{CO}_2$      | (iii) Ozone depletion       |
| (d) $\text{NO}_2(\text{g}) \xrightarrow{h\nu} \text{NO}(\text{g}) + \text{O}(\text{g})$                       | (iv) Tropospheric pollution |

Choose the **correct** answer from the options given below.

- (1) (a)-(i), (b)-(ii), (c)-(iii), (d)-(iv)  
 (2) (a)-(ii), (b)-(iii), (c)-(iv), (d)-(i)  
 (3) (a)-(iv), (b)-(iii), (c)-(i), (d)-(ii)  
 (4) (a)-(iii), (b)-(ii), (c)-(iv), (d)-(i)

100. Choose the correct option for the total pressure (in atm.) in a mixture of 4 g  $\text{O}_2$  and 2 g  $\text{H}_2$  confined in a total volume of one litre at  $0^\circ\text{C}$  is :

[Given  $R = 0.082 \text{ L atm mol}^{-1}\text{K}^{-1}$ ,  $T = 273 \text{ K}$ ]

- (1) 2.518  
 (2) 2.602  
 (3) 25.18  
 (4) 26.02

### Section - A (Biology : Botany)

101. Which of the following plants is monoecious ?

- (1) *Carica papaya*  
 (2) *Chara*  
 (3) *Marchantia polymorpha*  
 (4) *Cycas circinalis*

102. A typical angiosperm embryo sac at maturity is :

- (1) 8-nucleate and 7-celled  
 (2) 7-nucleate and 8-celled  
 (3) 7-nucleate and 7-celled  
 (4) 8-nucleate and 8-celled

103. Gemmae are present in :

- (1) Mosses  
 (2) Pteridophytes  
 (3) Some Gymnosperms  
 (4) Some Liverworts

104. When the centromere is situated in the middle of two equal arms of chromosomes, the chromosome is referred as :

- (1) Metacentric  
 (2) Telocentric  
 (3) Sub-metacentric  
 (4) Acrocentric

105. Which of the following stages of meiosis involves division of centromere ?

- (1) Metaphase I  
 (2) Metaphase II  
 (3) Anaphase II  
 (4) Telophase II

106. The first stable product of  $\text{CO}_2$  fixation in sorghum is :

- (1) Pyruvic acid  
 (2) Oxaloacetic acid  
 (3) Succinic acid  
 (4) Phosphoglyceric acid

107. The factor that leads to Founder effect in a population is :
- (1) Natural selection
  - (2) Genetic recombination
  - (3) Mutation
  - (4) Genetic drift
108. Which of the following is an **incorrect** statement ?
- (1) Mature sieve tube elements possess a conspicuous nucleus and usual cytoplasmic organelles.
  - (2) Microbodies are present both in plant and animal cells.
  - (3) The perinuclear space forms a barrier between the materials present inside the nucleus and that of the cytoplasm.
  - (4) Nuclear pores act as passages for proteins and RNA molecules in both directions between nucleus and cytoplasm.
109. Amensalism can be represented as :
- (1) Species A (-) ; Species B (0)
  - (2) Species A (+) ; Species B (+)
  - (3) Species A (-) ; Species B (-)
  - (4) Species A (+) ; Species B (0)
110. The amount of nutrients, such as carbon, nitrogen, phosphorus and calcium present in the soil at any given time, is referred as :
- (1) Climax
  - (2) Climax community
  - (3) Standing state
  - (4) Standing crop
111. Which of the following algae contains mannitol as reserve food material ?
- (1) *Ectocarpus*
  - (2) *Gracilaria*
  - (3) *Volvox*
  - (4) *Ulothrix*
112. In spite of interspecific competition in nature, which mechanism the competing species might have evolved for their survival ?
- (1) Resource partitioning
  - (2) Competitive release
  - (3) Mutualism
  - (4) Predation
113. Genera like *Selaginella* and *Salvinia* produce two kinds of spores. Such plants are known as :
- (1) Homosorus
  - (2) Heterosorus
  - (3) Homosporous
  - (4) Heterosporous
114. The site of perception of light in plants during photoperiodism is :
- (1) Shoot apex
  - (2) Stem
  - (3) Axillary bud
  - (4) Leaf
115. Plants follow different pathways in response to environment or phases of life to form different kinds of structures. This ability is called :
- (1) Elasticity
  - (2) Flexibility
  - (3) Plasticity
  - (4) Maturity
116. Match List - I with List - II.
- | List - I |            | List - II |   |
|----------|------------|-----------|---|
| (a)      | Cristae    | (i)       | Primary constriction in chromosome              |
| (b)      | Thylakoids | (ii)      | Disc-shaped sacs in Golgi apparatus             |
| (c)      | Centromere | (iii)     | Infoldings in mitochondria                      |
| (d)      | Cisternae  | (iv)      | Flattened membranous sacs in stroma of plastids |
- Choose the **correct** answer from the options given below.
- |     | (a)   | (b)   | (c)   | (d)  |
|-----|-------|-------|-------|------|
| (1) | (iv)  | (iii) | (ii)  | (i)  |
| (2) | (i)   | (iv)  | (iii) | (ii) |
| (3) | (iii) | (iv)  | (i)   | (ii) |
| (4) | (ii)  | (iii) | (iv)  | (i)  |



117. Match List - I with List - II.

List - I		List - II	
(a)	Cohesion	(i)	More attraction in liquid phase
(b)	Adhesion	(ii)	Mutual attraction among water molecules
(c)	Surface tension	(iii)	Water loss in liquid phase
(d)	Guttation	(iv)	Attraction towards polar surfaces

Choose the **correct** answer from the options given below.

- |     | (a)   | (b)   | (c)  | (d)   |
|-----|-------|-------|------|-------|
| (1) | (ii)  | (iv)  | (i)  | (iii) |
| (2) | (iv)  | (iii) | (ii) | (i)   |
| (3) | (iii) | (i)   | (iv) | (ii)  |
| (4) | (ii)  | (i)   | (iv) | (iii) |

118. DNA strands on a gel stained with ethidium bromide when viewed under UV radiation, appear as :

- (1) Yellow bands
- (2) Bright orange bands
- (3) Dark red bands
- (4) Bright blue bands

119. The term used for transfer of pollen grains from anthers of one plant to stigma of a different plant which, during pollination, brings genetically different types of pollen grains to stigma, is :

- (1) Xenogamy
- (2) Geitonogamy
- (3) Chasmogamy
- (4) Cleistogamy

120. Which of the following algae produce Carrageen ?

- (1) Green algae
- (2) Brown algae
- (3) Red algae
- (4) Blue-green algae

121. Which of the following statements is **not** correct ?

- (1) Pyramid of biomass in sea is generally inverted.
- (2) Pyramid of biomass in sea is generally upright.
- (3) Pyramid of energy is always upright.
- (4) Pyramid of numbers in a grassland ecosystem is upright.

122. In the equation  $GPP - R = NPP$

R represents :

- (1) Radiant energy
- (2) Retardation factor
- (3) Environment factor
- (4) Respiration losses

123. Diadelphous stamens are found in :

- (1) China rose
- (2) Citrus
- (3) Pea
- (4) China rose and citrus

124. When gene targetting involving gene amplification is attempted in an individual's tissue to treat disease, it is known as :

- (1) Biopiracy
- (2) Gene therapy
- (3) Molecular diagnosis
- (4) Safety testing

125. Match List - I with List - II.

List - I		List - II	
(a)	Lenticels	(i)	Phellogen
(b)	Cork cambium	(ii)	Suberin deposition
(c)	Secondary cortex	(iii)	Exchange of gases
(d)	Cork	(iv)	Phelloderm

Choose the **correct** answer from the options given below.

- |     | (a)   | (b)   | (c)   | (d)   |
|-----|-------|-------|-------|-------|
| (1) | (iv)  | (i)   | (iii) | (ii)  |
| (2) | (iii) | (i)   | (iv)  | (ii)  |
| (3) | (ii)  | (iii) | (iv)  | (i)   |
| (4) | (iv)  | (ii)  | (i)   | (iii) |

126. The production of gametes by the parents, formation of zygotes, the  $F_1$  and  $F_2$  plants, can be understood from a diagram called :

- (1) Bullet square
- (2) Punch square
- (3) Punnett square
- (4) Net square

127. Which of the following is a **correct** sequence of steps in a PCR (Polymerase Chain Reaction) ?

- (1) Denaturation, Annealing, Extension
- (2) Denaturation, Extension, Annealing
- (3) Extension, Denaturation, Annealing
- (4) Annealing, Denaturation, Extension

128. Mutations in plant cells can be induced by :

- (1) Kinetin
- (2) Infrared rays
- (3) Gamma rays
- (4) Zeatin

129. Match List - I with List - II.

List - I		List - II	
(a)	Protoplast fusion	(i)	Totipotency
(b)	Plant tissue culture	(ii)	Pomato
(c)	Meristem culture	(iii)	Somaclones
(d)	Micropropagation	(iv)	Virus free plants

Choose the **correct** answer from the options given below.

- |     | (a)   | (b)   | (c)  | (d)   |
|-----|-------|-------|------|-------|
| (1) | (iii) | (iv)  | (ii) | (i)   |
| (2) | (ii)  | (i)   | (iv) | (iii) |
| (3) | (iii) | (iv)  | (i)  | (ii)  |
| (4) | (iv)  | (iii) | (ii) | (i)   |

130. During the purification process for recombinant DNA technology, addition of chilled ethanol precipitates out :

- (1) RNA
- (2) DNA
- (3) Histones
- (4) Polysaccharides

131. Complete the flow chart on central dogma.

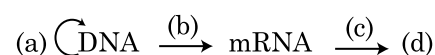

- (1) (a)-Replication; (b)-Transcription; (c)-Transduction; (d)-Protein
- (2) (a)-Translation; (b)-Replication; (c)-Transcription; (d)-Transduction
- (3) (a)-Replication; (b)-Transcription; (c)-Translation; (d)-Protein
- (4) (a)-Transduction; (b)-Translation; (c)-Replication; (d)-Protein

132. Which of the following is **not** an application of PCR (Polymerase Chain Reaction) ?

- (1) Molecular diagnosis
- (2) Gene amplification
- (3) Purification of isolated protein
- (4) Detection of gene mutation

133. The plant hormone used to destroy weeds in a field is :

- (1) IAA
- (2) NAA
- (3) 2, 4-D
- (4) IBA

134. Match List - I with List - II.

List - I		List - II	
(a)	Cells with active cell division capacity	(i)	Vascular tissues
(b)	Tissue having all cells similar in structure and function	(ii)	Meristematic tissue
(c)	Tissue having different types of cells	(iii)	Sclereids
(d)	Dead cells with highly thickened walls and narrow lumen	(iv)	Simple tissue

Select the **correct** answer from the options given below.

- |     | (a)   | (b)   | (c)   | (d)   |
|-----|-------|-------|-------|-------|
| (1) | (ii)  | (iv)  | (i)   | (iii) |
| (2) | (iv)  | (iii) | (ii)  | (i)   |
| (3) | (i)   | (ii)  | (iii) | (iv)  |
| (4) | (iii) | (ii)  | (iv)  | (i)   |

135. Which of the following are **not** secondary metabolites in plants ?

- (1) Morphine, codeine
- (2) Amino acids, glucose
- (3) Vinblastin, curcumin
- (4) Rubber, gums

### Section - B (Biology : Botany)

136. Which of the following statements is **incorrect** ?

- (1) During aerobic respiration, role of oxygen is limited to the terminal stage.
- (2) In ETC (Electron Transport Chain), one molecule of  $\text{NADH} + \text{H}^+$  gives rise to 2 ATP molecules, and one  $\text{FADH}_2$  gives rise to 3 ATP molecules.
- (3) ATP is synthesized through complex V.
- (4) Oxidation-reduction reactions produce proton gradient in respiration.

137. Match Column - I with Column - II.

Column - I		Column - II	
(a)	<i>Nitrococcus</i>	(i)	Denitrification
(b)	<i>Rhizobium</i>	(ii)	Conversion of ammonia to nitrite
(c)	<i>Thiobacillus</i>	(iii)	Conversion of nitrite to nitrate
(d)	<i>Nitrobacter</i>	(iv)	Conversion of atmospheric nitrogen to ammonia

Choose the **correct** answer from options given below.

- |     | (a)   | (b)   | (c)   | (d)   |
|-----|-------|-------|-------|-------|
| (1) | (ii)  | (iv)  | (i)   | (iii) |
| (2) | (i)   | (ii)  | (iii) | (iv)  |
| (3) | (iii) | (i)   | (iv)  | (ii)  |
| (4) | (iv)  | (iii) | (ii)  | (i)   |

138. Match Column - I with Column - II.

Column - I	Column - II
(a) $\% \overset{\curvearrowright}{\underset{\curvearrowleft}{\phi}} K_{(5)} C_{1+2+(2)} A_{(9)+1} \underline{G}_1$	(i) Brassicaceae
(b) $\oplus \overset{\curvearrowright}{\underset{\curvearrowleft}{\phi}} K_{(5)} \widehat{C}_{(5)} A_5 \underline{G}_2$	(ii) Liliaceae
(c) $\oplus \overset{\curvearrowright}{\underset{\curvearrowleft}{\phi}} P_{(3+3)} \widehat{A}_{3+3} \underline{G}_{(3)}$	(iii) Fabaceae
(d) $\oplus \overset{\curvearrowright}{\underset{\curvearrowleft}{\phi}} K_{2+2} C_4 A_{2-4} \underline{G}_{(2)}$	(iv) Solanaceae

Select the **correct** answer from the options given below.

- |     | (a)   | (b)   | (c)   | (d)   |
|-----|-------|-------|-------|-------|
| (1) | (iii) | (iv)  | (ii)  | (i)   |
| (2) | (i)   | (ii)  | (iii) | (iv)  |
| (3) | (ii)  | (iii) | (iv)  | (i)   |
| (4) | (iv)  | (ii)  | (i)   | (iii) |

139. Identify the **correct** statement.

- In capping, methyl guanosine triphosphate is added to the 3' end of hnRNA.
- RNA polymerase binds with Rho factor to terminate the process of transcription in bacteria.
- The coding strand in a transcription unit is copied to an mRNA.
- Split gene arrangement is characteristic of prokaryotes.

140. Which of the following statements is **correct** ?

- Fusion of two cells is called Karyogamy.
- Fusion of protoplasts between two motile non-motile gametes is called plasmogamy.
- Organisms that depend on living plants are called saprophytes.
- Some of the organisms can fix atmospheric nitrogen in specialized cells called sheath cells.

141. Select the **correct** pair.

- Large colorless empty cells in the epidermis of grass leaves - Subsidiary cells
- In dicot leaves, vascular bundles are surrounded by large thick-walled cells - Conjunctive tissue
- Cells of medullary rays that form part of cambial ring - Interfascicular cambium
- Loose parenchyma cells rupturing the epidermis and forming a lens-shaped opening in bark - Spongy parenchyma

142. DNA fingerprinting involves identifying differences in some specific regions in DNA sequence, called as :

- Satellite DNA
- Repetitive DNA
- Single nucleotides
- Polymorphic DNA

143. In some members of which of the following pairs of families, pollen grains retain their viability for months after release ?

- Poaceae ; Rosaceae
- Poaceae ; Leguminosae
- Poaceae ; Solanaceae
- Rosaceae ; Leguminosae

144. Which of the following statements is **incorrect** ?

- Both ATP and NADPH + H<sup>+</sup> are synthesized during non-cyclic photophosphorylation.
- Stroma lamellae have PS I only and lack NADP reductase.
- Grana lamellae have both PS I and PS II.
- Cyclic photophosphorylation involves both PS I and PS II.

145. What is the role of RNA polymerase III in the process of transcription in eukaryotes ?

- (1) Transcribes rRNAs (28S, 18S and 5.8S)
- (2) Transcribes tRNA, 5s rRNA and snRNA
- (3) Transcribes precursor of mRNA
- (4) Transcribes only snRNAs

146. In the exponential growth equation

$$N_t = N_0 e^{rt}, e \text{ represents :}$$

- (1) The base of number logarithms
- (2) The base of exponential logarithms
- (3) The base of natural logarithms
- (4) The base of geometric logarithms

147. Now a days it is possible to detect the mutated gene causing cancer by allowing radioactive probe to hybridise its complimentary DNA in a clone of cells, followed by its detection using autoradiography because :

- (1) mutated gene partially appears on a photographic film.
- (2) mutated gene completely and clearly appears on a photographic film.
- (3) mutated gene does not appear on a photographic film as the probe has no complimentarity with it.
- (4) mutated gene does not appear on photographic film as the probe has complimentarity with it.

148. Match List - I with List - II.

List - I		List - II	
(a)	Protein	(i)	C = C double bonds
(b)	Unsaturated fatty acid	(ii)	Phosphodiester bonds
(c)	Nucleic acid	(iii)	Glycosidic bonds
(d)	Polysaccharide	(iv)	Peptide bonds

Choose the **correct** answer from the options given below.

- |     | (a)  | (b)   | (c)   | (d)   |
|-----|------|-------|-------|-------|
| (1) | (iv) | (i)   | (ii)  | (iii) |
| (2) | (i)  | (iv)  | (iii) | (ii)  |
| (3) | (ii) | (i)   | (iv)  | (iii) |
| (4) | (iv) | (iii) | (i)   | (ii)  |

149. Match List - I with List - II.

List - I		List - II	
(a)	S phase	(i)	Proteins are synthesized
(b)	G <sub>2</sub> phase	(ii)	Inactive phase
(c)	Quiescent stage	(iii)	Interval between mitosis and initiation of DNA replication
(d)	G <sub>1</sub> phase	(iv)	DNA replication

Choose the **correct** answer from the options given below.

- |     | (a)   | (b)  | (c)   | (d)   |
|-----|-------|------|-------|-------|
| (1) | (iii) | (ii) | (i)   | (iv)  |
| (2) | (iv)  | (ii) | (iii) | (i)   |
| (3) | (iv)  | (i)  | (ii)  | (iii) |
| (4) | (ii)  | (iv) | (iii) | (i)   |

150. Plasmid pBR322 has PstI restriction enzyme site within gene *amp<sup>R</sup>* that confers ampicillin resistance. If this enzyme is used for inserting a gene for  $\beta$ -galactoside production and the recombinant plasmid is inserted in an *E.coli* strain

- (1) it will not be able to confer ampicillin resistance to the host cell.
- (2) the transformed cells will have the ability to resist ampicillin as well as produce  $\beta$ -galactoside.
- (3) it will lead to lysis of host cell.
- (4) it will be able to produce a novel protein with dual ability.

### Section - A (Biology : Zoology)

151. Identify the **incorrect** pair.

- (1) Alkaloids - Codeine
- (2) Toxin - Abrin
- (3) Lectins - Concanavalin A
- (4) Drugs - Ricin

152. The fruit fly has 8 chromosomes (2n) in each cell. During interphase of Mitosis if the number of chromosomes at G<sub>1</sub> phase is 8, what would be the number of chromosomes after S phase ?

- (1) 8
- (2) 16
- (3) 4
- (4) 32

153. Match List - I with List - II.

List - I		List - II	
(a)	Metamerism	(i)	Coelenterata
(b)	Canal system	(ii)	Ctenophora
(c)	Comb plates	(iii)	Annelida
(d)	Cnidoblasts	(iv)	Porifera

Choose the **correct** answer from the options given below.

- (a) (b) (c) (d)  
 (1) (iv) (iii) (i) (ii)  
 (2) (iii) (iv) (i) (ii)  
 (3) (iii) (iv) (ii) (i)  
 (4) (iv) (i) (ii) (iii)

154. Match List - I with List - II.

List - I		List - II	
(a)	Vaults	(i)	Entry of sperm through Cervix is blocked
(b)	IUDs	(ii)	Removal of Vas deferens
(c)	Vasectomy	(iii)	Phagocytosis of sperms within the Uterus
(d)	Tubectomy	(iv)	Removal of fallopian tube

Choose the **correct** answer from the options given below.

- (a) (b) (c) (d)  
 (1) (iv) (ii) (i) (iii)  
 (2) (i) (iii) (ii) (iv)  
 (3) (ii) (iv) (iii) (i)  
 (4) (iii) (i) (iv) (ii)

155. If Adenine makes 30% of the DNA molecule, what will be the percentage of Thymine, Guanine and Cytosine in it ?

- (1) T : 20 ; G : 30 ; C : 20  
 (2) T : 20 ; G : 20 ; C : 30  
 (3) T : 30 ; G : 20 ; C : 20  
 (4) T : 20 ; G : 25 ; C : 25

156. Which of the following RNAs is not required for the synthesis of protein ?

- (1) mRNA  
 (2) tRNA  
 (3) rRNA  
 (4) siRNA

157. Which one of the following is an example of Hormone releasing IUD ?

- (1) CuT  
 (2) LNG 20  
 (3) Cu 7  
 (4) Multiload 375

158. Succus entericus is referred to as :

- (1) Pancreatic juice  
 (2) Intestinal juice  
 (3) Gastric juice  
 (4) Chyme

159. Chronic auto immune disorder affecting neuro muscular junction leading to fatigue, weakening and paralysis of skeletal muscle is called as :

- (1) Arthritis  
 (2) Muscular dystrophy  
 (3) Myasthenia gravis  
 (4) Gout

160. With regard to insulin choose correct options.

- (a) C-peptide is not present in mature insulin.  
 (b) The insulin produced by rDNA technology has C-peptide.  
 (c) The pro-insulin has C-peptide.  
 (d) A-peptide and B-peptide of insulin are interconnected by disulphide bridges.

Choose the **correct** answer from the options given below.

- (1) (b) and (d) only  
 (2) (b) and (c) only  
 (3) (a), (c) and (d) only  
 (4) (a) and (d) only

161. Which one of the following belongs to the family Muscidae ?

- (1) Fire fly  
 (2) Grasshopper  
 (3) Cockroach  
 (4) House fly

162. Which is the "Only enzyme" that has "Capability" to catalyse Initiation, Elongation and Termination in the process of transcription in prokaryotes ?

- (1) DNA dependent DNA polymerase  
 (2) DNA dependent RNA polymerase  
 (3) DNA Ligase  
 (4) DNase

163. Receptors for sperm binding in mammals are present on :

- (1) Corona radiata  
 (2) Vitelline membrane  
 (3) Perivitelline space  
 (4) Zona pellucida

164. The centriole undergoes duplication during :

- (1) S-phase  
 (2) Prophase  
 (3) Metaphase  
 (4) G<sub>2</sub> phase

165. Which one of the following organisms bears hollow and pneumatic long bones ?

- (1) *Neophron*
- (2) *Hemidactylus*
- (3) *Macropus*
- (4) *Ornithorhynchus*

166. Erythropoietin hormone which stimulates R.B.C. formation is produced by :

- (1) Alpha cells of pancreas
- (2) The cells of rostral adenohypophysis
- (3) The cells of bone marrow
- (4) Juxtaglomerular cells of the kidney

167. Match the following :

List - I		List - II	
(a)	<i>Physalia</i>	(i)	Pearl oyster
(b)	<i>Limulus</i>	(ii)	Portuguese Man of War
(c)	<i>Ancylostoma</i>	(iii)	Living fossil
(d)	<i>Pinctada</i>	(iv)	Hookworm

Choose the **correct** answer from the options given below.

- |     | (a)  | (b)   | (c)   | (d)  |
|-----|------|-------|-------|------|
| (1) | (ii) | (iii) | (i)   | (iv) |
| (2) | (iv) | (i)   | (iii) | (ii) |
| (3) | (ii) | (iii) | (iv)  | (i)  |
| (4) | (i)  | (iv)  | (iii) | (ii) |

168. During the process of gene amplification using PCR, if very high temperature is not maintained in the beginning, then which of the following steps of PCR will be affected first ?

- (1) Annealing
- (2) Extension
- (3) Denaturation
- (4) Ligation

169. Which of the following statements wrongly represents the nature of smooth muscle ?

- (1) These muscle have no striations
- (2) They are involuntary muscles
- (3) Communication among the cells is performed by intercalated discs
- (4) These muscles are present in the wall of blood vessels

170. The organelles that are included in the endomembrane system are :

- (1) Endoplasmic reticulum, Mitochondria, Ribosomes and Lysosomes
- (2) Endoplasmic reticulum, Golgi complex, Lysosomes and Vacuoles
- (3) Golgi complex, Mitochondria, Ribosomes and Lysosomes
- (4) Golgi complex, Endoplasmic reticulum, Mitochondria and Lysosomes

171. Match List - I with List - II.

List - I		List - II	
(a)	<i>Aspergillus niger</i>	(i)	Acetic Acid
(b)	<i>Acetobacter aceti</i>	(ii)	Lactic Acid
(c)	<i>Clostridium butylicum</i>	(iii)	Citric Acid
(d)	<i>Lactobacillus</i>	(iv)	Butyric Acid

Choose the **correct** answer from the options given below.

- |     | (a)   | (b)   | (c)   | (d)   |
|-----|-------|-------|-------|-------|
| (1) | (iii) | (i)   | (iv)  | (ii)  |
| (2) | (i)   | (ii)  | (iii) | (iv)  |
| (3) | (ii)  | (iii) | (i)   | (iv)  |
| (4) | (iv)  | (ii)  | (i)   | (iii) |

172. For effective treatment of the disease, early diagnosis and understanding its pathophysiology is very important. Which of the following molecular diagnostic techniques is very useful for early detection ?

- (1) Western Blotting Technique
- (2) Southern Blotting Technique
- (3) ELISA Technique
- (4) Hybridization Technique

173. Which of the following characteristics is **incorrect** with respect to cockroach ?

- (1) A ring of gastric caeca is present at the junction of midgut and hind gut.
- (2) Hypopharynx lies within the cavity enclosed by the mouth parts.
- (3) In females, 7<sup>th</sup>-9<sup>th</sup> sterna together form a genital pouch.
- (4) 10<sup>th</sup> abdominal segment in both sexes, bears a pair of anal cerci.

174. Persons with 'AB' blood group are called as "Universal recipients". This is due to :

- (1) Absence of antigens A and B on the surface of RBCs
- (2) Absence of antigens A and B in plasma
- (3) Presence of antibodies, anti-A and anti-B, on RBCs
- (4) Absence of antibodies, anti-A and anti-B, in plasma

175. Dobson units are used to measure thickness of :
- (1) CFCs
  - (2) Stratosphere
  - (3) Ozone
  - (4) Troposphere
176. Read the following statements.
- (a) Metagenesis is observed in Helminths.
  - (b) Echinoderms are triploblastic and coelomate animals.
  - (c) Round worms have organ-system level of body organization.
  - (d) Comb plates present in ctenophores help in digestion.
  - (e) Water vascular system is characteristic of Echinoderms.
- Choose the **correct** answer from the options given below.
- (1) (c), (d) and (e) are correct
  - (2) (a), (b) and (c) are correct
  - (3) (a), (d) and (e) are correct
  - (4) (b), (c) and (e) are correct
177. In a cross between a male and female, both heterozygous for sickle cell anaemia gene, what percentage of the progeny will be diseased ?
- (1) 50%
  - (2) 75%
  - (3) 25%
  - (4) 100%
178. Which enzyme is responsible for the conversion of inactive fibrinogens to fibrins ?
- (1) Thrombin
  - (2) Renin
  - (3) Epinephrine
  - (4) Thrombokinase
179. Select the favourable conditions required for the formation of oxyhaemoglobin at the alveoli.
- (1) High  $pO_2$ , low  $pCO_2$ , less  $H^+$ , lower temperature
  - (2) Low  $pO_2$ , high  $pCO_2$ , more  $H^+$ , higher temperature
  - (3) High  $pO_2$ , high  $pCO_2$ , less  $H^+$ , higher temperature
  - (4) Low  $pO_2$ , low  $pCO_2$ , more  $H^+$ , higher temperature
180. Sphincter of oddi is present at :
- (1) Ileo-caecal junction
  - (2) Junction of hepato-pancreatic duct and duodenum
  - (3) Gastro-oesophageal junction
  - (4) Junction of jejunum and duodenum
181. Which stage of meiotic prophase shows terminalisation of chiasmata as its distinctive feature ?
- (1) Leptotene
  - (2) Zygotene
  - (3) Diakinesis
  - (4) Pachytene
182. Which of the following is **not** an objective of Biofortification in crops ?
- (1) Improve protein content
  - (2) Improve resistance to diseases
  - (3) Improve vitamin content
  - (4) Improve micronutrient and mineral content
183. The partial pressures (in mm Hg) of oxygen ( $O_2$ ) and carbon dioxide ( $CO_2$ ) at alveoli (the site of diffusion) are :
- (1)  $pO_2 = 104$  and  $pCO_2 = 40$
  - (2)  $pO_2 = 40$  and  $pCO_2 = 45$
  - (3)  $pO_2 = 95$  and  $pCO_2 = 40$
  - (4)  $pO_2 = 159$  and  $pCO_2 = 0.3$
184. Venereal diseases can spread through :
- (a) Using sterile needles
  - (b) Transfusion of blood from infected person
  - (c) Infected mother to foetus
  - (d) Kissing
  - (e) Inheritance
- Choose the **correct** answer from the options given below.
- (1) (a), (b) and (c) only
  - (2) (b), (c) and (d) only
  - (3) (b) and (c) only
  - (4) (a) and (c) only
185. A specific recognition sequence identified by endonucleases to make cuts at specific positions within the DNA is :
- (1) Degenerate primer sequence
  - (2) Okazaki sequences
  - (3) Palindromic Nucleotide sequences
  - (4) Poly(A) tail sequences

### Section - B (Biology : Zoology)

186. Which one of the following statements about Histones is **wrong** ?

- (1) Histones are organized to form a unit of 8 molecules.
- (2) The pH of histones is slightly acidic.
- (3) Histones are rich in amino acids - Lysine and Arginine.
- (4) Histones carry positive charge in the side chain.

187. During muscular contraction which of the following events occur ?

- (a) 'H' zone disappears
- (b) 'A' band widens
- (c) 'T' band reduces in width
- (d) Myosine hydrolyzes ATP, releasing the ADP and Pi
- (e) Z-lines attached to actins are pulled inwards

Choose the **correct** answer from the options given below.

- (1) (a), (c), (d), (e) only
- (2) (a), (b), (c), (d) only
- (3) (b), (c), (d), (e) only
- (4) (b), (d), (e), (a) only

188. Match List - I with List - II.

List - I		List - II	
(a)	Scapula	(i)	Cartilaginous joints
(b)	Cranium	(ii)	Flat bone
(c)	Sternum	(iii)	Fibrous joints
(d)	Vertebral column	(iv)	Triangular flat bone

Choose the **correct** answer from the options given below.

- |     | (a)  | (b)   | (c)   | (d)  |
|-----|------|-------|-------|------|
| (1) | (i)  | (iii) | (ii)  | (iv) |
| (2) | (ii) | (iii) | (iv)  | (i)  |
| (3) | (iv) | (ii)  | (iii) | (i)  |
| (4) | (iv) | (iii) | (ii)  | (i)  |

189. Which of these is not an important component of initiation of parturition in humans ?

- (1) Increase in estrogen and progesterone ratio
- (2) Synthesis of prostaglandins
- (3) Release of Oxytocin
- (4) Release of Prolactin

190. Assertion (A) :

A person goes to high altitude and experiences 'altitude sickness' with symptoms like breathing difficulty and heart palpitations.

Reason (R) :

Due to low atmospheric pressure at high altitude, the body does not get sufficient oxygen.

In the light of the above statements, choose the **correct** answer from the options given below.

- (1) Both (A) and (R) are true and (R) is the correct explanation of (A)
- (2) Both (A) and (R) are true but (R) is not the correct explanation of (A)
- (3) (A) is true but (R) is false
- (4) (A) is false but (R) is true

191. Following are the statements with reference to 'lipids'.

- (a) Lipids having only single bonds are called unsaturated fatty acids.
- (b) Lecithin is a phospholipid.
- (c) Trihydroxy propane is glycerol.
- (d) Palmitic acid has 20 carbon atoms including carboxyl carbon.
- (e) Arachidonic acid has 16 carbon atoms.

Choose the **correct** answer from the options given below.

- (1) (a) and (b) only
- (2) (c) and (d) only
- (3) (b) and (c) only
- (4) (b) and (e) only

192. The Adenosine deaminase deficiency results into :

- (1) Dysfunction of Immune system
- (2) Parkinson's disease
- (3) Digestive disorder
- (4) Addison's disease

193. Which of the following secretes the hormone, relaxin, during the later phase of pregnancy ?

- (1) Graafian follicle
- (2) Corpus luteum
- (3) Foetus
- (4) Uterus



194. Identify the types of cell junctions that help to stop the leakage of the substances across a tissue and facilitation of communication with neighbouring cells via rapid transfer of ions and molecules.

- (1) Gap junctions and Adhering junctions, respectively.
- (2) Tight junctions and Gap junctions, respectively.
- (3) Adhering junctions and Tight junctions, respectively.
- (4) Adhering junctions and Gap junctions, respectively.

195. Which of the following is **not** a step in Multiple Ovulation Embryo Transfer Technology (MOET) ?

- (1) Cow is administered hormone having LH like activity for super ovulation
- (2) Cow yields about 6-8 eggs at a time
- (3) Cow is fertilized by artificial insemination
- (4) Fertilized eggs are transferred to surrogate mothers at 8-32 cell stage

196. Match List - I with List - II.

List - I		List - II	
(a)	Filariasis	(i)	<i>Haemophilus influenzae</i>
(b)	Amoebiasis	(ii)	<i>Trichophyton</i>
(c)	Pneumonia	(iii)	<i>Wuchereria bancrofti</i>
(d)	Ringworm	(iv)	<i>Entamoeba histolytica</i>

Choose the **correct** answer from the options given below.

- |     |            |            |            |            |
|-----|------------|------------|------------|------------|
|     | <b>(a)</b> | <b>(b)</b> | <b>(c)</b> | <b>(d)</b> |
| (1) | (iv)       | (i)        | (iii)      | (ii)       |
| (2) | (iii)      | (iv)       | (i)        | (ii)       |
| (3) | (i)        | (ii)       | (iv)       | (iii)      |
| (4) | (ii)       | (iii)      | (i)        | (iv)       |

197. Match List - I with List - II.

List - I		List - II	
(a)	Allen's Rule	(i)	Kangaroo rat
(b)	Physiological adaptation	(ii)	Desert lizard
(c)	Behavioural adaptation	(iii)	Marine fish at depth
(d)	Biochemical adaptation	(iv)	Polar seal

Choose the **correct** answer from the options given below.

- |     |            |            |            |            |
|-----|------------|------------|------------|------------|
|     | <b>(a)</b> | <b>(b)</b> | <b>(c)</b> | <b>(d)</b> |
| (1) | (iv)       | (ii)       | (iii)      | (i)        |
| (2) | (iv)       | (i)        | (iii)      | (ii)       |
| (3) | (iv)       | (i)        | (ii)       | (iii)      |
| (4) | (iv)       | (iii)      | (ii)       | (i)        |

198. Match List - I with List - II.

List - I		List - II	
(a)	Adaptive radiation	(i)	Selection of resistant varieties due to excessive use of herbicides and pesticides
(b)	Convergent evolution	(ii)	Bones of forelimbs in Man and Whale
(c)	Divergent evolution	(iii)	Wings of Butterfly and Bird
(d)	Evolution by anthropogenic action	(iv)	Darwin Finches

Choose the **correct** answer from the options given below.

- |     |            |            |            |            |
|-----|------------|------------|------------|------------|
|     | <b>(a)</b> | <b>(b)</b> | <b>(c)</b> | <b>(d)</b> |
| (1) | (iv)       | (iii)      | (ii)       | (i)        |
| (2) | (iii)      | (ii)       | (i)        | (iv)       |
| (3) | (ii)       | (i)        | (iv)       | (iii)      |
| (4) | (i)        | (iv)       | (iii)      | (ii)       |

199. **Statement I :**

The codon 'AUG' codes for methionine and phenylalanine.

**Statement II :**

'AAA' and 'AAG' both codons code for the amino acid lysine.

In the light of the above statements, choose the **correct** answer from the options given below.

- (1) Both **Statement I** and **Statement II** are true
- (2) Both **Statement I** and **Statement II** are false
- (3) **Statement I** is correct but **Statement II** is false
- (4) **Statement I** is incorrect but **Statement II** is true

200. Following are the statements about prostomium of earthworm.

- (a) It serves as a covering for mouth.
- (b) It helps to open cracks in the soil into which it can crawl.
- (c) It is one of the sensory structures.
- (d) It is the first body segment.

Choose the **correct** answer from the options given below.

- (1) (a), (b) and (c) are correct
- (2) (a), (b) and (d) are correct
- (3) (a), (b), (c) and (d) are correct
- (4) (b) and (c) are correct

**M1**

**26**

**Space For Rough Work**

**Space For Rough Work**

**M1**

**28**

**Space For Rough Work**

Test Booklet Code

GAJAH

No. :

N1

This Booklet contains 28 pages.

Do not open this Test Booklet until you are asked to do so.

**Important Instructions :**

1. The Answer Sheet is inside this Test Booklet. When you are directed to open the Test Booklet, take out the Answer Sheet and fill in the particulars on OFFICE Copy carefully with **blue/black** ball point pen only.
2. The test is of **3 hours** duration and the Test Booklet contains **200** multiple-choice questions (four options with a single correct answer) from **Physics, Chemistry and Biology (Botany and Zoology)**. **50** questions in each subject are divided into **two Sections (A and B)** as per details given below :
  - (a) **Section A** shall consist of **35 (Thirty-five)** Questions in each subject (Question Nos – 1 to 35, 51 to 85, 101 to 135 and 151 to 185). All questions are compulsory.
  - (b) **Section B** shall consist of **15 (Fifteen)** questions in each subject (Question Nos – 36 to 50, 86 to 100, 136 to 150 and 186 to 200). In Section B, a candidate needs to **attempt any 10 (Ten)** questions out of **15 (Fifteen)** in each subject.

**Candidates are advised to read all 15 questions in each subject of Section B before they start attempting the question paper. In the event of a candidate attempting more than ten questions, the first ten questions answered by the candidate shall be evaluated.**
3. Each question carries **4** marks. For each correct response, the candidate will get **4** marks. For each incorrect response, **one** mark will be deducted from the total scores. **The maximum marks are 720.**
4. Use **Blue/Black Ball Point Pen only** for writing particulars on this page/markings responses on Answer Sheet.
5. Rough work is to be done in the space provided for this purpose in the Test Booklet only.
6. On completion of the test, the candidate **must hand over the Answer Sheet (ORIGINAL and OFFICE Copy) to the Invigilator** before leaving the Room/Hall. The candidates are allowed to take away this Test Booklet with them.
7. **The CODE for this Booklet is N1. Make sure that the CODE printed on the Original Copy of the Answer Sheet is the same as that on this Test Booklet.** In case of discrepancy, the candidate should immediately report the matter to the Invigilator for replacement of both the Test Booklet and the Answer Sheet.
8. The candidates should ensure that the Answer Sheet is not folded. Do not make any stray marks on the Answer Sheet. Do not write your Roll No. anywhere else except in the specified space in the Test Booklet/ Answer Sheet.
9. Use of white fluid for correction is **NOT** permissible on the Answer Sheet.
10. Each candidate must show on-demand his/her Admit Card to the Invigilator.
11. No candidate, without special permission of the centre Superintendent or Invigilator, would leave his/her seat.
12. The candidates should not leave the Examination Hall without handing over their Answer Sheet to the Invigilator on duty and sign (with time) the Attendance Sheet **twice**. **Cases, where a candidate has not signed the Attendance Sheet second time, will be deemed not to have handed over the Answer Sheet and dealt with as an Unfair Means case.**
13. Use of Electronic/Manual Calculator is prohibited.
14. The candidates are governed by all Rules and Regulations of the examination with regard to their conduct in the Examination Room/Hall. All cases of unfair means will be dealt with as per the Rules and Regulations of this examination.
15. **No part of the Test Booklet and Answer Sheet shall be detached under any circumstances.**
16. The candidates will write the Correct Test Booklet Code as given in the Test Booklet/Answer Sheet in the Attendance Sheet.

Name of the Candidate (in Capitals) : \_\_\_\_\_

Roll Number : in figures \_\_\_\_\_

: in words \_\_\_\_\_

Centre of Examination (in Capitals) : \_\_\_\_\_

Candidate's Signature : \_\_\_\_\_ Invigilator's Signature : \_\_\_\_\_

Facsimile signature stamp of  
Centre Superintendent : \_\_\_\_\_

## Section - A (Physics)

1. A lens of large focal length and large aperture is best suited as an objective of an astronomical telescope since :
- (1) a large aperture contributes to the quality and visibility of the images.
  - (2) a large area of the objective ensures better light gathering power.
  - (3) a large aperture provides a better resolution.
  - (4) all of the above.
2. A thick current carrying cable of radius 'R' carries current 'I' uniformly distributed across its cross-section. The variation of magnetic field  $B(r)$  due to the cable with the distance 'r' from the axis of the cable is represented by :

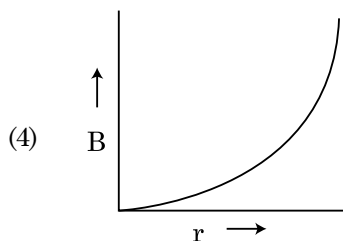
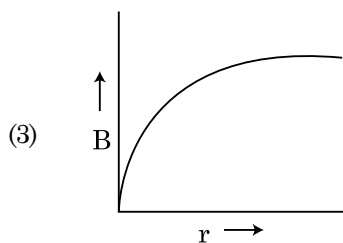
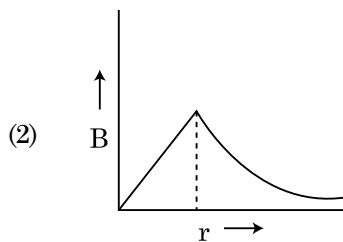
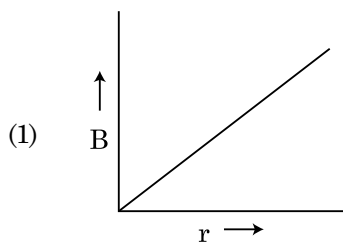

3. A spring is stretched by 5 cm by a force 10 N. The time period of the oscillations when a mass of 2 kg is suspended by it is :
- (1) 6.28 s
  - (2) 3.14 s
  - (3) 0.628 s
  - (4) 0.0628 s
4. Water falls from a height of 60 m at the rate of 15 kg/s to operate a turbine. The losses due to frictional force are 10% of the input energy. How much power is generated by the turbine ? ( $g = 10 \text{ m/s}^2$ )
- (1) 8.1 kW
  - (2) 12.3 kW
  - (3) 7.0 kW
  - (4) 10.2 kW
5. Polar molecules are the molecules :
- (1) acquire a dipole moment only in the presence of electric field due to displacement of charges.
  - (2) acquire a dipole moment only when magnetic field is absent.
  - (3) having a permanent electric dipole moment.
  - (4) having zero dipole moment.
6. Consider the following **statements (A) and (B)** and identify the **correct** answer.
- (A)** A zener diode is connected in reverse bias, when used as a voltage regulator.
- (B)** The potential barrier of p-n junction lies between 0.1 V to 0.3 V.
- (1) **(A)** and **(B)** both are incorrect.
  - (2) **(A)** is correct and **(B)** is incorrect.
  - (3) **(A)** is incorrect but **(B)** is correct.
  - (4) **(A)** and **(B)** both are correct.

7. An inductor of inductance  $L$ , a capacitor of capacitance  $C$  and a resistor of resistance ' $R$ ' are connected in series to an ac source of potential difference ' $V$ ' volts as shown in figure.

Potential difference across  $L$ ,  $C$  and  $R$  is  $40\text{ V}$ ,  $10\text{ V}$  and  $40\text{ V}$ , respectively. The amplitude of current flowing through LCR series circuit is  $10\sqrt{2}\text{ A}$ . The impedance of the circuit is :

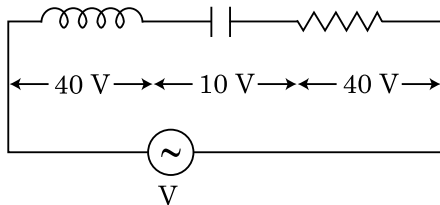

- (1)  $5/\sqrt{2}\ \Omega$   
 (2)  $4\ \Omega$   
 (3)  $5\ \Omega$   
 (4)  $4\sqrt{2}\ \Omega$
8. The escape velocity from the Earth's surface is  $v$ . The escape velocity from the surface of another planet having a radius, four times that of Earth and same mass density is :
- (1)  $2v$   
 (2)  $3v$   
 (3)  $4v$   
 (4)  $v$
9. A screw gauge gives the following readings when used to measure the diameter of a wire  
 Main scale reading :  $0\text{ mm}$   
 Circular scale reading :  $52$  divisions  
 Given that  $1\text{ mm}$  on main scale corresponds to  $100$  divisions on the circular scale. The diameter of the wire from the above data is :
- (1)  $0.026\text{ cm}$   
 (2)  $0.26\text{ cm}$   
 (3)  $0.052\text{ cm}$   
 (4)  $0.52\text{ cm}$
10. A cup of coffee cools from  $90^\circ\text{C}$  to  $80^\circ\text{C}$  in  $t$  minutes, when the room temperature is  $20^\circ\text{C}$ . The time taken by a similar cup of coffee to cool from  $80^\circ\text{C}$  to  $60^\circ\text{C}$  at a room temperature same at  $20^\circ\text{C}$  is :
- (1)  $\frac{13}{5}t$   
 (2)  $\frac{10}{13}t$   
 (3)  $\frac{5}{13}t$   
 (4)  $\frac{13}{10}t$

11. The half-life of a radioactive nuclide is  $100$  hours. The fraction of original activity that will remain after  $150$  hours would be :

- (1)  $\frac{1}{2\sqrt{2}}$   
 (2)  $\frac{2}{3}$   
 (3)  $\frac{2}{3\sqrt{2}}$   
 (4)  $1/2$

12. The number of photons per second on an average emitted by the source of monochromatic light of wavelength  $600\text{ nm}$ , when it delivers the power of  $3.3 \times 10^{-3}\text{ watt}$  will be : ( $h = 6.6 \times 10^{-34}\text{ Js}$ )

- (1)  $10^{17}$   
 (2)  $10^{16}$   
 (3)  $10^{15}$   
 (4)  $10^{18}$

13. A parallel plate capacitor has a uniform electric field ' $\vec{E}$ ' in the space between the plates. If the distance between the plates is ' $d$ ' and the area of each plate is ' $A$ ', the energy stored in the capacitor is : ( $\epsilon_0 =$  permittivity of free space)

- (1)  $\epsilon_0 E A d$   
 (2)  $\frac{1}{2} \epsilon_0 E^2 A d$   
 (3)  $\frac{E^2 A d}{\epsilon_0}$   
 (4)  $\frac{1}{2} \epsilon_0 E^2$

14. If force [ $F$ ], acceleration [ $A$ ] and time [ $T$ ] are chosen as the fundamental physical quantities. Find the dimensions of energy.

- (1)  $[F][A][T^2]$   
 (2)  $[F][A][T^{-1}]$   
 (3)  $[F][A^{-1}][T]$   
 (4)  $[F][A][T]$

15. The equivalent capacitance of the combination shown in the figure is :

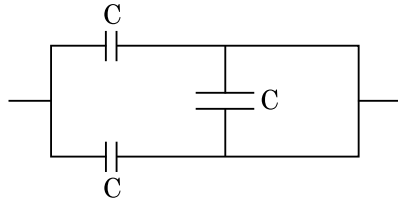

- (1)  $2C$   
 (2)  $C/2$   
 (3)  $3C/2$   
 (4)  $3C$
16. A capacitor of capacitance 'C', is connected across an ac source of voltage V, given by  $V = V_0 \sin \omega t$ . The displacement current between the plates of the capacitor, would then be given by :

- (1)  $I_d = \frac{V_0}{\omega C} \cos \omega t$   
 (2)  $I_d = \frac{V_0}{\omega C} \sin \omega t$   
 (3)  $I_d = V_0 \omega C \sin \omega t$   
 (4)  $I_d = V_0 \omega C \cos \omega t$

17. In a potentiometer circuit a cell of EMF 1.5 V gives balance point at 36 cm length of wire. If another cell of EMF 2.5 V replaces the first cell, then at what length of the wire, the balance point occurs ?
- (1) 21.6 cm  
 (2) 64 cm  
 (3) 62 cm  
 (4) 60 cm

18. **Column - I** gives certain physical terms associated with flow of current through a metallic conductor. **Column - II** gives some mathematical relations involving electrical quantities. Match **Column - I** and **Column - II** with appropriate relations.

Column - I	Column - II
(A) Drift Velocity	(P) $\frac{m}{ne^2 \rho}$
(B) Electrical Resistivity	(Q) $nev_d$
(C) Relaxation Period	(R) $\frac{eE}{m} \tau$
(D) Current Density	(S) $\frac{E}{J}$

(1) (A)-(R), (B)-(S), (C)-(Q), (D)-(P)  
 (2) (A)-(R), (B)-(P), (C)-(S), (D)-(Q)  
 (3) (A)-(R), (B)-(Q), (C)-(S), (D)-(P)  
 (4) (A)-(R), (B)-(S), (C)-(P), (D)-(Q)

19. A nucleus with mass number 240 breaks into two fragments each of mass number 120, the binding energy per nucleon of unfragmented nuclei is 7.6 MeV while that of fragments is 8.5 MeV. The total gain in the Binding Energy in the process is :

- (1) 9.4 MeV  
 (2) 804 MeV  
 (3) 216 MeV  
 (4) 0.9 MeV

20. Find the value of the angle of emergence from the prism. Refractive index of the glass is  $\sqrt{3}$ .

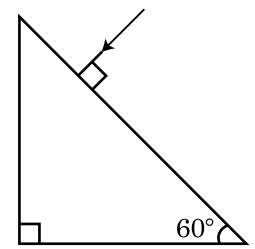

- (1) 30°  
 (2) 45°  
 (3) 90°  
 (4) 60°

21. If E and G respectively denote energy and gravitational constant, then  $\frac{E}{G}$  has the dimensions of :

- (1)  $[M] [L^{-1}] [T^{-1}]$   
 (2)  $[M] [L^0] [T^0]$   
 (3)  $[M^2] [L^{-2}] [T^{-1}]$   
 (4)  $[M^2] [L^{-1}] [T^0]$

22. A small block slides down on a smooth inclined plane, starting from rest at time  $t = 0$ . Let  $S_n$  be the distance travelled by the block in the interval  $t = n - 1$  to  $t = n$ . Then, the ratio  $\frac{S_n}{S_{n+1}}$  is :

- (1)  $\frac{2n-1}{2n+1}$   
 (2)  $\frac{2n+1}{2n-1}$   
 (3)  $\frac{2n}{2n-1}$   
 (4)  $\frac{2n-1}{2n}$



23. Match **Column - I** and **Column - II** and choose the **correct** match from the given choices.

<b>Column - I</b>	<b>Column - II</b>
(A) Root mean square speed of gas molecules	(P) $\frac{1}{3}nm\bar{v}^2$
(B) Pressure exerted by ideal gas	(Q) $\sqrt{\frac{3RT}{M}}$
(C) Average kinetic energy of a molecule	(R) $\frac{5}{2}RT$
(D) Total internal energy of 1 mole of a diatomic gas	(S) $\frac{3}{2}k_B T$

- (1) (A) - (Q), (B) - (R), (C) - (S), (D) - (P)  
 (2) (A) - (Q), (B) - (P), (C) - (S), (D) - (R)  
 (3) (A) - (R), (B) - (Q), (C) - (P), (D) - (S)  
 (4) (A) - (R), (B) - (P), (C) - (S), (D) - (Q)

24. A radioactive nucleus  ${}^A_ZX$  undergoes spontaneous decay in the sequence

${}^A_ZX \rightarrow {}_{Z-1}B \rightarrow {}_{Z-3}C \rightarrow {}_{Z-2}D$ , where Z is the atomic number of element X. The possible decay particles in the sequence are :

- (1)  $\alpha, \beta^+, \beta^-$   
 (2)  $\beta^+, \alpha, \beta^-$   
 (3)  $\beta^-, \alpha, \beta^+$   
 (4)  $\alpha, \beta^-, \beta^+$

25. The effective resistance of a parallel connection that consists of four wires of equal length, equal area of cross-section and same material is  $0.25 \Omega$ . What will be the effective resistance if they are connected in series ?

- (1)  $0.5 \Omega$   
 (2)  $1 \Omega$   
 (3)  $4 \Omega$   
 (4)  $0.25 \Omega$

26. A convex lens 'A' of focal length 20 cm and a concave lens 'B' of focal length 5 cm are kept along the same axis with a distance 'd' between them. If a parallel beam of light falling on 'A' leaves 'B' as a parallel beam, then the distance 'd' in cm will be :

- (1) 15  
 (2) 50  
 (3) 30  
 (4) 25

27. A particle is released from height S from the surface of the Earth. At a certain height its kinetic energy is three times its potential energy. The height from the surface of earth and the speed of the particle at that instant are respectively :

- (1)  $\frac{S}{4}, \frac{\sqrt{3gS}}{2}$   
 (2)  $\frac{S}{2}, \frac{\sqrt{3gS}}{2}$   
 (3)  $\frac{S}{4}, \sqrt{\frac{3gS}{2}}$   
 (4)  $\frac{S}{4}, \frac{3gS}{2}$

28. A dipole is placed in an electric field as shown. In which direction will it move ?

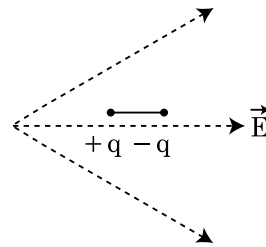

- (1) towards the right as its potential energy will decrease.  
 (2) towards the left as its potential energy will decrease.  
 (3) towards the right as its potential energy will increase.  
 (4) towards the left as its potential energy will increase.

29. Two charged spherical conductors of radius  $R_1$  and  $R_2$  are connected by a wire. Then the ratio of surface charge densities of the spheres ( $\sigma_1/\sigma_2$ ) is :

- (1)  $\frac{R_2}{R_1}$   
 (2)  $\sqrt{\frac{R_1}{R_2}}$   
 (3)  $\frac{R_1^2}{R_2^2}$   
 (4)  $\frac{R_1}{R_2}$

30. A body is executing simple harmonic motion with frequency 'n', the frequency of its potential energy is :

- (1)  $2n$
- (2)  $3n$
- (3)  $4n$
- (4)  $n$

31. The velocity of a small ball of mass M and density d, when dropped in a container filled with glycerine becomes constant after some time. If the density of glycerine is  $\frac{d}{2}$ , then the viscous force acting on the ball will be :

- (1) Mg
- (2)  $\frac{3}{2}Mg$
- (3) 2Mg
- (4)  $\frac{Mg}{2}$

32. An electromagnetic wave of wavelength ' $\lambda$ ' is incident on a photosensitive surface of negligible work function. If 'm' mass is of photoelectron emitted from the surface has de-Broglie wavelength  $\lambda_d$ , then :

- (1)  $\lambda_d = \left(\frac{2mc}{h}\right)\lambda^2$
- (2)  $\lambda = \left(\frac{2mc}{h}\right)\lambda_d^2$
- (3)  $\lambda = \left(\frac{2h}{mc}\right)\lambda_d^2$
- (4)  $\lambda = \left(\frac{2m}{hc}\right)\lambda_d^2$

33. For a plane electromagnetic wave propagating in x-direction, which one of the following combination gives the correct possible directions for electric field (E) and magnetic field (B) respectively ?

- (1)  $-\hat{j} + \hat{k}, -\hat{j} - \hat{k}$
- (2)  $\hat{j} + \hat{k}, -\hat{j} - \hat{k}$
- (3)  $-\hat{j} + \hat{k}, -\hat{j} + \hat{k}$
- (4)  $\hat{j} + \hat{k}, \hat{j} + \hat{k}$

34. An infinitely long straight conductor carries a current of 5 A as shown. An electron is moving with a speed of  $10^5$  m/s parallel to the conductor. The perpendicular distance between the electron and the conductor is 20 cm at an instant. Calculate the magnitude of the force experienced by the electron at that instant.

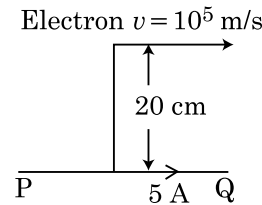

- (1)  $8\pi \times 10^{-20}$  N
- (2)  $4\pi \times 10^{-20}$  N
- (3)  $8 \times 10^{-20}$  N
- (4)  $4 \times 10^{-20}$  N

35. The electron concentration in an n-type semiconductor is the same as hole concentration in a p-type semiconductor. An external field (electric) is applied across each of them. Compare the currents in them.

- (1) current in p-type > current in n-type.
- (2) current in n-type > current in p-type.
- (3) No current will flow in p-type, current will only flow in n-type.
- (4) current in n-type = current in p-type.

### Section - B (Physics)

36. A particle moving in a circle of radius R with a uniform speed takes a time T to complete one revolution.

If this particle were projected with the same speed at an angle ' $\theta$ ' to the horizontal, the maximum height attained by it equals 4R. The angle of projection,  $\theta$ , is then given by :

- (1)  $\theta = \cos^{-1} \left( \frac{\pi^2 R}{gT^2} \right)^{1/2}$
- (2)  $\theta = \sin^{-1} \left( \frac{\pi^2 R}{gT^2} \right)^{1/2}$
- (3)  $\theta = \sin^{-1} \left( \frac{2gT^2}{\pi^2 R} \right)^{1/2}$
- (4)  $\theta = \cos^{-1} \left( \frac{gT^2}{\pi^2 R} \right)^{1/2}$

37. Three resistors having resistances  $r_1$ ,  $r_2$  and  $r_3$  are connected as shown in the given circuit. The ratio  $\frac{i_3}{i_1}$  of currents in terms of resistances used in the circuit is :

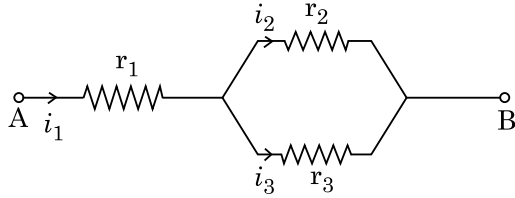

- (1)  $\frac{r_2}{r_2 + r_3}$   
 (2)  $\frac{r_1}{r_1 + r_2}$   
 (3)  $\frac{r_2}{r_1 + r_3}$   
 (4)  $\frac{r_1}{r_2 + r_3}$
38. A point object is placed at a distance of 60 cm from a convex lens of focal length 30 cm. If a plane mirror were put perpendicular to the principal axis of the lens and at a distance of 40 cm from it, the final image would be formed at a distance of :

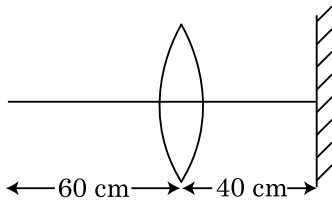

- (1) 30 cm from the lens, it would be a real image.  
 (2) 30 cm from the plane mirror, it would be a virtual image.  
 (3) 20 cm from the plane mirror, it would be a virtual image.  
 (4) 20 cm from the lens, it would be a real image.
39. A uniform conducting wire of length  $12a$  and resistance 'R' is wound up as a current carrying coil in the shape of,

- (i) an equilateral triangle of side 'a'.  
 (ii) a square of side 'a'.

The magnetic dipole moments of the coil in each case respectively are :

- (1)  $3 Ia^2$  and  $Ia^2$   
 (2)  $3 Ia^2$  and  $4 Ia^2$   
 (3)  $4 Ia^2$  and  $3 Ia^2$   
 (4)  $\sqrt{3} Ia^2$  and  $3 Ia^2$

40. For the given circuit, the input digital signals are applied at the terminals A, B and C. What would be the output at the terminal y ?

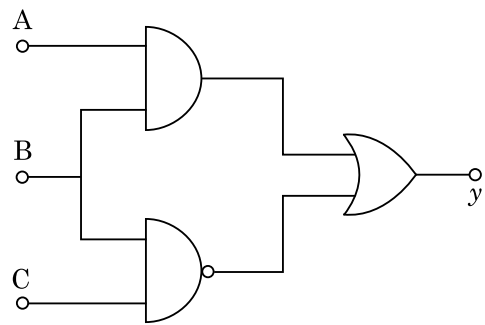
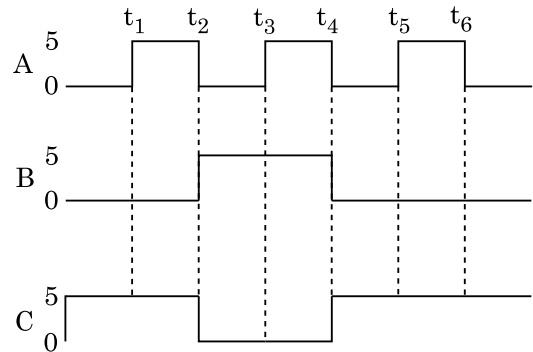

- (1)  $y$  is high (5V) from  $t_1$  to  $t_2$  and  $t_5$  to  $t_6$ , and low (0V) otherwise.  
 (2)  $y$  is high (5V) from  $t_2$  to  $t_4$ , and low (0V) otherwise.  
 (3)  $y$  is high (5V) from  $t_1$  to  $t_6$ .  
 (4)  $y$  is high (5V) from  $t_2$  to  $t_4$ , and low (0V) otherwise.

41. A ball of mass 0.15 kg is dropped from a height 10 m, strikes the ground and rebounds to the same height. The magnitude of impulse imparted to the ball is ( $g = 10 \text{ m/s}^2$ ) nearly :

- (1) 4.2 kg m/s  
 (2) 2.1 kg m/s  
 (3) 1.4 kg m/s  
 (4) 0 kg m/s

42. A step down transformer connected to an ac mains supply of 220 V is made to operate at 11 V, 44 W lamp. Ignoring power losses in the transformer, what is the current in the primary circuit ?

- (1) 0.4 A  
 (2) 2 A  
 (3) 4 A  
 (4) 0.2 A

43. A series LCR circuit containing 5.0 H inductor, 80  $\mu$ F capacitor and 40  $\Omega$  resistor is connected to 230 V variable frequency ac source. The angular frequencies of the source at which power transferred to the circuit is half the power at the resonant angular frequency are likely to be :
- (1) 50 rad/s and 25 rad/s
  - (2) 46 rad/s and 54 rad/s
  - (3) 42 rad/s and 58 rad/s
  - (4) 25 rad/s and 75 rad/s

44. A uniform rod of length 200 cm and mass 500 g is balanced on a wedge placed at 40 cm mark. A mass of 2 kg is suspended from the rod at 20 cm and another unknown mass 'm' is suspended from the rod at 160 cm mark as shown in the figure. Find the value of 'm' such that the rod is in equilibrium. ( $g = 10 \text{ m/s}^2$ )

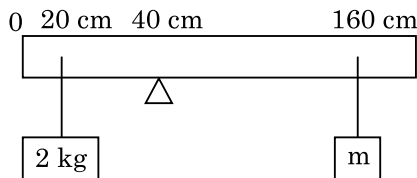

- (1)  $\frac{1}{3}$  kg
  - (2)  $\frac{1}{6}$  kg
  - (3)  $\frac{1}{12}$  kg
  - (4)  $\frac{1}{2}$  kg
45. A car starts from rest and accelerates at 5  $\text{m/s}^2$ . At  $t = 4$  s, a ball is dropped out of a window by a person sitting in the car. What is the velocity and acceleration of the ball at  $t = 6$  s ? (Take  $g = 10 \text{ m/s}^2$ )
- (1) 20 m/s, 0
  - (2)  $20\sqrt{2}$  m/s, 0
  - (3)  $20\sqrt{2}$  m/s, 10  $\text{m/s}^2$
  - (4) 20 m/s, 5  $\text{m/s}^2$
46. Twenty seven drops of same size are charged at 220 V each. They combine to form a bigger drop. Calculate the potential of the bigger drop.
- (1) 1320 V
  - (2) 1520 V
  - (3) 1980 V
  - (4) 660 V

47. Two conducting circular loops of radii  $R_1$  and  $R_2$  are placed in the same plane with their centres coinciding. If  $R_1 \gg R_2$ , the mutual inductance M between them will be directly proportional to :

- (1)  $\frac{R_2}{R_1}$
- (2)  $\frac{R_1^2}{R_2}$
- (3)  $\frac{R_2^2}{R_1}$
- (4)  $\frac{R_1}{R_2}$

48. A particle of mass 'm' is projected with a velocity  $v = kV_e$  ( $k < 1$ ) from the surface of the earth.

( $V_e =$  escape velocity)

The maximum height above the surface reached by the particle is :

- (1)  $R \left( \frac{k}{1+k} \right)^2$
- (2)  $\frac{R^2 k}{1+k}$
- (3)  $\frac{Rk^2}{1-k^2}$
- (4)  $R \left( \frac{k}{1-k} \right)^2$

49. In the product

$$\vec{F} = q \left( \vec{v} \times \vec{B} \right)$$

$$= q \vec{v} \times \left( B \hat{i} + B \hat{j} + B_0 \hat{k} \right)$$

For  $q = 1$  and  $\vec{v} = 2 \hat{i} + 4 \hat{j} + 6 \hat{k}$  and

$$\vec{F} = 4 \hat{i} - 20 \hat{j} + 12 \hat{k}$$

What will be the complete expression for  $\vec{B}$  ?

- (1)  $-6 \hat{i} - 6 \hat{j} - 8 \hat{k}$
- (2)  $8 \hat{i} + 8 \hat{j} - 6 \hat{k}$
- (3)  $6 \hat{i} + 6 \hat{j} - 8 \hat{k}$
- (4)  $-8 \hat{i} - 8 \hat{j} - 6 \hat{k}$

50. From a circular ring of mass 'M' and radius 'R' an arc corresponding to a  $90^\circ$  sector is removed. The moment of inertia of the remaining part of the ring about an axis passing through the centre of the ring and perpendicular to the plane of the ring is 'K' times  $MR^2$ . Then the value of 'K' is :

- (1)  $\frac{7}{8}$   
 (2)  $\frac{1}{4}$   
 (3)  $\frac{1}{8}$   
 (4)  $\frac{3}{4}$

### Section - A (Chemistry)

51. Choose the correct option for graphical representation of Boyle's law, which shows a graph of pressure vs. volume of a gas at different temperatures :

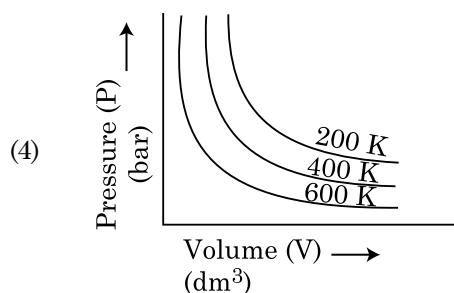
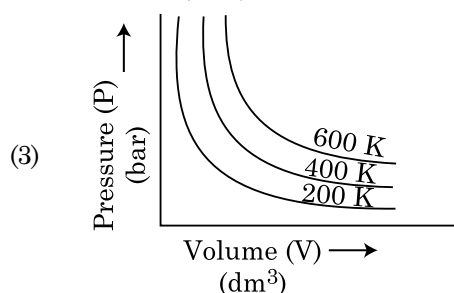
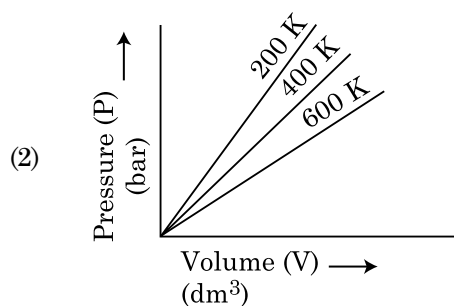
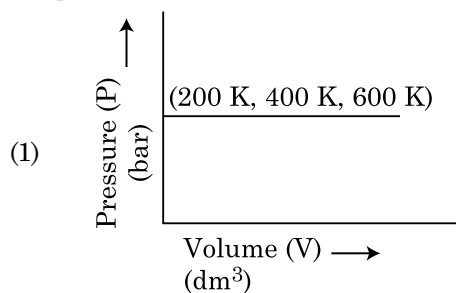

52. **Statement I :**

Acid strength increases in the order given as  $HF \ll HCl \ll HBr \ll HI$ .

**Statement II :**

As the size of the elements F, Cl, Br, I increases down the group, the bond strength of HF, HCl, HBr and HI decreases and so the acid strength increases.

In the light of the above statements, choose the **correct** answer from the options given below.

- (1) Both **Statement I** and **Statement II** are false.  
 (2) **Statement I** is correct but **Statement II** is false.  
 (3) **Statement I** is incorrect but **Statement II** is true.  
 (4) Both **Statement I** and **Statement II** are true.

53. Tritium, a radioactive isotope of hydrogen, emits which of the following particles ?

- (1) Alpha ( $\alpha$ )  
 (2) Gamma ( $\gamma$ )  
 (3) Neutron ( $n$ )  
 (4) Beta ( $\beta^-$ )

54. The maximum temperature that can be achieved in blast furnace is :

- (1) upto 2200 K  
 (2) upto 1900 K  
 (3) upto 5000 K  
 (4) upto 1200 K

55. Noble gases are named because of their inertness towards reactivity. Identify an **incorrect** statement about them.

- (1) Noble gases have very high melting and boiling points.  
 (2) Noble gases have weak dispersion forces.  
 (3) Noble gases have large positive values of electron gain enthalpy.  
 (4) Noble gases are sparingly soluble in water.

56. Identify the compound that will react with Hinsberg's reagent to give a solid which dissolves in alkali.

- (1)
- (2)
- (3)
- (4)

57. Among the following alkaline earth metal halides, one which is covalent and soluble in organic solvents is :

- (1) Strontium chloride  
 (2) Magnesium chloride  
 (3) Beryllium chloride  
 (4) Calcium chloride

58. What is the IUPAC name of the organic compound formed in the following chemical reaction ?

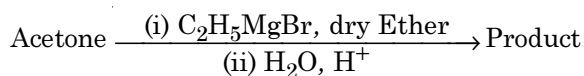

- (1) pentan-2-ol  
 (2) pentan-3-ol  
 (3) 2-methyl butan-2-ol  
 (4) 2-methyl propan-2-ol

59.  $\text{BF}_3$  is planar and electron deficient compound. Hybridization and number of electrons around the central atom, respectively are :

- (1)  $sp^3$  and 6  
 (2)  $sp^2$  and 6  
 (3)  $sp^2$  and 8  
 (4)  $sp^3$  and 4

60. The structures of beryllium chloride in solid state and vapour phase, are :

- (1) Linear in both  
 (2) Dimer and Linear, respectively  
 (3) Chain in both  
 (4) Chain and dimer, respectively

61. The RBC deficiency is deficiency disease of :

- (1) Vitamin  $\text{B}_6$   
 (2) Vitamin  $\text{B}_1$   
 (3) Vitamin  $\text{B}_2$   
 (4) Vitamin  $\text{B}_{12}$

62. The correct option for the number of body centred unit cells in all 14 types of Bravais lattice unit cells is :

- (1) 5  
 (2) 2  
 (3) 3  
 (4) 7

63. The molar conductance of  $\text{NaCl}$ ,  $\text{HCl}$  and  $\text{CH}_3\text{COONa}$  at infinite dilution are 126.45, 426.16 and  $91.0 \text{ S cm}^2 \text{ mol}^{-1}$  respectively. The molar conductance of  $\text{CH}_3\text{COOH}$  at infinite dilution is. Choose the right option for your answer.

- (1)  $390.71 \text{ S cm}^2 \text{ mol}^{-1}$   
 (2)  $698.28 \text{ S cm}^2 \text{ mol}^{-1}$   
 (3)  $540.48 \text{ S cm}^2 \text{ mol}^{-1}$   
 (4)  $201.28 \text{ S cm}^2 \text{ mol}^{-1}$

64. Which one of the following polymers is prepared by addition polymerisation ?

- (1) Nylon-66  
 (2) Novolac  
 (3) Dacron  
 (4) Teflon

65. The  $\text{pK}_b$  of dimethylamine and  $\text{pK}_a$  of acetic acid are 3.27 and 4.77 respectively at T (K). The correct option for the pH of dimethylammonium acetate solution is :

- (1) 5.50  
 (2) 7.75  
 (3) 6.25  
 (4) 8.50

66. A particular station of All India Radio, New Delhi, broadcasts on a frequency of 1,368 kHz (kilohertz). The wavelength of the electromagnetic radiation emitted by the transmitter is : [speed of light,  $c = 3.0 \times 10^8 \text{ ms}^{-1}$ ]

- (1) 219.2 m  
 (2) 2192 m  
 (3) 21.92 cm  
 (4) 219.3 m

67. Right option for the number of tetrahedral and octahedral voids in hexagonal primitive unit cell are :

- (1) 6, 12  
 (2) 2, 1  
 (3) 12, 6  
 (4) 8, 4

68. The following solutions were prepared by dissolving 10 g of glucose ( $C_6H_{12}O_6$ ) in 250 ml of water ( $P_1$ ), 10 g of urea ( $CH_4N_2O$ ) in 250 ml of water ( $P_2$ ) and 10 g of sucrose ( $C_{12}H_{22}O_{11}$ ) in 250 ml of water ( $P_3$ ). The right option for the decreasing order of osmotic pressure of these solutions is :

- (1)  $P_1 > P_2 > P_3$
- (2)  $P_2 > P_3 > P_1$
- (3)  $P_3 > P_1 > P_2$
- (4)  $P_2 > P_1 > P_3$

69. Match List - I with List - II.

List - I	List - II
(a) $PCl_5$	(i) Square pyramidal
(b) $SF_6$	(ii) Trigonal planar
(c) $BrF_5$	(iii) Octahedral
(d) $BF_3$	(iv) Trigonal bipyramidal

Choose the **correct** answer from the options given below.

- (1) (a)-(ii), (b)-(iii), (c)-(iv), (d)-(i)
- (2) (a)-(iii), (b)-(i), (c)-(iv), (d)-(ii)
- (3) (a)-(iv), (b)-(iii), (c)-(ii), (d)-(i)
- (4) (a)-(iv), (b)-(iii), (c)-(i), (d)-(ii)

70. Ethylene diaminetetraacetate (EDTA) ion is :

- (1) Unidentate ligand
- (2) Bidentate ligand with two "N" donor atoms
- (3) Tridentate ligand with three "N" donor atoms
- (4) Hexadentate ligand with four "O" and two "N" donor atoms

71. The right option for the statement "Tyndall effect is exhibited by", is :

- (1) Glucose solution
- (2) Starch solution
- (3) Urea solution
- (4) NaCl solution

72. The major product formed in dehydrohalogenation reaction of 2-Bromo pentane is Pent-2-ene. This product formation is based on ?

- (1) Hund's Rule
- (2) Hofmann Rule
- (3) Huckel's Rule
- (4) Saytzeff's Rule

73. Dihedral angle of least stable conformer of ethane is :

- (1)  $180^\circ$
- (2)  $60^\circ$
- (3)  $0^\circ$
- (4)  $120^\circ$

74. The major product of the following chemical reaction is :

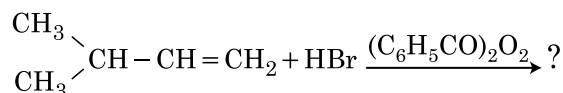

- (1)  $\begin{array}{c} \text{CH}_3 \\ \diagdown \\ \text{CH} - \text{CH}_2 - \text{CH}_2 - \text{O} - \text{COC}_6\text{H}_5 \\ \diagup \\ \text{CH}_3 \end{array}$
- (2)  $\begin{array}{c} \text{CH}_3 \\ \diagdown \\ \text{CH} - \text{CH} - \text{CH}_3 \\ \diagup \quad | \\ \text{CH}_3 \quad \text{Br} \end{array}$
- (3)  $\begin{array}{c} \text{CH}_3 \\ \diagdown \\ \text{CBr} - \text{CH}_2 - \text{CH}_3 \\ \diagup \\ \text{CH}_3 \end{array}$
- (4)  $\begin{array}{c} \text{CH}_3 \\ \diagdown \\ \text{CH} - \text{CH}_2 - \text{CH}_2 - \text{Br} \\ \diagup \\ \text{CH}_3 \end{array}$

75. The correct structure of 2,6-Dimethyl-dec-4-ene is :

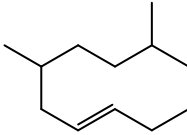
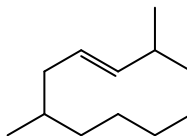
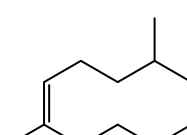
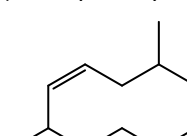
- (1) 
- (2) 
- (3) 
- (4) 

76. Zr ( $Z = 40$ ) and Hf ( $Z = 72$ ) have similar atomic and ionic radii because of :

- (1) diagonal relationship
- (2) lanthanoid contraction
- (3) having similar chemical properties
- (4) belonging to same group

77. Given below are two statements :

**Statement I :**

Aspirin and Paracetamol belong to the class of narcotic analgesics.

**Statement II :**

Morphine and Heroin are non-narcotic analgesics.

In the light of the above statements, choose the **correct** answer from the options given below.

- (1) Both **Statement I** and **Statement II** are false.
  - (2) **Statement I** is correct but **Statement II** is false.
  - (3) **Statement I** is incorrect but **Statement II** is true.
  - (4) Both **Statement I** and **Statement II** are true.
78. Which one of the following methods can be used to obtain highly pure metal which is liquid at room temperature ?
- (1) Chromatography
  - (2) Distillation
  - (3) Zone refining
  - (4) Electrolysis

79. The compound which shows metamerism is :

- (1)  $C_3H_8O$
- (2)  $C_3H_6O$
- (3)  $C_4H_{10}O$
- (4)  $C_5H_{12}$

80. Which of the following reactions is the metal displacement reaction ? Choose the right option.

- (1)  $Cr_2O_3 + 2Al \xrightarrow{\Delta} Al_2O_3 + 2Cr$
- (2)  $Fe + 2HCl \rightarrow FeCl_2 + H_2 \uparrow$
- (3)  $2Pb(NO_3)_2 \rightarrow 2PbO + 4NO_2 + O_2 \uparrow$
- (4)  $2KClO_3 \xrightarrow{\Delta} 2KCl + 3O_2$

81. The **incorrect** statement among the following is :

- (1) Most of the trivalent Lanthanoid ions are colorless in the solid state.
- (2) Lanthanoids are good conductors of heat and electricity.
- (3) Actinoids are highly reactive metals, especially when finely divided.
- (4) Actinoid contraction is greater for element to element than Lanthanoid contraction.

82. Which one among the following is the correct option for right relationship between  $C_P$  and  $C_V$  for one mole of ideal gas ?

- (1)  $C_P - C_V = R$
- (2)  $C_P = RC_V$
- (3)  $C_V = RC_P$
- (4)  $C_P + C_V = R$

83. The correct sequence of bond enthalpy of 'C-X' bond is :

- (1)  $CH_3 - F > CH_3 - Cl > CH_3 - Br > CH_3 - I$
- (2)  $CH_3 - F < CH_3 - Cl > CH_3 - Br > CH_3 - I$
- (3)  $CH_3 - Cl > CH_3 - F > CH_3 - Br > CH_3 - I$
- (4)  $CH_3 - F < CH_3 - Cl < CH_3 - Br < CH_3 - I$

84. An organic compound contains 78% (by wt.) carbon and remaining percentage of hydrogen. The right option for the empirical formula of this compound is : [Atomic wt. of C is 12, H is 1]

- (1)  $CH_2$
- (2)  $CH_3$
- (3)  $CH_4$
- (4)  $CH$

85. For a reaction  $A \rightarrow B$ , enthalpy of reaction is  $-4.2 \text{ kJ mol}^{-1}$  and enthalpy of activation is  $9.6 \text{ kJ mol}^{-1}$ . The correct potential energy profile for the reaction is shown in option.

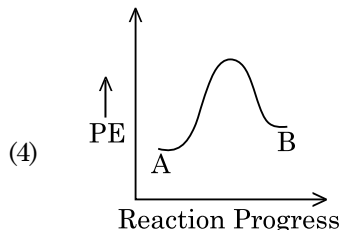
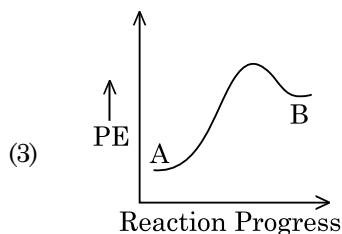
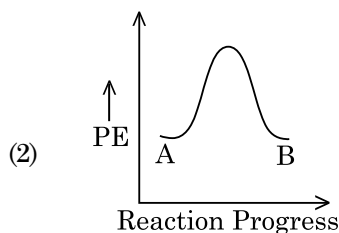
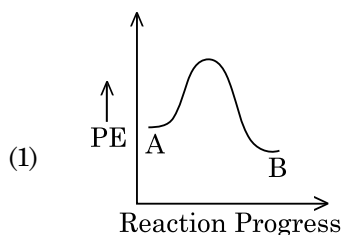



## Section - B (Chemistry)

86. The molar conductivity of 0.007 M acetic acid is  $20 \text{ S cm}^2 \text{ mol}^{-1}$ . What is the dissociation constant of acetic acid? Choose the correct option.

$$\left[ \begin{array}{l} \Lambda^\circ_{\text{H}^+} = 350 \text{ S cm}^2 \text{ mol}^{-1} \\ \Lambda^\circ_{\text{CH}_3\text{COO}^-} = 50 \text{ S cm}^2 \text{ mol}^{-1} \end{array} \right]$$

- (1)  $2.50 \times 10^{-4} \text{ mol L}^{-1}$   
 (2)  $1.75 \times 10^{-5} \text{ mol L}^{-1}$   
 (3)  $2.50 \times 10^{-5} \text{ mol L}^{-1}$   
 (4)  $1.75 \times 10^{-4} \text{ mol L}^{-1}$
87. The product formed in the following chemical reaction is :

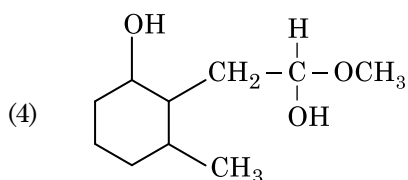
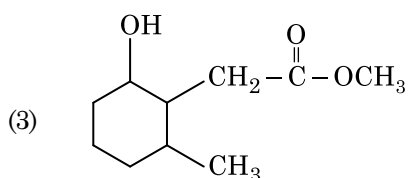
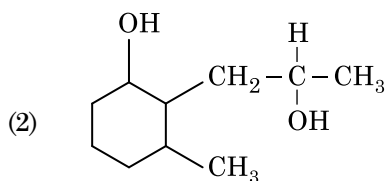
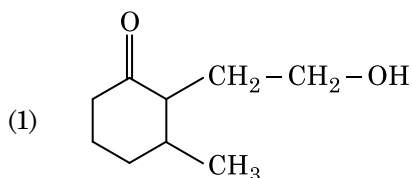
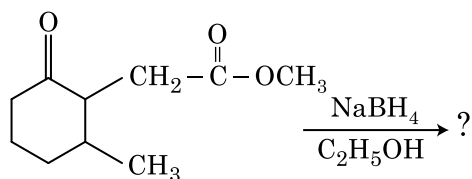

88. Match List - I with List - II.

List - I	List - II
(a) $2\text{SO}_2(\text{g}) + \text{O}_2(\text{g}) \rightarrow 2\text{SO}_3(\text{g})$	(i) Acid rain
(b) $\text{HOCl}(\text{g}) \xrightarrow{h\nu} \cdot\text{OH} + \cdot\text{Cl}$	(ii) Smog
(c) $\text{CaCO}_3 + \text{H}_2\text{SO}_4 \rightarrow \text{CaSO}_4 + \text{H}_2\text{O} + \text{CO}_2$	(iii) Ozone depletion
(d) $\text{NO}_2(\text{g}) \xrightarrow{h\nu} \text{NO}(\text{g}) + \text{O}(\text{g})$	(iv) Tropospheric pollution

Choose the **correct** answer from the options given below.

- (1) (a)-(ii), (b)-(iii), (c)-(iv), (d)-(i)  
 (2) (a)-(iv), (b)-(iii), (c)-(i), (d)-(ii)  
 (3) (a)-(iii), (b)-(ii), (c)-(iv), (d)-(i)  
 (4) (a)-(i), (b)-(ii), (c)-(iii), (d)-(iv)

89. Match List - I with List - II.

List - I	List - II
(a) $\xrightarrow[\text{CuCl}]{\text{CO, HCl, Anhyd. AlCl}_3}$	(i) Hell-Volhard-Zelinsky reaction
(b) $\text{R}-\overset{\text{O}}{\parallel}{\text{C}}-\text{CH}_3 + \text{NaOX} \longrightarrow$	(ii) Gattermann-Koch reaction
(c) $\text{R}-\text{CH}_2-\text{OH} + \text{R}'\text{COOH} \xrightarrow{\text{Conc. H}_2\text{SO}_4}$	(iii) Haloform reaction
(d) $\text{R}-\text{CH}_2\text{COOH} \xrightarrow[\text{(ii) H}_2\text{O}]{\text{(i) X}_2/\text{Red P}}$	(iv) Esterification

Choose the **correct** answer from the options given below.

- (1) (a)-(iii), (b)-(ii), (c)-(i), (d)-(iv)  
 (2) (a)-(i), (b)-(iv), (c)-(iii), (d)-(ii)  
 (3) (a)-(ii), (b)-(iii), (c)-(iv), (d)-(i)  
 (4) (a)-(iv), (b)-(i), (c)-(ii), (d)-(iii)

90. In which one of the following arrangements the given sequence is not strictly according to the properties indicated against it?

- (1)  $\text{H}_2\text{O} < \text{H}_2\text{S}$  : Increasing  $\text{pK}_a$   
 $< \text{H}_2\text{Se} < \text{H}_2\text{Te}$  values
- (2)  $\text{NH}_3 < \text{PH}_3$  : Increasing  
 $< \text{AsH}_3 < \text{SbH}_3$  acidic character
- (3)  $\text{CO}_2 < \text{SiO}_2$  : Increasing  
 $< \text{SnO}_2 < \text{PbO}_2$  oxidizing power
- (4)  $\text{HF} < \text{HCl}$  : Increasing acidic  
 $< \text{HBr} < \text{HI}$  strength

91. The reagent 'R' in the given sequence of chemical reaction is :

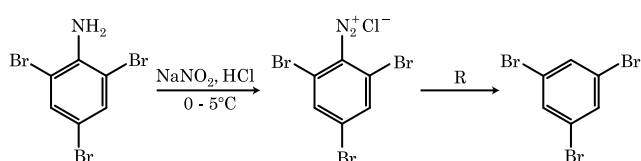

- (1)  $\text{CH}_3\text{CH}_2\text{OH}$   
 (2)  $\text{HI}$   
 (3)  $\text{CuCN/KCN}$   
 (4)  $\text{H}_2\text{O}$

92. For irreversible expansion of an ideal gas under isothermal condition, the correct option is :

- (1)  $\Delta U \neq 0, \Delta S_{\text{total}} \neq 0$   
 (2)  $\Delta U = 0, \Delta S_{\text{total}} \neq 0$   
 (3)  $\Delta U \neq 0, \Delta S_{\text{total}} = 0$   
 (4)  $\Delta U = 0, \Delta S_{\text{total}} = 0$

93. The correct option for the value of vapour pressure of a solution at  $45^\circ\text{C}$  with benzene to octane in molar ratio 3 : 2 is :

[At  $45^\circ\text{C}$  vapour pressure of benzene is 280 mm Hg and that of octane is 420 mm Hg. Assume Ideal gas]

- (1) 168 mm of Hg  
 (2) 336 mm of Hg  
 (3) 350 mm of Hg  
 (4) 160 mm of Hg

94. Match List - I with List - II.

List - I		List - II	
(a)	$[\text{Fe}(\text{CN})_6]^{3-}$	(i)	5.92 BM
(b)	$[\text{Fe}(\text{H}_2\text{O})_6]^{3+}$	(ii)	0 BM
(c)	$[\text{Fe}(\text{CN})_6]^{4-}$	(iii)	4.90 BM
(d)	$[\text{Fe}(\text{H}_2\text{O})_6]^{2+}$	(iv)	1.73 BM

Choose the **correct** answer from the options given below.

- (1) (a)-(ii), (b)-(iv), (c)-(iii), (d)-(i)  
 (2) (a)-(i), (b)-(iii), (c)-(iv), (d)-(ii)  
 (3) (a)-(iv), (b)-(i), (c)-(ii), (d)-(iii)  
 (4) (a)-(iv), (b)-(ii), (c)-(i), (d)-(iii)

95. The slope of Arrhenius Plot  $\left(\ln k \text{ v/s } \frac{1}{T}\right)$  of first order reaction is  $-5 \times 10^3 \text{ K}$ . The value of  $E_a$  of the reaction is. Choose the correct option for your answer.

[Given  $R = 8.314 \text{ J K}^{-1} \text{ mol}^{-1}$ ]

- (1)  $83.0 \text{ kJ mol}^{-1}$   
 (2)  $166 \text{ kJ mol}^{-1}$   
 (3)  $-83 \text{ kJ mol}^{-1}$   
 (4)  $41.5 \text{ kJ mol}^{-1}$

96. From the following pairs of ions which one is not an iso-electronic pair?

- (1)  $\text{Na}^+, \text{Mg}^{2+}$   
 (2)  $\text{Mn}^{2+}, \text{Fe}^{3+}$   
 (3)  $\text{Fe}^{2+}, \text{Mn}^{2+}$   
 (4)  $\text{O}^{2-}, \text{F}^-$

97. Choose the correct option for the total pressure (in atm.) in a mixture of 4 g  $\text{O}_2$  and 2 g  $\text{H}_2$  confined in a total volume of one litre at  $0^\circ\text{C}$  is :

[Given  $R = 0.082 \text{ L atm mol}^{-1} \text{ K}^{-1}$ ,  $T = 273 \text{ K}$ ]

- (1) 2.602  
 (2) 25.18  
 (3) 26.02  
 (4) 2.518

98.  $\text{CH}_3\text{CH}_2\text{COO}^- \text{Na}^+ + \frac{\text{NaOH}, + ?}{\text{Heat}} \rightarrow \text{CH}_3\text{CH}_3 + \text{Na}_2\text{CO}_3$ .

Consider the above reaction and identify the missing reagent/chemical.

- (1) Red Phosphorus  
 (2)  $\text{CaO}$   
 (3) DIBAL-H  
 (4)  $\text{B}_2\text{H}_6$

99. The intermediate compound 'X' in the following chemical reaction is :

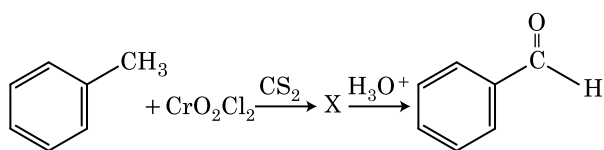

- (1)
- (2)
- (3)
- (4)

100. Which of the following molecules is non-polar in nature ?
- (1)  $\text{CH}_2\text{O}$   
 (2)  $\text{SbCl}_5$   
 (3)  $\text{NO}_2$   
 (4)  $\text{POCl}_3$

### Section - A (Biology : Botany)

101. In the equation  $\text{GPP} - \text{R} = \text{NPP}$   
 R represents :
- (1) Retardation factor  
 (2) Environment factor  
 (3) Respiration losses  
 (4) Radiant energy
102. Which of the following plants is monoecious ?
- (1) Chara  
 (2) *Marchantia polymorpha*  
 (3) *Cycas circinalis*  
 (4) *Carica papaya*

103. Which of the following is a **correct** sequence of steps in a PCR (Polymerase Chain Reaction) ?

- (1) Denaturation, Extension, Annealing  
 (2) Extension, Denaturation, Annealing  
 (3) Annealing, Denaturation, Extension  
 (4) Denaturation, Annealing, Extension

104. Match List - I with List - II.

List - I		List - II	
(a)	Lenticels	(i)	Phellogen
(b)	Cork cambium	(ii)	Suberin deposition
(c)	Secondary cortex	(iii)	Exchange of gases
(d)	Cork	(iv)	Phelloderm

Choose the **correct** answer from the options given below.

- |     | (a)   | (b)   | (c)   | (d)   |
|-----|-------|-------|-------|-------|
| (1) | (iii) | (i)   | (iv)  | (ii)  |
| (2) | (ii)  | (iii) | (iv)  | (i)   |
| (3) | (iv)  | (ii)  | (i)   | (iii) |
| (4) | (iv)  | (i)   | (iii) | (ii)  |

105. Diadelphous stamens are found in :

- (1) Citrus  
 (2) Pea  
 (3) China rose and citrus  
 (4) China rose

106. The plant hormone used to destroy weeds in a field is :

- (1) NAA  
 (2) 2, 4-D  
 (3) IBA  
 (4) IAA

107. DNA strands on a gel stained with ethidium bromide when viewed under UV radiation, appear as :

- (1) Bright orange bands  
 (2) Dark red bands  
 (3) Bright blue bands  
 (4) Yellow bands

108. The term used for transfer of pollen grains from anthers of one plant to stigma of a different plant which, during pollination, brings genetically different types of pollen grains to stigma, is :

- (1) Geitonogamy  
 (2) Chasmogamy  
 (3) Cleistogamy  
 (4) Xenogamy

- 109.** Which of the following stages of meiosis involves division of centromere ?
- (1) Metaphase II
  - (2) Anaphase II
  - (3) Telophase II
  - (4) Metaphase I
- 110.** When the centromere is situated in the middle of two equal arms of chromosomes, the chromosome is referred as :
- (1) Telocentric
  - (2) Sub-metacentric
  - (3) Acrocentric
  - (4) Metacentric
- 111.** In spite of interspecific competition in nature, which mechanism the competing species might have evolved for their survival ?
- (1) Competitive release
  - (2) Mutualism
  - (3) Predation
  - (4) Resource partitioning
- 112.** The production of gametes by the parents, formation of zygotes, the  $F_1$  and  $F_2$  plants, can be understood from a diagram called :
- (1) Punnett square
  - (2) Punnett square
  - (3) Net square
  - (4) Bullet square
- 113.** The site of perception of light in plants during photoperiodism is :
- (1) Stem
  - (2) Axillary bud
  - (3) Leaf
  - (4) Shoot apex
- 114.** The factor that leads to Founder effect in a population is :
- (1) Genetic recombination
  - (2) Mutation
  - (3) Genetic drift
  - (4) Natural selection
- 115.** When gene targeting involving gene amplification is attempted in an individual's tissue to treat disease, it is known as :
- (1) Gene therapy
  - (2) Molecular diagnosis
  - (3) Safety testing
  - (4) Biopiracy

- 116.** Which of the following is an **incorrect** statement ?

- (1) Microbodies are present both in plant and animal cells.
- (2) The perinuclear space forms a barrier between the materials present inside the nucleus and that of the cytoplasm.
- (3) Nuclear pores act as passages for proteins and RNA molecules in both directions between nucleus and cytoplasm.
- (4) Mature sieve tube elements possess a conspicuous nucleus and usual cytoplasmic organelles.

- 117.** Match **List - I** with **List - II**.

List - I		List - II	
(a)	Cells with active cell division capacity	(i)	Vascular tissues
(b)	Tissue having all cells similar in structure and function	(ii)	Meristematic tissue
(c)	Tissue having different types of cells	(iii)	Sclereids
(d)	Dead cells with highly thickened walls and narrow lumen	(iv)	Simple tissue

Select the **correct** answer from the options given below.

- |     |            |            |            |            |
|-----|------------|------------|------------|------------|
|     | <b>(a)</b> | <b>(b)</b> | <b>(c)</b> | <b>(d)</b> |
| (1) | (iv)       | (iii)      | (ii)       | (i)        |
| (2) | (i)        | (ii)       | (iii)      | (iv)       |
| (3) | (iii)      | (ii)       | (iv)       | (i)        |
| (4) | (ii)       | (iv)       | (i)        | (iii)      |

- 118.** Match **List - I** with **List - II**.

List - I		List - II	
(a)	Cristae	(i)	Primary constriction in chromosome
(b)	Thylakoids	(ii)	Disc-shaped sacs in Golgi apparatus
(c)	Centromere	(iii)	Infoldings in mitochondria
(d)	Cisternae	(iv)	Flattened membranous sacs in stroma of plastids

Choose the **correct** answer from the options given below.

- |     |            |            |            |            |
|-----|------------|------------|------------|------------|
|     | <b>(a)</b> | <b>(b)</b> | <b>(c)</b> | <b>(d)</b> |
| (1) | (i)        | (iv)       | (iii)      | (ii)       |
| (2) | (iii)      | (iv)       | (i)        | (ii)       |
| (3) | (ii)       | (iii)      | (iv)       | (i)        |
| (4) | (iv)       | (iii)      | (ii)       | (i)        |

119. During the purification process for recombinant DNA technology, addition of chilled ethanol precipitates out :
- (1) DNA
  - (2) Histones
  - (3) Polysaccharides
  - (4) RNA
120. Which of the following are **not** secondary metabolites in plants ?
- (1) Amino acids, glucose
  - (2) Vinblastin, curcumin
  - (3) Rubber, gums
  - (4) Morphine, codeine
121. Which of the following algae contains mannitol as reserve food material ?
- (1) *Gracilaria*
  - (2) *Volvox*
  - (3) *Ulothrix*
  - (4) *Ectocarpus*
122. Gemmae are present in :
- (1) Pteridophytes
  - (2) Some Gymnosperms
  - (3) Some Liverworts
  - (4) Mosses
123. Which of the following statements is **not** correct ?
- (1) Pyramid of biomass in sea is generally upright.
  - (2) Pyramid of energy is always upright.
  - (3) Pyramid of numbers in a grassland ecosystem is upright.
  - (4) Pyramid of biomass in sea is generally inverted.
124. Plants follow different pathways in response to environment or phases of life to form different kinds of structures. This ability is called :
- (1) Flexibility
  - (2) Plasticity
  - (3) Maturity
  - (4) Elasticity
125. Amensalism can be represented as :
- (1) Species A (+) ; Species B (+)
  - (2) Species A (-) ; Species B (-)
  - (3) Species A (+) ; Species B (0)
  - (4) Species A (-) ; Species B (0)
126. Complete the flow chart on central dogma.
- (a)  $\text{DNA} \xrightarrow{(b)} \text{mRNA} \xrightarrow{(c)} (d)$
- (1) (a)-Translation; (b)-Replication; (c)-Transcription; (d)-Transduction
  - (2) (a)-Replication; (b)-Transcription; (c)-Translation; (d)-Protein
  - (3) (a)-Transduction; (b)-Translation; (c)-Replication; (d)-Protein
  - (4) (a)-Replication; (b)-Transcription; (c)-Transduction; (d)-Protein
127. Genera like *Selaginella* and *Salvinia* produce two kinds of spores. Such plants are known as :
- (1) Heterosorus
  - (2) Homosporous
  - (3) Heterosporous
  - (4) Homosorus
128. Match List - I with List - II.
- | List - I |                 | List - II |   |
|----------|-----------------|-----------|---|
| (a)      | Cohesion        | (i)       | More attraction in liquid phase         |
| (b)      | Adhesion        | (ii)      | Mutual attraction among water molecules |
| (c)      | Surface tension | (iii)     | Water loss in liquid phase              |
| (d)      | Guttation       | (iv)      | Attraction towards polar surfaces       |
- Choose the **correct** answer from the options given below.
- |     |            |            |            |            |
|-----|------------|------------|------------|------------|
|     | <b>(a)</b> | <b>(b)</b> | <b>(c)</b> | <b>(d)</b> |
| (1) | (iv)       | (iii)      | (ii)       | (i)        |
| (2) | (iii)      | (i)        | (iv)       | (ii)       |
| (3) | (ii)       | (i)        | (iv)       | (iii)      |
| (4) | (ii)       | (iv)       | (i)        | (iii)      |
129. Mutations in plant cells can be induced by :
- (1) Infrared rays
  - (2) Gamma rays
  - (3) Zeatin
  - (4) Kinetin
130. Which of the following is **not** an application of PCR (Polymerase Chain Reaction) ?
- (1) Gene amplification
  - (2) Purification of isolated protein
  - (3) Detection of gene mutation
  - (4) Molecular diagnosis

131. The first stable product of  $\text{CO}_2$  fixation in sorghum is :
- (1) Oxaloacetic acid
  - (2) Succinic acid
  - (3) Phosphoglyceric acid
  - (4) Pyruvic acid
132. Which of the following algae produce Carrageen ?
- (1) Brown algae
  - (2) Red algae
  - (3) Blue-green algae
  - (4) Green algae

133. Match List - I with List - II.

List - I		List - II	
(a)	Protoplast fusion	(i)	Totipotency
(b)	Plant tissue culture	(ii)	Pomato
(c)	Meristem culture	(iii)	Somaclones
(d)	Micropropagation	(iv)	Virus free plants

Choose the **correct** answer from the options given below.

- |  |            |            |            |            |
|--|------------|------------|------------|------------|
|  | <b>(a)</b> | <b>(b)</b> | <b>(c)</b> | <b>(d)</b> |
|--|------------|------------|------------|------------|
- (1) (ii) (i) (iv) (iii)
  - (2) (iii) (iv) (i) (ii)
  - (3) (iv) (iii) (ii) (i)
  - (4) (iii) (iv) (ii) (i)
134. A typical angiosperm embryo sac at maturity is :
- (1) 7-nucleate and 8-celled
  - (2) 7-nucleate and 7-celled
  - (3) 8-nucleate and 8-celled
  - (4) 8-nucleate and 7-celled
135. The amount of nutrients, such as carbon, nitrogen, phosphorus and calcium present in the soil at any given time, is referred as :
- (1) Climax community
  - (2) Standing state
  - (3) Standing crop
  - (4) Climax

### Section - B (Biology : Botany)

136. Which of the following statements is **incorrect** ?
- (1) Stroma lamellae have PS I only and lack NADP reductase.
  - (2) Grana lamellae have both PS I and PS II.
  - (3) Cyclic photophosphorylation involves both PS I and PS II.
  - (4) Both ATP and  $\text{NADPH} + \text{H}^+$  are synthesized during non-cyclic photophosphorylation.

137. Identify the **correct** statement.
- (1) RNA polymerase binds with Rho factor to terminate the process of transcription in bacteria.
  - (2) The coding strand in a transcription unit is copied to an mRNA.
  - (3) Split gene arrangement is characteristic of prokaryotes.
  - (4) In capping, methyl guanosine triphosphate is added to the 3' end of hnRNA.

138. Match Column - I with Column - II.

Column - I		Column - II	
(a)	<i>Nitrococcus</i>	(i)	Denitrification
(b)	<i>Rhizobium</i>	(ii)	Conversion of ammonia to nitrite
(c)	<i>Thiobacillus</i>	(iii)	Conversion of nitrite to nitrate
(d)	<i>Nitrobacter</i>	(iv)	Conversion of atmospheric nitrogen to ammonia

Choose the **correct** answer from options given below.

- |  |            |            |            |            |
|--|------------|------------|------------|------------|
|  | <b>(a)</b> | <b>(b)</b> | <b>(c)</b> | <b>(d)</b> |
|--|------------|------------|------------|------------|
- (1) (i) (ii) (iii) (iv)
  - (2) (iii) (i) (iv) (ii)
  - (3) (iv) (iii) (ii) (i)
  - (4) (ii) (iv) (i) (iii)
139. What is the role of RNA polymerase III in the process of transcription in eukaryotes ?
- (1) Transcribes tRNA, 5s rRNA and snRNA
  - (2) Transcribes precursor of mRNA
  - (3) Transcribes only snRNAs
  - (4) Transcribes rRNAs (28S, 18S and 5.8S)

140. Match List - I with List - II.

List - I		List - II	
(a)	S phase	(i)	Proteins are synthesized
(b)	G <sub>2</sub> phase	(ii)	Inactive phase
(c)	Quiescent stage	(iii)	Interval between mitosis and initiation of DNA replication
(d)	G <sub>1</sub> phase	(iv)	DNA replication

Choose the **correct** answer from the options given below.

- |  |            |            |            |            |
|--|------------|------------|------------|------------|
|  | <b>(a)</b> | <b>(b)</b> | <b>(c)</b> | <b>(d)</b> |
|--|------------|------------|------------|------------|
- (1) (iv) (ii) (iii) (i)
  - (2) (iv) (i) (ii) (iii)
  - (3) (ii) (iv) (iii) (i)
  - (4) (iii) (ii) (i) (iv)

141. Select the **correct** pair.
- (1) In dicot leaves, vascular bundles are surrounded by large thick-walled cells - Conjunctive tissue
  - (2) Cells of medullary rays that form part of cambial ring - Interfascicular cambium
  - (3) Loose parenchyma cells rupturing the epidermis and forming a lens-shaped opening in bark - Spongy parenchyma
  - (4) Large colorless empty cells in the epidermis of grass leaves - Subsidiary cells
142. In some members of which of the following pairs of families, pollen grains retain their viability for months after release ?
- (1) Poaceae ; Leguminosae
  - (2) Poaceae ; Solanaceae
  - (3) Rosaceae ; Leguminosae
  - (4) Poaceae ; Rosaceae
143. Which of the following statements is **correct** ?
- (1) Fusion of protoplasts between two motile on non-motile gametes is called plasmogamy.
  - (2) Organisms that depend on living plants are called saprophytes.
  - (3) Some of the organisms can fix atmospheric nitrogen in specialized cells called sheath cells.
  - (4) Fusion of two cells is called Karyogamy.
144. Now a days it is possible to detect the mutated gene causing cancer by allowing radioactive probe to hybridise its complimentary DNA in a clone of cells, followed by its detection using autoradiography because :
- (1) mutated gene completely and clearly appears on a photographic film.
  - (2) mutated gene does not appear on a photographic film as the probe has no complementarity with it.
  - (3) mutated gene does not appear on photographic film as the probe has complementarity with it.
  - (4) mutated gene partially appears on a photographic film.
145. Plasmid pBR322 has PstI restriction enzyme site within gene  $amp^R$  that confers ampicillin resistance. If this enzyme is used for inserting a gene for  $\beta$ -galactoside production and the recombinant plasmid is inserted in an *E.coli* strain
- (1) the transformed cells will have the ability to resist ampicillin as well as produce  $\beta$ -galactoside.
  - (2) it will lead to lysis of host cell.
  - (3) it will be able to produce a novel protein with dual ability.
  - (4) it will not be able to confer ampicillin resistance to the host cell.
146. Which of the following statements is **incorrect** ?
- (1) In ETC (Electron Transport Chain), one molecule of  $NADH + H^+$  gives rise to 2 ATP molecules, and one  $FADH_2$  gives rise to 3 ATP molecules.
  - (2) ATP is synthesized through complex V.
  - (3) Oxidation-reduction reactions produce proton gradient in respiration.
  - (4) During aerobic respiration, role of oxygen is limited to the terminal stage.
147. DNA fingerprinting involves identifying differences in some specific regions in DNA sequence, called as :
- (1) Repetitive DNA
  - (2) Single nucleotides
  - (3) Polymorphic DNA
  - (4) Satellite DNA
148. Match **Column - I** with **Column - II**.
- | Column - I   | Column - II      |
|--|------------------|
| (a) $\% \frac{\phi}{\psi} K_{(5)} C_{1+2+(2)} A_{(9)+1} \underline{G}_1$         | (i) Brassicaceae |
| (b) $\oplus \frac{\phi}{\psi} K_{(5)} \overbrace{C_{(5)} A_5} G_2$               | (ii) Liliaceae   |
| (c) $\oplus \frac{\phi}{\psi} \overbrace{P_{(3+3)} A_{3+3}} \underline{G}_{(3)}$ | (iii) Fabaceae   |
| (d) $\oplus \frac{\phi}{\psi} K_{2+2} C_4 A_{2-4} \underline{G}_{(2)}$           | (iv) Solanaceae  |
- Select the **correct** answer from the options given below.
- |     | (a)   | (b)   | (c)   | (d)   |
|-----|-------|-------|-------|-------|
| (1) | (i)   | (ii)  | (iii) | (iv)  |
| (2) | (ii)  | (iii) | (iv)  | (i)   |
| (3) | (iv)  | (ii)  | (i)   | (iii) |
| (4) | (iii) | (iv)  | (ii)  | (i)   |

149. In the exponential growth equation  $N_t = N_0 e^{rt}$ ,  $e$  represents :
- (1) The base of exponential logarithms
  - (2) The base of natural logarithms
  - (3) The base of geometric logarithms
  - (4) The base of number logarithms

150. Match List - I with List - II.

List - I		List - II	
(a)	Protein	(i)	C = C double bonds
(b)	Unsaturated fatty acid	(ii)	Phosphodiester bonds
(c)	Nucleic acid	(iii)	Glycosidic bonds
(d)	Polysaccharide	(iv)	Peptide bonds

Choose the **correct** answer from the options given below.

- |     | (a)  | (b)   | (c)   | (d)   |
|-----|------|-------|-------|-------|
| (1) | (i)  | (iv)  | (iii) | (ii)  |
| (2) | (ii) | (i)   | (iv)  | (iii) |
| (3) | (iv) | (iii) | (i)   | (ii)  |
| (4) | (iv) | (i)   | (ii)  | (iii) |

### Section - A (Biology : Zoology)

151. Which stage of meiotic prophase shows terminalisation of chiasmata as its distinctive feature ?
- (1) Zygotene
  - (2) Diakinesis
  - (3) Pachytene
  - (4) Leptotene
152. Which one of the following organisms bears hollow and pneumatic long bones ?
- (1) *Hemidactylus*
  - (2) *Macropus*
  - (3) *Ornithorhynchus*
  - (4) *Neophron*
153. Match the following :

List - I		List - II	
(a)	<i>Physalia</i>	(i)	Pearl oyster
(b)	<i>Limulus</i>	(ii)	Portuguese Man of War
(c)	<i>Ancylostoma</i>	(iii)	Living fossil
(d)	<i>Pinctada</i>	(iv)	Hookworm

Choose the **correct** answer from the options given below.

- |     | (a)  | (b)   | (c)   | (d)  |
|-----|------|-------|-------|------|
| (1) | (iv) | (i)   | (iii) | (ii) |
| (2) | (ii) | (iii) | (iv)  | (i)  |
| (3) | (i)  | (iv)  | (iii) | (ii) |
| (4) | (ii) | (iii) | (i)   | (iv) |

154. Which of the following characteristics is **incorrect** with respect to cockroach ?
- (1) Hypopharynx lies within the cavity enclosed by the mouth parts.
  - (2) In females, 7<sup>th</sup>-9<sup>th</sup> sterna together form a genital pouch.
  - (3) 10<sup>th</sup> abdominal segment in both sexes, bears a pair of anal cerci.
  - (4) A ring of gastric caeca is present at the junction of midgut and hind gut.
155. Chronic auto immune disorder affecting neuro muscular junction leading to fatigue, weakening and paralysis of skeletal muscle is called as :
- (1) Muscular dystrophy
  - (2) Myasthenia gravis
  - (3) Gout
  - (4) Arthritis
156. Persons with 'AB' blood group are called as "Universal recipients". This is due to :
- (1) Absence of antigens A and B in plasma
  - (2) Presence of antibodies, anti-A and anti-B, on RBCs
  - (3) Absence of antibodies, anti-A and anti-B, in plasma
  - (4) Absence of antigens A and B on the surface of RBCs
157. Erythropoietin hormone which stimulates R.B.C. formation is produced by :
- (1) The cells of rostral adenohypophysis
  - (2) The cells of bone marrow
  - (3) Juxtaglomerular cells of the kidney
  - (4) Alpha cells of pancreas
158. Veneral diseases can spread through :
- (a) Using sterile needles
  - (b) Transfusion of blood from infected person
  - (c) Infected mother to foetus
  - (d) Kissing
  - (e) Inheritance
- Choose the **correct** answer from the options given below.
- (1) (b), (c) and (d) only
  - (2) (b) and (c) only
  - (3) (a) and (c) only
  - (4) (a), (b) and (c) only



159. With regard to insulin choose correct options.

- C-peptide is not present in mature insulin.
- The insulin produced by rDNA technology has C-peptide.
- The pro-insulin has C-peptide.
- A-peptide and B-peptide of insulin are interconnected by disulphide bridges.

Choose the **correct** answer from the options given below.

- (b) and (c) only
- (a), (c) and (d) only
- (a) and (d) only
- (b) and (d) only

160. The partial pressures (in mm Hg) of oxygen ( $O_2$ ) and carbon dioxide ( $CO_2$ ) at alveoli (the site of diffusion) are :

- $pO_2 = 40$  and  $pCO_2 = 45$
- $pO_2 = 95$  and  $pCO_2 = 40$
- $pO_2 = 159$  and  $pCO_2 = 0.3$
- $pO_2 = 104$  and  $pCO_2 = 40$

161. Which enzyme is responsible for the conversion of inactive fibrinogens to fibrins ?

- Renin
- Epinephrine
- Thrombokinase
- Thrombin

162. Identify the **incorrect** pair.

- Toxin - Abrin
- Lectins - Concanavalin A
- Drugs - Ricin
- Alkaloids - Codeine

163. Match List - I with List - II.

List - I		List - II	
(a)	<i>Aspergillus niger</i>	(i)	Acetic Acid
(b)	<i>Acetobacter aceti</i>	(ii)	Lactic Acid
(c)	<i>Clostridium butylicum</i>	(iii)	Citric Acid
(d)	<i>Lactobacillus</i>	(iv)	Butyric Acid

Choose the **correct** answer from the options given below.

- |     | (a)   | (b)   | (c)   | (d)   |
|-----|-------|-------|-------|-------|
| (1) | (i)   | (ii)  | (iii) | (iv)  |
| (2) | (ii)  | (iii) | (i)   | (iv)  |
| (3) | (iv)  | (ii)  | (i)   | (iii) |
| (4) | (iii) | (i)   | (iv)  | (ii)  |

164. Which one of the following is an example of Hormone releasing IUD ?

- LNG 20
- Cu 7
- Multiload 375
- CuT

165. Match List - I with List - II.

List - I		List - II	
(a)	Metamerism	(i)	Coelenterata
(b)	Canal system	(ii)	Ctenophora
(c)	Comb plates	(iii)	Annelida
(d)	Cnidoblasts	(iv)	Porifera

Choose the **correct** answer from the options given below.

- |     | (a)   | (b)   | (c)  | (d)   |
|-----|-------|-------|------|-------|
| (1) | (iii) | (iv)  | (i)  | (ii)  |
| (2) | (iii) | (iv)  | (ii) | (i)   |
| (3) | (iv)  | (i)   | (ii) | (iii) |
| (4) | (iv)  | (iii) | (i)  | (ii)  |

166. A specific recognition sequence identified by endonucleases to make cuts at specific positions within the DNA is :

- Okazaki sequences
- Palindromic Nucleotide sequences
- Poly(A) tail sequences
- Degenerate primer sequence

167. Succus entericus is referred to as :

- Intestinal juice
- Gastric juice
- Chyme
- Pancreatic juice

168. Read the following statements.

- Metagenesis is observed in Helminths.
- Echinoderms are triploblastic and coelomate animals.
- Round worms have organ-system level of body organization.
- Comb plates present in ctenophores help in digestion.
- Water vascular system is characteristic of Echinoderms.

Choose the **correct** answer from the options given below.

- (a), (b) and (c) are correct
- (a), (d) and (e) are correct
- (b), (c) and (e) are correct
- (c), (d) and (e) are correct

169. Which is the "Only enzyme" that has "Capability" to catalyse Initiation, Elongation and Termination in the process of transcription in prokaryotes ?

- (1) DNA dependent RNA polymerase
- (2) DNA Ligase
- (3) DNase
- (4) DNA dependent DNA polymerase

170. The centriole undergoes duplication during :

- (1) Prophase
- (2) Metaphase
- (3) G<sub>2</sub> phase
- (4) S-phase

171. The organelles that are included in the endomembrane system are :

- (1) Endoplasmic reticulum, Golgi complex, Lysosomes and Vacuoles
- (2) Golgi complex, Mitochondria, Ribosomes and Lysosomes
- (3) Golgi complex, Endoplasmic reticulum, Mitochondria and Lysosomes
- (4) Endoplasmic reticulum, Mitochondria, Ribosomes and Lysosomes

172. Which one of the following belongs to the family Muscidae ?

- (1) Grasshopper
- (2) Cockroach
- (3) House fly
- (4) Fire fly

173. Dobson units are used to measure thickness of :

- (1) Stratosphere
- (2) Ozone
- (3) Troposphere
- (4) CFCs

174. In a cross between a male and female, both heterozygous for sickle cell anaemia gene, what percentage of the progeny will be diseased ?

- (1) 75%
- (2) 25%
- (3) 100%
- (4) 50%

175. Match List - I with List - II.

List - I		List - II	
(a)	Vaults	(i)	Entry of sperm through Cervix is blocked
(b)	IUDs	(ii)	Removal of Vas deferens
(c)	Vasectomy	(iii)	Phagocytosis of sperms within the Uterus
(d)	Tubectomy	(iv)	Removal of fallopian tube

Choose the **correct** answer from the options given below.

- |     | (a)   | (b)   | (c)   | (d)   |
|-----|-------|-------|-------|-------|
| (1) | (i)   | (iii) | (ii)  | (iv)  |
| (2) | (ii)  | (iv)  | (iii) | (i)   |
| (3) | (iii) | (i)   | (iv)  | (ii)  |
| (4) | (iv)  | (ii)  | (i)   | (iii) |

176. Select the favourable conditions required for the formation of oxyhaemoglobin at the alveoli.

- (1) Low pO<sub>2</sub>, high pCO<sub>2</sub>, more H<sup>+</sup>, higher temperature
- (2) High pO<sub>2</sub>, high pCO<sub>2</sub>, less H<sup>+</sup>, higher temperature
- (3) Low pO<sub>2</sub>, low pCO<sub>2</sub>, more H<sup>+</sup>, higher temperature
- (4) High pO<sub>2</sub>, low pCO<sub>2</sub>, less H<sup>+</sup>, lower temperature

177. For effective treatment of the disease, early diagnosis and understanding its pathophysiology is very important. Which of the following molecular diagnostic techniques is very useful for early detection ?

- (1) Southern Blotting Technique
- (2) ELISA Technique
- (3) Hybridization Technique
- (4) Western Blotting Technique

178. Receptors for sperm binding in mammals are present on :

- (1) Vitelline membrane
- (2) Perivitelline space
- (3) Zona pellucida
- (4) Corona radiata

179. Which of the following is **not** an objective of Biofortification in crops ?

- (1) Improve resistance to diseases
- (2) Improve vitamin content
- (3) Improve micronutrient and mineral content
- (4) Improve protein content

180. Sphincter of oddi is present at :

- (1) Junction of hepato-pancreatic duct and duodenum
- (2) Gastro-oesophageal junction
- (3) Junction of jejunum and duodenum
- (4) Ileo-caecal junction

181. During the process of gene amplification using PCR, if very high temperature is not maintained in the beginning, then which of the following steps of PCR will be affected first ?

- (1) Extension
- (2) Denaturation
- (3) Ligation
- (4) Annealing

182. The fruit fly has 8 chromosomes (2n) in each cell. During interphase of Mitosis if the number of chromosomes at G<sub>1</sub> phase is 8, what would be the number of chromosomes after S phase ?

- (1) 16
- (2) 4
- (3) 32
- (4) 8

183. Which of the following RNAs is not required for the synthesis of protein ?

- (1) tRNA
- (2) rRNA
- (3) siRNA
- (4) mRNA

184. Which of the following statements wrongly represents the nature of smooth muscle ?

- (1) They are involuntary muscles
- (2) Communication among the cells is performed by intercalated discs
- (3) These muscles are present in the wall of blood vessels
- (4) These muscle have no striations

185. If Adenine makes 30% of the DNA molecule, what will be the percentage of Thymine, Guanine and Cytosine in it ?

- (1) T : 20 ; G : 20 ; C : 30
- (2) T : 30 ; G : 20 ; C : 20
- (3) T : 20 ; G : 25 ; C : 25
- (4) T : 20 ; G : 30 ; C : 20

### Section - B (Biology : Zoology)

186. Which of these is not an important component of initiation of parturition in humans ?

- (1) Synthesis of prostaglandins
- (2) Release of Oxytocin
- (3) Release of Prolactin
- (4) Increase in estrogen and progesterone ratio

187. Match List - I with List - II.

List - I		List - II	
(a)	Filariasis	(i)	<i>Haemophilus influenzae</i>
(b)	Amoebiasis	(ii)	<i>Trichophyton</i>
(c)	Pneumonia	(iii)	<i>Wuchereria bancrofti</i>
(d)	Ringworm	(iv)	<i>Entamoeba histolytica</i>

Choose the **correct** answer from the options given below.

- |     |            |            |            |            |
|-----|------------|------------|------------|------------|
|     | <b>(a)</b> | <b>(b)</b> | <b>(c)</b> | <b>(d)</b> |
| (1) | (iii)      | (iv)       | (i)        | (ii)       |
| (2) | (i)        | (ii)       | (iv)       | (iii)      |
| (3) | (ii)       | (iii)      | (i)        | (iv)       |
| (4) | (iv)       | (i)        | (iii)      | (ii)       |

188. Following are the statements about prostomium of earthworm.

- (a) It serves as a covering for mouth.
- (b) It helps to open cracks in the soil into which it can crawl.
- (c) It is one of the sensory structures.
- (d) It is the first body segment.

Choose the **correct** answer from the options given below.

- (1) (a), (b) and (d) are correct
- (2) (a), (b), (c) and (d) are correct
- (3) (b) and (c) are correct
- (4) (a), (b) and (c) are correct

## 189. Assertion (A) :

A person goes to high altitude and experiences 'altitude sickness' with symptoms like breathing difficulty and heart palpitations.

## Reason (R) :

Due to low atmospheric pressure at high altitude, the body does not get sufficient oxygen.

In the light of the above statements, choose the **correct** answer from the options given below.

- (1) Both (A) and (R) are true but (R) is not the correct explanation of (A)
- (2) (A) is true but (R) is false
- (3) (A) is false but (R) is true
- (4) Both (A) and (R) are true and (R) is the correct explanation of (A)

## 190. Match List - I with List - II.

List - I		List - II	
(a)	Scapula	(i)	Cartilaginous joints
(b)	Cranium	(ii)	Flat bone
(c)	Sternum	(iii)	Fibrous joints
(d)	Vertebral column	(iv)	Triangular flat bone

Choose the **correct** answer from the options given below.

- |  |            |            |            |            |
|--|------------|------------|------------|------------|
|  | <b>(a)</b> | <b>(b)</b> | <b>(c)</b> | <b>(d)</b> |
|--|------------|------------|------------|------------|
- (1) (ii) (iii) (iv) (i)
  - (2) (iv) (ii) (iii) (i)
  - (3) (iv) (iii) (ii) (i)
  - (4) (i) (iii) (ii) (iv)

## 191. Statement I :

The codon 'AUG' codes for methionine and phenylalanine.

## Statement II :

'AAA' and 'AAG' both codons code for the amino acid lysine.

In the light of the above statements, choose the **correct** answer from the options given below.

- (1) Both Statement I and Statement II are false
- (2) Statement I is correct but Statement II is false
- (3) Statement I is incorrect but Statement II is true
- (4) Both Statement I and Statement II are true

## 192. Match List - I with List - II.

List - I		List - II	
(a)	Allen's Rule	(i)	Kangaroo rat
(b)	Physiological adaptation	(ii)	Desert lizard
(c)	Behavioural adaptation	(iii)	Marine fish at depth
(d)	Biochemical adaptation	(iv)	Polar seal

Choose the **correct** answer from the options given below.

- |  |            |            |            |            |
|--|------------|------------|------------|------------|
|  | <b>(a)</b> | <b>(b)</b> | <b>(c)</b> | <b>(d)</b> |
|--|------------|------------|------------|------------|
- (1) (iv) (i) (iii) (ii)
  - (2) (iv) (i) (ii) (iii)
  - (3) (iv) (iii) (ii) (i)
  - (4) (iv) (ii) (iii) (i)

## 193. During muscular contraction which of the following events occur ?

- (a) 'H' zone disappears
- (b) 'A' band widens
- (c) 'I' band reduces in width
- (d) Myosine hydrolyzes ATP, releasing the ADP and Pi
- (e) Z-lines attached to actins are pulled inwards

Choose the **correct** answer from the options given below.

- (1) (a), (b), (c), (d) only
- (2) (b), (c), (d), (e) only
- (3) (b), (d), (e), (a) only
- (4) (a), (c), (d), (e) only

194. Which of the following is **not** a step in Multiple Ovulation Embryo Transfer Technology (MOET) ?

- (1) Cow yields about 6-8 eggs at a time
- (2) Cow is fertilized by artificial insemination
- (3) Fertilized eggs are transferred to surrogate mothers at 8-32 cell stage
- (4) Cow is administered hormone having LH like activity for super ovulation

195. Match List - I with List - II.

List - I		List - II	
(a)	Adaptive radiation	(i)	Selection of resistant varieties due to excessive use of herbicides and pesticides
(b)	Convergent evolution	(ii)	Bones of forelimbs in Man and Whale
(c)	Divergent evolution	(iii)	Wings of Butterfly and Bird
(d)	Evolution by anthropogenic action	(iv)	Darwin Finches

Choose the **correct** answer from the options given below.

(a) (b) (c) (d)

- (1) (iii) (ii) (i) (iv)  
 (2) (ii) (i) (iv) (iii)  
 (3) (i) (iv) (iii) (ii)  
 (4) (iv) (iii) (ii) (i)

196. Following are the statements with reference to 'lipids'.

- (a) Lipids having only single bonds are called unsaturated fatty acids.  
 (b) Lecithin is a phospholipid.  
 (c) Trihydroxy propane is glycerol.  
 (d) Palmitic acid has 20 carbon atoms including carboxyl carbon.  
 (e) Arachidonic acid has 16 carbon atoms.

Choose the **correct** answer from the options given below.

- (1) (c) and (d) only  
 (2) (b) and (c) only  
 (3) (b) and (e) only  
 (4) (a) and (b) only

197. Which of the following secretes the hormone, relaxin, during the later phase of pregnancy ?

- (1) Corpus luteum  
 (2) Foetus  
 (3) Uterus  
 (4) Graafian follicle

198. The Adenosine deaminase deficiency results into :

- (1) Parkinson's disease  
 (2) Digestive disorder  
 (3) Addison's disease  
 (4) Dysfunction of Immune system

199. Which one of the following statements about Histones is **wrong** ?

- (1) The pH of histones is slightly acidic.  
 (2) Histones are rich in amino acids - Lysine and Arginine.  
 (3) Histones carry positive charge in the side chain.  
 (4) Histones are organized to form a unit of 8 molecules.

200. Identify the types of cell junctions that help to stop the leakage of the substances across a tissue and facilitation of communication with neighbouring cells via rapid transfer of ions and molecules.

- (1) Tight junctions and Gap junctions, respectively.  
 (2) Adhering junctions and Tight junctions, respectively.  
 (3) Adhering junctions and Gap junctions, respectively.  
 (4) Gap junctions and Adhering junctions, respectively.

- o o o -

**N1**

**26**

**Space For Rough Work**

**Space For Rough Work**

**N1**

**28**

**Space For Rough Work**



Test Booklet Code

GAJAH

No. :

01

This Booklet contains 28 pages.

Do not open this Test Booklet until you are asked to do so.

**Important Instructions :**

1. The Answer Sheet is inside this Test Booklet. When you are directed to open the Test Booklet, take out the Answer Sheet and fill in the particulars on OFFICE Copy carefully with **blue/black** ball point pen only.
2. The test is of **3 hours** duration and the Test Booklet contains **200** multiple-choice questions (four options with a single correct answer) from **Physics, Chemistry and Biology (Botany and Zoology)**. **50** questions in each subject are divided into **two Sections (A and B)** as per details given below :
  - (a) **Section A** shall consist of **35 (Thirty-five)** Questions in each subject (Question Nos – 1 to 35, 51 to 85, 101 to 135 and 151 to 185). All questions are compulsory.
  - (b) **Section B** shall consist of **15 (Fifteen)** questions in each subject (Question Nos – 36 to 50, 86 to 100, 136 to 150 and 186 to 200). In Section B, a candidate needs to **attempt any 10 (Ten)** questions out of **15 (Fifteen)** in each subject.

**Candidates are advised to read all 15 questions in each subject of Section B before they start attempting the question paper. In the event of a candidate attempting more than ten questions, the first ten questions answered by the candidate shall be evaluated.**
3. Each question carries **4** marks. For each correct response, the candidate will get **4** marks. For each incorrect response, **one** mark will be deducted from the total scores. **The maximum marks are 720.**
4. Use **Blue/Black Ball Point Pen only** for writing particulars on this page/markings responses on Answer Sheet.
5. Rough work is to be done in the space provided for this purpose in the Test Booklet only.
6. On completion of the test, the candidate **must hand over the Answer Sheet (ORIGINAL and OFFICE Copy) to the Invigilator** before leaving the Room/Hall. The candidates are allowed to take away this Test Booklet with them.
7. **The CODE for this Booklet is O1. Make sure that the CODE printed on the Original Copy of the Answer Sheet is the same as that on this Test Booklet.** In case of discrepancy, the candidate should immediately report the matter to the Invigilator for replacement of both the Test Booklet and the Answer Sheet.
8. The candidates should ensure that the Answer Sheet is not folded. Do not make any stray marks on the Answer Sheet. Do not write your Roll No. anywhere else except in the specified space in the Test Booklet/ Answer Sheet.
9. Use of white fluid for correction is **NOT** permissible on the Answer Sheet.
10. Each candidate must show on-demand his/her Admit Card to the Invigilator.
11. No candidate, without special permission of the centre Superintendent or Invigilator, would leave his/her seat.
12. The candidates should not leave the Examination Hall without handing over their Answer Sheet to the Invigilator on duty and sign (with time) the Attendance Sheet **twice**. **Cases, where a candidate has not signed the Attendance Sheet second time, will be deemed not to have handed over the Answer Sheet and dealt with as an Unfair Means case.**
13. Use of Electronic/Manual Calculator is prohibited.
14. The candidates are governed by all Rules and Regulations of the examination with regard to their conduct in the Examination Room/Hall. All cases of unfair means will be dealt with as per the Rules and Regulations of this examination.
15. **No part of the Test Booklet and Answer Sheet shall be detached under any circumstances.**
16. The candidates will write the Correct Test Booklet Code as given in the Test Booklet/Answer Sheet in the Attendance Sheet.

Name of the Candidate (in Capitals) : \_\_\_\_\_

Roll Number : in figures \_\_\_\_\_

: in words \_\_\_\_\_

Centre of Examination (in Capitals) : \_\_\_\_\_

Candidate's Signature : \_\_\_\_\_ Invigilator's Signature : \_\_\_\_\_

Facsimile signature stamp of  
Centre Superintendent : \_\_\_\_\_

**Section - A (Physics)**

1. A radioactive nucleus  ${}^A_ZX$  undergoes spontaneous decay in the sequence

${}^A_ZX \rightarrow {}_{Z-1}B \rightarrow {}_{Z-3}C \rightarrow {}_{Z-2}D$ , where Z is the atomic number of element X. The possible decay particles in the sequence are :

- (1)  $\beta^+$ ,  $\alpha$ ,  $\beta^-$
- (2)  $\beta^-$ ,  $\alpha$ ,  $\beta^+$
- (3)  $\alpha$ ,  $\beta^-$ ,  $\beta^+$
- (4)  $\alpha$ ,  $\beta^+$ ,  $\beta^-$

2. Polar molecules are the molecules :

- (1) acquire a dipole moment only when magnetic field is absent.
- (2) having a permanent electric dipole moment.
- (3) having zero dipole moment.
- (4) acquire a dipole moment only in the presence of electric field due to displacement of charges.

3. The effective resistance of a parallel connection that consists of four wires of equal length, equal area of cross-section and same material is  $0.25 \Omega$ . What will be the effective resistance if they are connected in series ?

- (1)  $1 \Omega$
- (2)  $4 \Omega$
- (3)  $0.25 \Omega$
- (4)  $0.5 \Omega$

4. **Column - I** gives certain physical terms associated with flow of current through a metallic conductor. **Column - II** gives some mathematical relations involving electrical quantities. Match **Column - I** and **Column - II** with appropriate relations.

Column - I	Column - II
(A) Drift Velocity	(P) $\frac{m}{ne^2\rho}$
(B) Electrical Resistivity	(Q) $nev_d$
(C) Relaxation Period	(R) $\frac{eE}{m}\tau$
(D) Current Density	(S) $\frac{E}{J}$

- (1) (A)-(R), (B)-(P), (C)-(S), (D)-(Q)
- (2) (A)-(R), (B)-(Q), (C)-(S), (D)-(P)
- (3) (A)-(R), (B)-(S), (C)-(P), (D)-(Q)
- (4) (A)-(R), (B)-(S), (C)-(Q), (D)-(P)

5. The equivalent capacitance of the combination shown in the figure is :

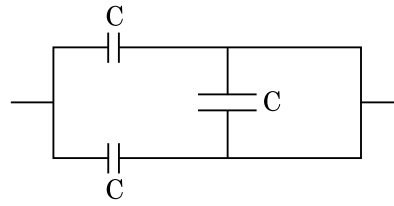

- (1)  $C/2$
- (2)  $3C/2$
- (3)  $3C$
- (4)  $2C$

6. In a potentiometer circuit a cell of EMF 1.5 V gives balance point at 36 cm length of wire. If another cell of EMF 2.5 V replaces the first cell, then at what length of the wire, the balance point occurs ?

- (1) 64 cm
- (2) 62 cm
- (3) 60 cm
- (4) 21.6 cm

7. The escape velocity from the Earth's surface is  $v$ . The escape velocity from the surface of another planet having a radius, four times that of Earth and same mass density is :

- (1)  $3v$
- (2)  $4v$
- (3)  $v$
- (4)  $2v$

8. A cup of coffee cools from  $90^\circ\text{C}$  to  $80^\circ\text{C}$  in  $t$  minutes, when the room temperature is  $20^\circ\text{C}$ . The time taken by a similar cup of coffee to cool from  $80^\circ\text{C}$  to  $60^\circ\text{C}$  at a room temperature same at  $20^\circ\text{C}$  is :

- (1)  $\frac{10}{13}t$
- (2)  $\frac{5}{13}t$
- (3)  $\frac{13}{10}t$
- (4)  $\frac{13}{5}t$

9. A capacitor of capacitance 'C', is connected across an ac source of voltage V, given by  $V = V_0 \sin \omega t$

The displacement current between the plates of the capacitor, would then be given by :

- (1)  $I_d = \frac{V_0}{\omega C} \sin \omega t$
- (2)  $I_d = V_0 \omega C \sin \omega t$
- (3)  $I_d = V_0 \omega C \cos \omega t$
- (4)  $I_d = \frac{V_0}{\omega C} \cos \omega t$

10. A small block slides down on a smooth inclined plane, starting from rest at time  $t=0$ . Let  $S_n$  be the distance travelled by the block in the interval  $t=n-1$  to  $t=n$ . Then, the ratio  $\frac{S_n}{S_{n+1}}$  is :
- (1)  $\frac{2n+1}{2n-1}$
  - (2)  $\frac{2n}{2n-1}$
  - (3)  $\frac{2n-1}{2n}$
  - (4)  $\frac{2n-1}{2n+1}$
11. If force [F], acceleration [A] and time [T] are chosen as the fundamental physical quantities. Find the dimensions of energy.
- (1) [F] [A] [T<sup>-1</sup>]
  - (2) [F] [A<sup>-1</sup>] [T]
  - (3) [F] [A] [T]
  - (4) [F] [A] [T<sup>2</sup>]
12. For a plane electromagnetic wave propagating in  $x$ -direction, which one of the following combination gives the correct possible directions for electric field (E) and magnetic field (B) respectively ?
- (1)  $\hat{j} + \hat{k}, -\hat{j} - \hat{k}$
  - (2)  $-\hat{j} + \hat{k}, -\hat{j} + \hat{k}$
  - (3)  $\hat{j} + \hat{k}, \hat{j} + \hat{k}$
  - (4)  $-\hat{j} + \hat{k}, -\hat{j} - \hat{k}$
13. A spring is stretched by 5 cm by a force 10 N. The time period of the oscillations when a mass of 2 kg is suspended by it is :
- (1) 3.14 s
  - (2) 0.628 s
  - (3) 0.0628 s
  - (4) 6.28 s
14. A particle is released from height S from the surface of the Earth. At a certain height its kinetic energy is three times its potential energy. The height from the surface of earth and the speed of the particle at that instant are respectively :
- (1)  $\frac{S}{2}, \frac{\sqrt{3gS}}{2}$
  - (2)  $\frac{S}{4}, \sqrt{\frac{3gS}{2}}$
  - (3)  $\frac{S}{4}, \frac{3gS}{2}$
  - (4)  $\frac{S}{4}, \frac{\sqrt{3gS}}{2}$
15. A lens of large focal length and large aperture is best suited as an objective of an astronomical telescope since :
- (1) a large aperture contributes to the quality and visibility of the images.
  - (2) a large area of the objective ensures better light gathering power.
  - (3) a large aperture provides a better resolution.
  - (4) all of the above.
16. Two charged spherical conductors of radius  $R_1$  and  $R_2$  are connected by a wire. Then the ratio of surface charge densities of the spheres ( $\sigma_1/\sigma_2$ ) is :
- (1)  $\sqrt{\left(\frac{R_1}{R_2}\right)}$
  - (2)  $\frac{R_1^2}{R_2^2}$
  - (3)  $\frac{R_1}{R_2}$
  - (4)  $\frac{R_2}{R_1}$
17. A convex lens 'A' of focal length 20 cm and a concave lens 'B' of focal length 5 cm are kept along the same axis with a distance 'd' between them. If a parallel beam of light falling on 'A' leaves 'B' as a parallel beam, then the distance 'd' in cm will be :
- (1) 50
  - (2) 30
  - (3) 25
  - (4) 15

18. An infinitely long straight conductor carries a current of 5 A as shown. An electron is moving with a speed of  $10^5$  m/s parallel to the conductor. The perpendicular distance between the electron and the conductor is 20 cm at an instant. Calculate the magnitude of the force experienced by the electron at that instant.

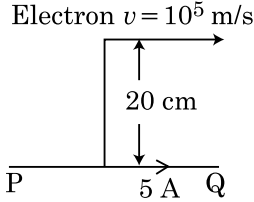

- (1)  $4\pi \times 10^{-20}$  N  
 (2)  $8 \times 10^{-20}$  N  
 (3)  $4 \times 10^{-20}$  N  
 (4)  $8\pi \times 10^{-20}$  N
19. If E and G respectively denote energy and gravitational constant, then  $\frac{E}{G}$  has the dimensions of :
- (1)  $[M] [L^0] [T^0]$   
 (2)  $[M^2] [L^{-2}] [T^{-1}]$   
 (3)  $[M^2] [L^{-1}] [T^0]$   
 (4)  $[M] [L^{-1}] [T^{-1}]$
20. The velocity of a small ball of mass M and density d, when dropped in a container filled with glycerine becomes constant after some time. If the density of glycerine is  $\frac{d}{2}$ , then the viscous force acting on the ball will be  $\frac{2}{3}$  :
- (1)  $\frac{3}{2}Mg$   
 (2)  $2Mg$   
 (3)  $\frac{Mg}{2}$   
 (4)  $Mg$
21. The electron concentration in an n-type semiconductor is the same as hole concentration in a p-type semiconductor. An external field (electric) is applied across each of them. Compare the currents in them.
- (1) current in n-type > current in p-type.  
 (2) No current will flow in p-type, current will only flow in n-type.  
 (3) current in n-type = current in p-type.  
 (4) current in p-type > current in n-type.

22. A thick current carrying cable of radius 'R' carries current 'I' uniformly distributed across its cross-section. The variation of magnetic field B(r) due to the cable with the distance 'r' from the axis of the cable is represented by :

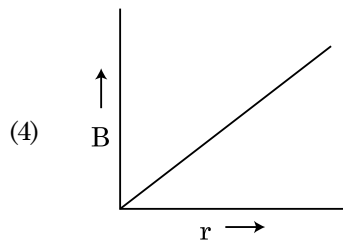
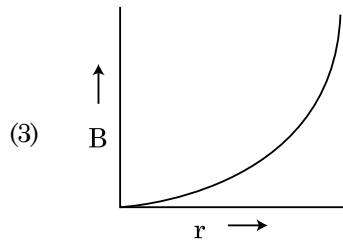
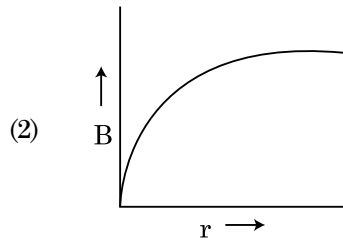
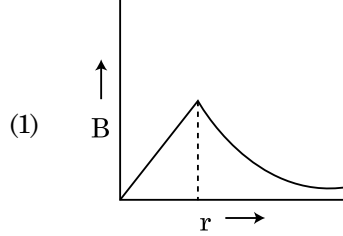

23. A screw gauge gives the following readings when used to measure the diameter of a wire  
 Main scale reading : 0 mm  
 Circular scale reading : 52 divisions  
 Given that 1 mm on main scale corresponds to 100 divisions on the circular scale. The diameter of the wire from the above data is :
- (1) 0.26 cm  
 (2) 0.052 cm  
 (3) 0.52 cm  
 (4) 0.026 cm
24. The number of photons per second on an average emitted by the source of monochromatic light of wavelength 600 nm, when it delivers the power of  $3.3 \times 10^{-3}$  watt will be : ( $h = 6.6 \times 10^{-34}$  Js)
- (1)  $10^{16}$   
 (2)  $10^{15}$   
 (3)  $10^{18}$   
 (4)  $10^{17}$

25. Water falls from a height of 60 m at the rate of 15 kg/s to operate a turbine. The losses due to frictional force are 10% of the input energy. How much power is generated by the turbine ?

$$(g = 10 \text{ m/s}^2)$$

- (1) 12.3 kW  
 (2) 7.0 kW  
 (3) 10.2 kW  
 (4) 8.1 kW

26. An electromagnetic wave of wavelength ' $\lambda$ ' is incident on a photosensitive surface of negligible work function. If ' $m$ ' mass is of photoelectron emitted from the surface has de-Broglie wavelength  $\lambda_d$ , then :

(1)  $\lambda = \left(\frac{2mc}{h}\right)\lambda_d^2$

(2)  $\lambda = \left(\frac{2h}{mc}\right)\lambda_d^2$

(3)  $\lambda = \left(\frac{2m}{hc}\right)\lambda_d^2$

(4)  $\lambda_d = \left(\frac{2mc}{h}\right)\lambda^2$

27. Match **Column - I** and **Column - II** and choose the **correct** match from the given choices.

Column - I	Column - II
(A) Root mean square speed of gas molecules	(P) $\frac{1}{3}nm\bar{v}^2$
(B) Pressure exerted by ideal gas	(Q) $\sqrt{\frac{3RT}{M}}$
(C) Average kinetic energy of a molecule	(R) $\frac{5}{2}RT$
(D) Total internal energy of 1 mole of a diatomic gas	(S) $\frac{3}{2}k_B T$

(1) (A) - (Q), (B) - (P), (C) - (S), (D) - (R)  
 (2) (A) - (R), (B) - (Q), (C) - (P), (D) - (S)  
 (3) (A) - (R), (B) - (P), (C) - (S), (D) - (Q)  
 (4) (A) - (Q), (B) - (R), (C) - (S), (D) - (P)

28. A nucleus with mass number 240 breaks into two fragments each of mass number 120, the binding energy per nucleon of unfragmented nuclei is 7.6 MeV while that of fragments is 8.5 MeV. The total gain in the Binding Energy in the process is :

- (1) 804 MeV  
 (2) 216 MeV  
 (3) 0.9 MeV  
 (4) 9.4 MeV

29. A parallel plate capacitor has a uniform electric field ' $\vec{E}$ ' in the space between the plates. If the distance between the plates is ' $d$ ' and the area of each plate is ' $A$ ', the energy stored in the capacitor is : ( $\epsilon_0$  = permittivity of free space)

(1)  $\frac{1}{2}\epsilon_0 E^2 Ad$

(2)  $\frac{E^2 Ad}{\epsilon_0}$

(3)  $\frac{1}{2}\epsilon_0 E^2$

(4)  $\epsilon_0 EAd$

30. Find the value of the angle of emergence from the prism. Refractive index of the glass is  $\sqrt{3}$ .

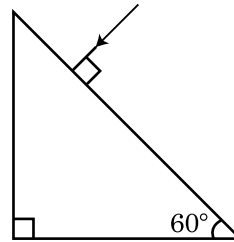

- (1) 45°  
 (2) 90°  
 (3) 60°  
 (4) 30°

31. A dipole is placed in an electric field as shown. In which direction will it move ?

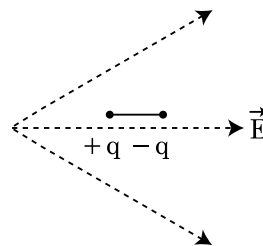

- (1) towards the left as its potential energy will decrease.  
 (2) towards the right as its potential energy will increase.  
 (3) towards the left as its potential energy will increase.  
 (4) towards the right as its potential energy will decrease.

32. Consider the following statements (A) and (B) and identify the correct answer.

- (A) A zener diode is connected in reverse bias, when used as a voltage regulator.  
 (B) The potential barrier of p-n junction lies between 0.1 V to 0.3 V.
- (1) (A) is correct and (B) is incorrect.  
 (2) (A) is incorrect but (B) is correct.  
 (3) (A) and (B) both are correct.  
 (4) (A) and (B) both are incorrect.

33. The half-life of a radioactive nuclide is 100 hours. The fraction of original activity that will remain after 150 hours would be :

- (1)  $\frac{2}{3}$   
 (2)  $\frac{2}{3\sqrt{2}}$   
 (3)  $\frac{1}{2}$   
 (4)  $\frac{1}{2\sqrt{2}}$

34. An inductor of inductance L, a capacitor of capacitance C and a resistor of resistance 'R' are connected in series to an ac source of potential difference 'V' volts as shown in figure.

Potential difference across L, C and R is 40 V, 10 V and 40 V, respectively. The amplitude of current flowing through LCR series circuit is  $10\sqrt{2}$  A. The impedance of the circuit is :

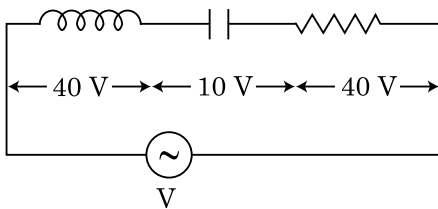

- (1)  $4 \Omega$   
 (2)  $5 \Omega$   
 (3)  $4\sqrt{2} \Omega$   
 (4)  $5/\sqrt{2} \Omega$

35. A body is executing simple harmonic motion with frequency 'n', the frequency of its potential energy is :

- (1)  $3n$   
 (2)  $4n$   
 (3)  $n$   
 (4)  $2n$

### Section - B (Physics)

36. From a circular ring of mass 'M' and radius 'R' an arc corresponding to a  $90^\circ$  sector is removed. The moment of inertia of the remaining part of the ring about an axis passing through the centre of the ring and perpendicular to the plane of the ring is 'K' times ' $MR^2$ '. Then the value of 'K' is :

- (1)  $\frac{1}{4}$   
 (2)  $\frac{1}{8}$   
 (3)  $\frac{3}{4}$   
 (4)  $\frac{7}{8}$

37. A series LCR circuit containing 5.0 H inductor,  $80 \mu\text{F}$  capacitor and  $40 \Omega$  resistor is connected to 230 V variable frequency ac source. The angular frequencies of the source at which power transferred to the circuit is half the power at the resonant angular frequency are likely to be :

- (1) 46 rad/s and 54 rad/s  
 (2) 42 rad/s and 58 rad/s  
 (3) 25 rad/s and 75 rad/s  
 (4) 50 rad/s and 25 rad/s

38. A uniform conducting wire of length  $12a$  and resistance 'R' is wound up as a current carrying coil in the shape of,

- (i) an equilateral triangle of side 'a'.  
 (ii) a square of side 'a'.

The magnetic dipole moments of the coil in each case respectively are :

- (1)  $3 Ia^2$  and  $4 Ia^2$   
 (2)  $4 Ia^2$  and  $3 Ia^2$   
 (3)  $\sqrt{3} Ia^2$  and  $3 Ia^2$   
 (4)  $3 Ia^2$  and  $Ia^2$

39. A step down transformer connected to an ac mains supply of 220 V is made to operate at 11 V, 44 W lamp. Ignoring power losses in the transformer, what is the current in the primary circuit ?

- (1) 2 A  
 (2) 4 A  
 (3) 0.2 A  
 (4) 0.4 A

40. Twenty seven drops of same size are charged at 220 V each. They combine to form a bigger drop. Calculate the potential of the bigger drop.

- (1) 1520 V
- (2) 1980 V
- (3) 660 V
- (4) 1320 V

41. Two conducting circular loops of radii  $R_1$  and  $R_2$  are placed in the same plane with their centres coinciding. If  $R_1 \gg R_2$ , the mutual inductance  $M$  between them will be directly proportional to :

- (1)  $\frac{R_1^2}{R_2}$
- (2)  $\frac{R_2^2}{R_1}$
- (3)  $\frac{R_1}{R_2}$
- (4)  $\frac{R_2}{R_1}$

42. A particle of mass 'm' is projected with a velocity  $v = kV_e$  ( $k < 1$ ) from the surface of the earth.

( $V_e$  = escape velocity)

The maximum height above the surface reached by the particle is :

- (1)  $\frac{R^2 k}{1+k}$
- (2)  $\frac{Rk^2}{1-k^2}$
- (3)  $R \left( \frac{k}{1-k} \right)^2$
- (4)  $R \left( \frac{k}{1+k} \right)^2$

43. A uniform rod of length 200 cm and mass 500 g is balanced on a wedge placed at 40 cm mark. A mass of 2 kg is suspended from the rod at 20 cm and another unknown mass 'm' is suspended from the rod at 160 cm as shown in the figure. Find the value of 'm' such that the rod is in equilibrium. ( $g = 10 \text{ m/s}^2$ )

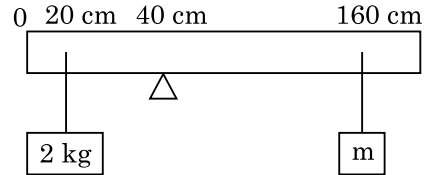

- (1)  $\frac{1}{6}$  kg
  - (2)  $\frac{1}{12}$  kg
  - (3)  $\frac{1}{2}$  kg
  - (4)  $\frac{1}{3}$  kg
44. A ball of mass 0.15 kg is dropped from a height 10 m, strikes the ground and rebounds to the same height. The magnitude of impulse imparted to the ball is ( $g = 10 \text{ m/s}^2$ ) nearly :
- (1) 2.1 kg m/s
  - (2) 1.4 kg m/s
  - (3) 0 kg m/s
  - (4) 4.2 kg m/s
45. A particle moving in a circle of radius  $R$  with a uniform speed takes a time  $T$  to complete one revolution.

If this particle were projected with the same speed at an angle ' $\theta$ ' to the horizontal, the maximum height attained by it equals  $4R$ . The angle of projection,  $\theta$ , is then given by :

- (1)  $\theta = \sin^{-1} \left( \frac{\pi^2 R}{gT^2} \right)^{1/2}$
- (2)  $\theta = \sin^{-1} \left( \frac{2gT^2}{\pi^2 R} \right)^{1/2}$
- (3)  $\theta = \cos^{-1} \left( \frac{gT^2}{\pi^2 R} \right)^{1/2}$
- (4)  $\theta = \cos^{-1} \left( \frac{\pi^2 R}{gT^2} \right)^{1/2}$

46. For the given circuit, the input digital signals are applied at the terminals A, B and C. What would be the output at the terminal y?

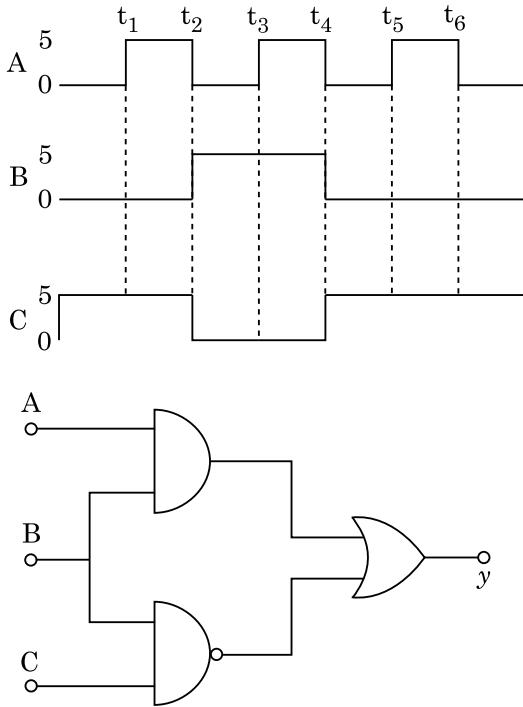

- (1)
- (2)
- (3)
- (4)

47. In the product

$$\vec{F} = q(\vec{v} \times \vec{B})$$

$$= q \vec{v} \times (B_1 \hat{i} + B_2 \hat{j} + B_3 \hat{k})$$

For  $q = 1$  and  $\vec{v} = 2\hat{i} + 4\hat{j} + 6\hat{k}$  and

$$\vec{F} = 4\hat{i} - 20\hat{j} + 12\hat{k}$$

What will be the complete expression for  $\vec{B}$ ?

- (1)  $8\hat{i} + 8\hat{j} - 6\hat{k}$
- (2)  $6\hat{i} + 6\hat{j} - 8\hat{k}$
- (3)  $-8\hat{i} - 8\hat{j} - 6\hat{k}$
- (4)  $-6\hat{i} - 6\hat{j} - 8\hat{k}$

48. A car starts from rest and accelerates at  $5 \text{ m/s}^2$ . At  $t = 4 \text{ s}$ , a ball is dropped out of a window by a person sitting in the car. What is the velocity and acceleration of the ball at  $t = 6 \text{ s}$ ? (Take  $g = 10 \text{ m/s}^2$ )

- (1)  $20\sqrt{2} \text{ m/s}, 0$
- (2)  $20\sqrt{2} \text{ m/s}, 10 \text{ m/s}^2$
- (3)  $20 \text{ m/s}, 5 \text{ m/s}^2$
- (4)  $20 \text{ m/s}, 0$

49. Three resistors having resistances  $r_1, r_2$  and  $r_3$  are connected as shown in the given circuit. The ratio  $\frac{i_3}{i_1}$  of currents in terms of resistances used in the circuit is:

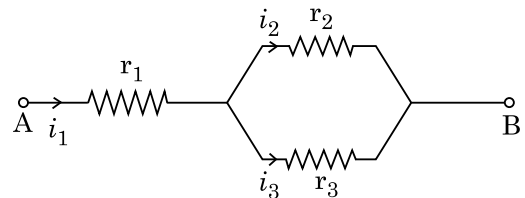

- (1)  $\frac{r_1}{r_1 + r_2}$
- (2)  $\frac{r_2}{r_1 + r_3}$
- (3)  $\frac{r_1}{r_2 + r_3}$
- (4)  $\frac{r_2}{r_2 + r_3}$

50. A point object is placed at a distance of 60 cm from a convex lens of focal length 30 cm. If a plane mirror were put perpendicular to the principal axis of the lens and at a distance of 40 cm from it, the final image would be formed at a distance of:

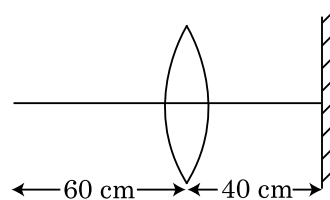

- (1) 30 cm from the plane mirror, it would be a virtual image.
- (2) 20 cm from the plane mirror, it would be a virtual image.
- (3) 20 cm from the lens, it would be a real image.
- (4) 30 cm from the lens, it would be a real image.



### Section - A (Chemistry)

51.  $\text{BF}_3$  is planar and electron deficient compound. Hybridization and number of electrons around the central atom, respectively are :
- (1)  $sp^2$  and 6
  - (2)  $sp^2$  and 8
  - (3)  $sp^3$  and 4
  - (4)  $sp^3$  and 6
52. Which of the following reactions is the metal displacement reaction? Choose the right option.
- (1)  $\text{Fe} + 2\text{HCl} \rightarrow \text{FeCl}_2 + \text{H}_2 \uparrow$
  - (2)  $2\text{Pb}(\text{NO}_3)_2 \rightarrow 2\text{PbO} + 4\text{NO}_2 + \text{O}_2 \uparrow$
  - (3)  $2\text{KClO}_3 \xrightarrow{\Delta} 2\text{KCl} + 3\text{O}_2$
  - (4)  $\text{Cr}_2\text{O}_3 + 2\text{Al} \xrightarrow{\Delta} \text{Al}_2\text{O}_3 + 2\text{Cr}$
53. The compound which shows metamerism is :
- (1)  $\text{C}_3\text{H}_6\text{O}$
  - (2)  $\text{C}_4\text{H}_{10}\text{O}$
  - (3)  $\text{C}_5\text{H}_{12}$
  - (4)  $\text{C}_3\text{H}_8\text{O}$
54. The  $pK_b$  of dimethylamine and  $pK_a$  of acetic acid are 3.27 and 4.77 respectively at T (K). The correct option for the pH of dimethylammonium acetate solution is :
- (1) 7.75
  - (2) 6.25
  - (3) 8.50
  - (4) 5.50
55. The structures of beryllium chloride in solid state and vapour phase, are :
- (1) Dimer and Linear, respectively
  - (2) Chain in both
  - (3) Chain and dimer, respectively
  - (4) Linear in both
56. Zr ( $Z = 40$ ) and Hf ( $Z = 72$ ) have similar atomic and ionic radii because of :
- (1) lanthanoid contraction
  - (2) having similar chemical properties
  - (3) belonging to same group
  - (4) diagonal relationship
57. A particular station of All India Radio, New Delhi, broadcasts on a frequency of 1,368 kHz (kilohertz). The wavelength of the electromagnetic radiation emitted by the transmitter is : [speed of light,  $c = 3.0 \times 10^8 \text{ ms}^{-1}$ ]
- (1) 2192 m
  - (2) 21.92 cm
  - (3) 219.3 m
  - (4) 219.2 m
58. An organic compound contains 78% (by wt.) carbon and remaining percentage of hydrogen. The right option for the empirical formula of this compound is : [Atomic wt. of C is 12, H is 1]
- (1)  $\text{CH}_3$
  - (2)  $\text{CH}_4$
  - (3) CH
  - (4)  $\text{CH}_2$
59. Ethylene diaminetetraacetate (EDTA) ion is :
- (1) Bidentate ligand with two "N" donor atoms
  - (2) Tridentate ligand with three "N" donor atoms
  - (3) Hexadentate ligand with four "O" and two "N" donor atoms
  - (4) Unidentate ligand
60. Among the following alkaline earth metal halides, one which is covalent and soluble in organic solvents is :
- (1) Magnesium chloride
  - (2) Beryllium chloride
  - (3) Calcium chloride
  - (4) Strontium chloride
61. The right option for the statement "Tyndall effect is exhibited by", is :
- (1) Starch solution
  - (2) Urea solution
  - (3) NaCl solution
  - (4) Glucose solution
62. The molar conductance of NaCl, HCl and  $\text{CH}_3\text{COONa}$  at infinite dilution are 126.45, 426.16 and  $91.0 \text{ S cm}^2 \text{ mol}^{-1}$  respectively. The molar conductance of  $\text{CH}_3\text{COOH}$  at infinite dilution is. Choose the right option for your answer.
- (1)  $698.28 \text{ S cm}^2 \text{ mol}^{-1}$
  - (2)  $540.48 \text{ S cm}^2 \text{ mol}^{-1}$
  - (3)  $201.28 \text{ S cm}^2 \text{ mol}^{-1}$
  - (4)  $390.71 \text{ S cm}^2 \text{ mol}^{-1}$

63. The correct structure of 2,6-Dimethyl-dec-4-ene is :

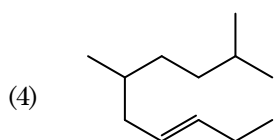
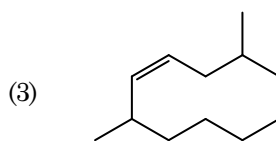
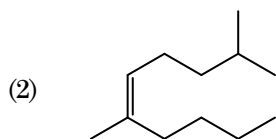
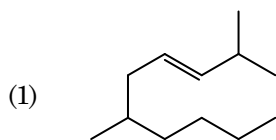

64. The correct option for the number of body centred unit cells in all 14 types of Bravais lattice unit cells is :

- (1) 2  
(2) 3  
(3) 7  
(4) 5

65. Which one of the following polymers is prepared by addition polymerisation ?

- (1) Novolac  
(2) Dacron  
(3) Teflon  
(4) Nylon-66

66. What is the IUPAC name of the organic compound formed in the following chemical reaction ?

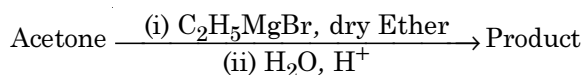

- (1) pentan-3-ol  
(2) 2-methyl butan-2-ol  
(3) 2-methyl propan-2-ol  
(4) pentan-2-ol

67. Match List - I with List - II.

List - I		List - II	
(a)	$\text{PCl}_5$	(i)	Square pyramidal
(b)	$\text{SF}_6$	(ii)	Trigonal planar
(c)	$\text{BrF}_5$	(iii)	Octahedral
(d)	$\text{BF}_3$	(iv)	Trigonal bipyramidal

Choose the **correct** answer from the options given below.

- (1) (a)-(iii), (b)-(i), (c)-(iv), (d)-(ii)  
(2) (a)-(iv), (b)-(iii), (c)-(ii), (d)-(i)  
(3) (a)-(iv), (b)-(iii), (c)-(i), (d)-(ii)  
(4) (a)-(ii), (b)-(iii), (c)-(iv), (d)-(i)

68. The **incorrect** statement among the following is :

- (1) Lanthanoids are good conductors of heat and electricity.  
(2) Actinoids are highly reactive metals, especially when finely divided.  
(3) Actinoid contraction is greater for element to element than Lanthanoid contraction.  
(4) Most of the trivalent Lanthanoid ions are colorless in the solid state.

69. Dihedral angle of least stable conformer of ethane is :

- (1)  $60^\circ$   
(2)  $0^\circ$   
(3)  $120^\circ$   
(4)  $180^\circ$

70. Choose the correct option for graphical representation of Boyle's law, which shows a graph of pressure vs. volume of a gas at different temperatures :

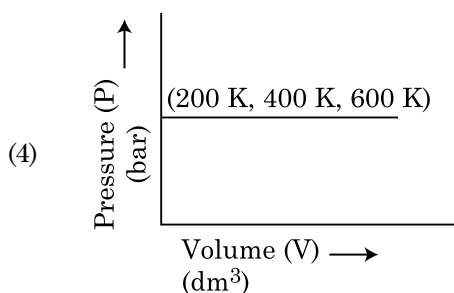
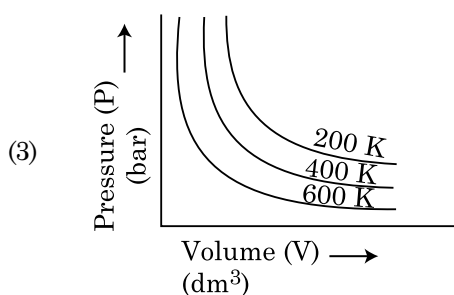
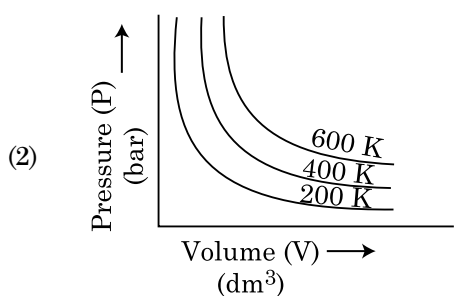
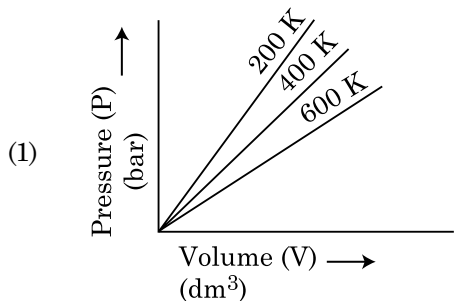

71. The correct sequence of bond enthalpy of 'C-X' bond is :
- (1)  $\text{CH}_3-\text{F} < \text{CH}_3-\text{Cl} > \text{CH}_3-\text{Br} > \text{CH}_3-\text{I}$
  - (2)  $\text{CH}_3-\text{Cl} > \text{CH}_3-\text{F} > \text{CH}_3-\text{Br} > \text{CH}_3-\text{I}$
  - (3)  $\text{CH}_3-\text{F} < \text{CH}_3-\text{Cl} < \text{CH}_3-\text{Br} < \text{CH}_3-\text{I}$
  - (4)  $\text{CH}_3-\text{F} > \text{CH}_3-\text{Cl} > \text{CH}_3-\text{Br} > \text{CH}_3-\text{I}$
72. Tritium, a radioactive isotope of hydrogen, emits which of the following particles ?
- (1) Gamma ( $\gamma$ )
  - (2) Neutron ( $n$ )
  - (3) Beta ( $\beta^-$ )
  - (4) Alpha ( $\alpha$ )

73. **Statement I :**

Acid strength increases in the order given as  $\text{HF} \ll \text{HCl} \ll \text{HBr} \ll \text{HI}$ .

**Statement II :**

As the size of the elements F, Cl, Br, I increases down the group, the bond strength of HF, HCl, HBr and HI decreases and so the acid strength increases.

In the light of the above statements, choose the **correct** answer from the options given below.

- (1) **Statement I** is correct but **Statement II** is false.
- (2) **Statement I** is incorrect but **Statement II** is true.
- (3) Both **Statement I** and **Statement II** are true.
- (4) Both **Statement I** and **Statement II** are false.

74. Given below are two statements :

**Statement I :**

Aspirin and Paracetamol belong to the class of narcotic analgesics.

**Statement II :**

Morphine and Heroin are non-narcotic analgesics.

In the light of the above statements, choose the **correct** answer from the options given below.

- (1) **Statement I** is correct but **Statement II** is false.
- (2) **Statement I** is incorrect but **Statement II** is true.
- (3) Both **Statement I** and **Statement II** are true.
- (4) Both **Statement I** and **Statement II** are false.

75. Which one among the following is the correct option for right relationship between  $C_p$  and  $C_v$  for one mole of ideal gas ?

- (1)  $C_p = RC_v$
- (2)  $C_v = RC_p$
- (3)  $C_p + C_v = R$
- (4)  $C_p - C_v = R$

76. The maximum temperature that can be achieved in blast furnace is :

- (1) upto 1900 K
- (2) upto 5000 K
- (3) upto 1200 K
- (4) upto 2200 K

77. For a reaction  $A \rightarrow B$ , enthalpy of reaction is  $-4.2 \text{ kJ mol}^{-1}$  and enthalpy of activation is  $9.6 \text{ kJ mol}^{-1}$ . The correct potential energy profile for the reaction is shown in option.

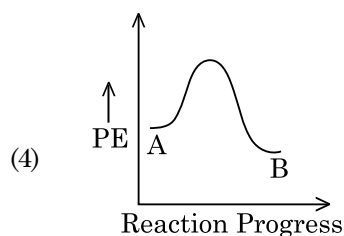
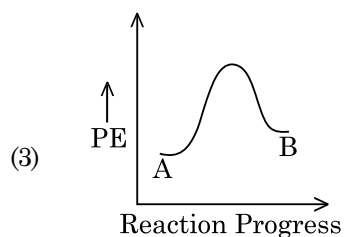
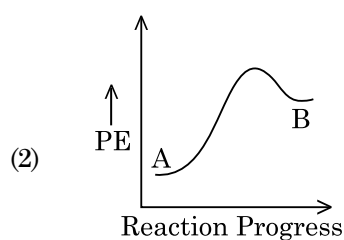
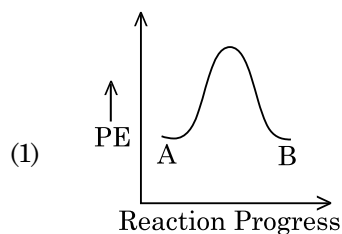

78. Which one of the following methods can be used to obtain highly pure metal which is liquid at room temperature?

- (1) Distillation
- (2) Zone refining
- (3) Electrolysis
- (4) Chromatography

79. The RBC deficiency is deficiency disease of:

- (1) Vitamin B<sub>1</sub>
- (2) Vitamin B<sub>2</sub>
- (3) Vitamin B<sub>12</sub>
- (4) Vitamin B<sub>6</sub>

80. The major product of the following chemical reaction is:

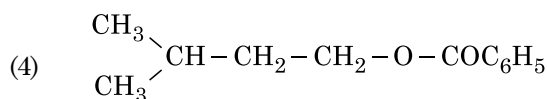
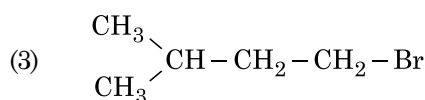
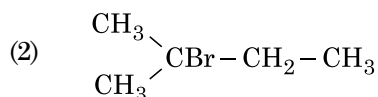
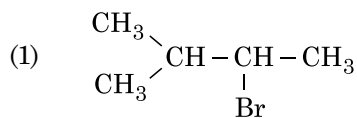
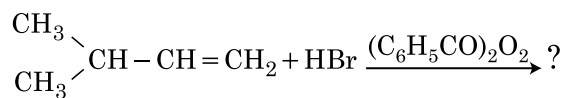

81. Right option for the number of tetrahedral and octahedral voids in hexagonal primitive unit cell are:

- (1) 2, 1
- (2) 12, 6
- (3) 8, 4
- (4) 6, 12

82. Noble gases are named because of their inertness towards reactivity. Identify an **incorrect** statement about them.

- (1) Noble gases have weak dispersion forces.
- (2) Noble gases have large positive values of electron gain enthalpy.
- (3) Noble gases are sparingly soluble in water.
- (4) Noble gases have very high melting and boiling points.

83. The major product formed in dehydrohalogenation reaction of 2-Bromo pentane is Pent-2-ene. This product formation is based on?

- (1) Hofmann Rule
- (2) Huckel's Rule
- (3) Saytzeff's Rule
- (4) Hund's Rule

84. Identify the compound that will react with Hinsberg's reagent to give a solid which dissolves in alkali.

- (1)
- (2)
- (3)
- (4)

85. The following solutions were prepared by dissolving 10 g of glucose ( $C_6H_{12}O_6$ ) in 250 ml of water ( $P_1$ ), 10 g of urea ( $CH_4N_2O$ ) in 250 ml of water ( $P_2$ ) and 10 g of sucrose ( $C_{12}H_{22}O_{11}$ ) in 250 ml of water ( $P_3$ ). The right option for the decreasing order of osmotic pressure of these solutions is :

- (1)  $P_2 > P_3 > P_1$
- (2)  $P_3 > P_1 > P_2$
- (3)  $P_2 > P_1 > P_3$
- (4)  $P_1 > P_2 > P_3$

### Section - B (Chemistry)

86. Match List - I with List - II.

- | List - I  | List - II                   |
|---|-----------------------------|
| (a) $2SO_2(g) + O_2(g) \rightarrow 2SO_3(g)$            | (i) Acid rain               |
| (b) $HOCl(g) \xrightarrow{h\nu} \dot{O}H + \dot{Cl}$    | (ii) Smog                   |
| (c) $CaCO_3 + H_2SO_4 \rightarrow CaSO_4 + H_2O + CO_2$ | (iii) Ozone depletion       |
| (d) $NO_2(g) \xrightarrow{h\nu} NO(g) + O(g)$           | (iv) Tropospheric pollution |

Choose the **correct** answer from the options given below.

- (1) (a)-(iv), (b)-(iii), (c)-(i), (d)-(ii)
- (2) (a)-(iii), (b)-(ii), (c)-(iv), (d)-(i)
- (3) (a)-(i), (b)-(ii), (c)-(iii), (d)-(iv)
- (4) (a)-(ii), (b)-(iii), (c)-(iv), (d)-(i)

87. The intermediate compound 'X' in the following chemical reaction is :

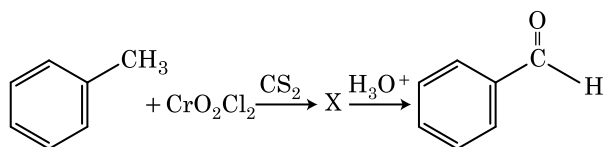

- (1)
- (2)
- (3)
- (4)

88. Match List - I with List - II.

- | List - I  | List - II                          |
|---|------------------------------------|
| (a) $\xrightarrow[\text{CuCl}]{\text{CO, HCl, Anhyd. AlCl}_3}$                      | (i) Hell-Volhard-Zelinsky reaction |
| (b) $R-\overset{\text{O}}{\parallel}{C}-CH_3 + NaOX \longrightarrow$                | (ii) Gattermann-Koch reaction      |
| (c) $R-CH_2-OH + R'COOH \xrightarrow{\text{Conc. H}_2\text{SO}_4}$                  | (iii) Haloform reaction            |
| (d) $R-CH_2COOH \xrightarrow[\text{(ii) H}_2\text{O}]{\text{(i) X}_2/\text{Red P}}$ | (iv) Esterification                |

Choose the **correct** answer from the options given below.

- (1) (a)-(i), (b)-(iv), (c)-(iii), (d)-(ii)
- (2) (a)-(ii), (b)-(iii), (c)-(iv), (d)-(i)
- (3) (a)-(iv), (b)-(i), (c)-(ii), (d)-(iii)
- (4) (a)-(iii), (b)-(ii), (c)-(i), (d)-(iv)

89. The product formed in the following chemical reaction is :

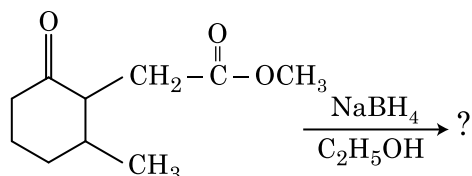

- (1)
- (2)
- (3)
- (4)

90. Choose the correct option for the total pressure (in atm.) in a mixture of 4 g  $O_2$  and 2 g  $H_2$  confined in a total volume of one litre at  $0^\circ C$  is :

[Given  $R = 0.082 \text{ L atm mol}^{-1} \text{ K}^{-1}$ ,  $T = 273 \text{ K}$ ]

- (1) 25.18  
 (2) 26.02  
 (3) 2.518  
 (4) 2.602
91. The correct option for the value of vapour pressure of a solution at  $45^\circ C$  with benzene to octane in molar ratio 3 : 2 is :
- [At  $45^\circ C$  vapour pressure of benzene is 280 mm Hg and that of octane is 420 mm Hg. Assume Ideal gas]
- (1) 336 mm of Hg  
 (2) 350 mm of Hg  
 (3) 160 mm of Hg  
 (4) 168 mm of Hg

92. Which of the following molecules is non-polar in nature ?

- (1)  $SbCl_5$   
 (2)  $NO_2$   
 (3)  $POCl_3$   
 (4)  $CH_2O$

93. The reagent 'R' in the given sequence of chemical reaction is :

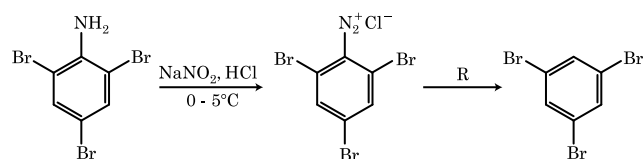

- (1) HI  
 (2)  $CuCN/KCN$   
 (3)  $H_2O$   
 (4)  $CH_3CH_2OH$

94. Match List - I with List - II.

List - I	List - II
(a) $[Fe(CN)_6]^{3-}$	(i) 5.92 BM
(b) $[Fe(H_2O)_6]^{3+}$	(ii) 0 BM
(c) $[Fe(CN)_6]^{4-}$	(iii) 4.90 BM
(d) $[Fe(H_2O)_6]^{2+}$	(iv) 1.73 BM

Choose the **correct** answer from the options given below.

- (1) (a)-(i), (b)-(iii), (c)-(iv), (d)-(ii)  
 (2) (a)-(iv), (b)-(i), (c)-(ii), (d)-(iii)  
 (3) (a)-(iv), (b)-(ii), (c)-(i), (d)-(iii)  
 (4) (a)-(ii), (b)-(iv), (c)-(iii), (d)-(i)
95. From the following pairs of ions which one is not an iso-electronic pair ?
- (1)  $Mn^{2+}$ ,  $Fe^{3+}$   
 (2)  $Fe^{2+}$ ,  $Mn^{2+}$   
 (3)  $O^{2-}$ ,  $F^-$   
 (4)  $Na^+$ ,  $Mg^{2+}$

96. For irreversible expansion of an ideal gas under isothermal condition, the correct option is :

- (1)  $\Delta U = 0$ ,  $\Delta S_{total} \neq 0$   
 (2)  $\Delta U \neq 0$ ,  $\Delta S_{total} = 0$   
 (3)  $\Delta U = 0$ ,  $\Delta S_{total} = 0$   
 (4)  $\Delta U \neq 0$ ,  $\Delta S_{total} \neq 0$

97. The molar conductivity of 0.007 M acetic acid is  $20 \text{ S cm}^2 \text{ mol}^{-1}$ . What is the dissociation constant of acetic acid ? Choose the correct option.

$$\left[ \begin{array}{l} \Lambda_{H^+}^\circ = 350 \text{ S cm}^2 \text{ mol}^{-1} \\ \Lambda_{CH_3COO^-}^\circ = 50 \text{ S cm}^2 \text{ mol}^{-1} \end{array} \right]$$

- (1)  $1.75 \times 10^{-5} \text{ mol L}^{-1}$   
 (2)  $2.50 \times 10^{-5} \text{ mol L}^{-1}$   
 (3)  $1.75 \times 10^{-4} \text{ mol L}^{-1}$   
 (4)  $2.50 \times 10^{-4} \text{ mol L}^{-1}$

98. The slope of Arrhenius Plot  $\left(\ln k \text{ v/s } \frac{1}{T}\right)$  of first order reaction is  $-5 \times 10^3 \text{ K}$ . The value of  $E_a$  of the reaction is. Choose the correct option for your answer.

[Given  $R = 8.314 \text{ JK}^{-1}\text{mol}^{-1}$ ]

- (1)  $166 \text{ kJ mol}^{-1}$   
 (2)  $-83 \text{ kJ mol}^{-1}$   
 (3)  $41.5 \text{ kJ mol}^{-1}$   
 (4)  $83.0 \text{ kJ mol}^{-1}$
99.  $\text{CH}_3\text{CH}_2\text{COO}^- \text{Na}^+ \xrightarrow[\text{Heat}]{\text{NaOH, + ?}} \text{CH}_3\text{CH}_3 + \text{Na}_2\text{CO}_3$ .

Consider the above reaction and identify the missing reagent/chemical.

- (1) CaO  
 (2) DIBAL-H  
 (3)  $\text{B}_2\text{H}_6$   
 (4) Red Phosphorus
100. In which one of the following arrangements the given sequence is not strictly according to the properties indicated against it?
- (1)  $\text{NH}_3 < \text{PH}_3$  : Increasing acidic character  
 $< \text{AsH}_3 < \text{SbH}_3$
- (2)  $\text{CO}_2 < \text{SiO}_2$  : Increasing oxidizing power  
 $< \text{SnO}_2 < \text{PbO}_2$
- (3)  $\text{HF} < \text{HCl}$  : Increasing acidic strength  
 $< \text{HBr} < \text{HI}$
- (4)  $\text{H}_2\text{O} < \text{H}_2\text{S}$  : Increasing  $\text{pK}_a$  values  
 $< \text{H}_2\text{Se} < \text{H}_2\text{Te}$

### Section - A (Biology : Botany)

101. During the purification process for recombinant DNA technology, addition of chilled ethanol precipitates out :
- (1) Histones  
 (2) Polysaccharides  
 (3) RNA  
 (4) DNA
102. A typical angiosperm embryo sac at maturity is :
- (1) 7-nucleate and 7-celled  
 (2) 8-nucleate and 8-celled  
 (3) 8-nucleate and 7-celled  
 (4) 7-nucleate and 8-celled

103. Which of the following is an **incorrect** statement?

- (1) The perinuclear space forms a barrier between the materials present inside the nucleus and that of the cytoplasm.  
 (2) Nuclear pores act as passages for proteins and RNA molecules in both directions between nucleus and cytoplasm.  
 (3) Mature sieve tube elements possess a conspicuous nucleus and usual cytoplasmic organelles.  
 (4) Microbodies are present both in plant and animal cells.

104. The plant hormone used to destroy weeds in a field is :

- (1) 2, 4-D  
 (2) IBA  
 (3) IAA  
 (4) NAA

105. Match List - I with List - II.

List - I		List - II	
(a)	Cells with active cell division capacity	(i)	Vascular tissues
(b)	Tissue having all cells similar in structure and function	(ii)	Meristematic tissue
(c)	Tissue having different types of cells	(iii)	Sclereids
(d)	Dead cells with highly thickened walls and narrow lumen	(iv)	Simple tissue

Select the **correct** answer from the options given below.

- (a) (b) (c) (d)
- (1) (i) (ii) (iii) (iv)  
 (2) (iii) (ii) (iv) (i)  
 (3) (ii) (iv) (i) (iii)  
 (4) (iv) (iii) (ii) (i)

106. Which of the following is **not** an application of PCR (Polymerase Chain Reaction) ?

- (1) Purification of isolated protein  
 (2) Detection of gene mutation  
 (3) Molecular diagnosis  
 (4) Gene amplification

107. Which of the following is a **correct** sequence of steps in a PCR (Polymerase Chain Reaction) ?
- (1) Extension, Denaturation, Annealing
  - (2) Annealing, Denaturation, Extension
  - (3) Denaturation, Annealing, Extension
  - (4) Denaturation, Extension, Annealing
108. When gene targetting involving gene amplification is attempted in an individual's tissue to treat disease, it is known as :
- (1) Molecular diagnosis
  - (2) Safety testing
  - (3) Biopiracy
  - (4) Gene therapy
109. Mutations in plant cells can be induced by :
- (1) Gamma rays
  - (2) Zeatin
  - (3) Kinetin
  - (4) Infrared rays
110. Which of the following algae produce Carrageen ?
- (1) Red algae
  - (2) Blue-green algae
  - (3) Green algae
  - (4) Brown algae
111. Diadelphous stamens are found in :
- (1) Pea
  - (2) China rose and citrus
  - (3) China rose
  - (4) Citrus
112. Which of the following statements is **not** correct ?
- (1) Pyramid of energy is always upright.
  - (2) Pyramid of numbers in a grassland ecosystem is upright.
  - (3) Pyramid of biomass in sea is generally inverted.
  - (4) Pyramid of biomass in sea is generally upright.
113. Which of the following are **not** secondary metabolites in plants ?
- (1) Vinblastin, curcumin
  - (2) Rubber, gums
  - (3) Morphine, codeine
  - (4) Amino acids, glucose
114. Gemmae are present in :
- (1) Some Gymnosperms
  - (2) Some Liverworts
  - (3) Mosses
  - (4) Pteridophytes
115. When the centromere is situated in the middle of two equal arms of chromosomes, the chromosome is referred as :
- (1) Sub-metacentric
  - (2) Acrocentric
  - (3) Metacentric
  - (4) Telocentric
116. The factor that leads to Founder effect in a population is :
- (1) Mutation
  - (2) Genetic drift
  - (3) Natural selection
  - (4) Genetic recombination
117. Genera like *Selaginella* and *Salvinia* produce two kinds of spores. Such plants are known as :
- (1) Homosporous
  - (2) Heterosporous
  - (3) Homosorus
  - (4) Heterosorus
118. In the equation  $GPP - R = NPP$  R represents :
- (1) Environment factor
  - (2) Respiration losses
  - (3) Radiant energy
  - (4) Retardation factor
119. Which of the following plants is monoecious ?
- (1) *Marchantia polymorpha*
  - (2) *Cycas circinalis*
  - (3) *Carica papaya*
  - (4) Chara
120. The amount of nutrients, such as carbon, nitrogen, phosphorus and calcium present in the soil at any given time, is referred as :
- (1) Standing state
  - (2) Standing crop
  - (3) Climax
  - (4) Climax community



121. The term used for transfer of pollen grains from anthers of one plant to stigma of a different plant which, during pollination, brings genetically different types of pollen grains to stigma, is :

- (1) Chasmogamy
- (2) Cleistogamy
- (3) Xenogamy
- (4) Geitonogamy

122. Match List - I with List - II.

List - I		List - II	
(a)	Lenticels	(i)	Phellogen
(b)	Cork cambium	(ii)	Suberin deposition
(c)	Secondary cortex	(iii)	Exchange of gases
(d)	Cork	(iv)	Phelloderm

Choose the **correct** answer from the options given below.

- |     | (a)   | (b)   | (c)   | (d)   |
|-----|-------|-------|-------|-------|
| (1) | (ii)  | (iii) | (iv)  | (i)   |
| (2) | (iv)  | (ii)  | (i)   | (iii) |
| (3) | (iv)  | (i)   | (iii) | (ii)  |
| (4) | (iii) | (i)   | (iv)  | (ii)  |

123. DNA strands on a gel stained with ethidium bromide when viewed under UV radiation, appear as :

- (1) Dark red bands
- (2) Bright blue bands
- (3) Yellow bands
- (4) Bright orange bands

124. Which of the following stages of meiosis involves division of centromere ?

- (1) Anaphase II
- (2) Telophase II
- (3) Metaphase I
- (4) Metaphase II

125. The production of gametes by the parents, formation of zygotes, the  $F_1$  and  $F_2$  plants, can be understood from a diagram called :

- (1) Punnett square
- (2) Net square
- (3) Bullet square
- (4) Punch square

126. Plants follow different pathways in response to environment or phases of life to form different kinds of structures. This ability is called :

- (1) Plasticity
- (2) Maturity
- (3) Elasticity
- (4) Flexibility

127. Amensalism can be represented as :

- (1) Species A (-) ; Species B (-)
- (2) Species A (+) ; Species B (0)
- (3) Species A (-) ; Species B (0)
- (4) Species A (+) ; Species B (+)

128. Match List - I with List - II.

List - I		List - II	
(a)	Protoplast fusion	(i)	Totipotency
(b)	Plant tissue culture	(ii)	Pomato
(c)	Meristem culture	(iii)	Somaclones
(d)	Micropropagation	(iv)	Virus free plants

Choose the **correct** answer from the options given below.

- |     | (a)   | (b)   | (c)  | (d)   |
|-----|-------|-------|------|-------|
| (1) | (iii) | (iv)  | (i)  | (ii)  |
| (2) | (iv)  | (iii) | (ii) | (i)   |
| (3) | (iii) | (iv)  | (ii) | (i)   |
| (4) | (ii)  | (i)   | (iv) | (iii) |

129. In spite of interspecific competition in nature, which mechanism the competing species might have evolved for their survival ?

- (1) Mutualism
- (2) Predation
- (3) Resource partitioning
- (4) Competitive release

130. Which of the following algae contains mannitol as reserve food material ?

- (1) *Volvox*
- (2) *Ulothrix*
- (3) *Ectocarpus*
- (4) *Gracilaria*

131. The site of perception of light in plants during photoperiodism is :

- (1) Axillary bud
- (2) Leaf
- (3) Shoot apex
- (4) Stem

132. The first stable product of CO<sub>2</sub> fixation in sorghum is :

- (1) Succinic acid
- (2) Phosphoglyceric acid
- (3) Pyruvic acid
- (4) Oxaloacetic acid

133. Match List - I with List - II.

List - I		List - II	
(a)	Cristae	(i)	Primary constriction in chromosome
(b)	Thylakoids	(ii)	Disc-shaped sacs in Golgi apparatus
(c)	Centromere	(iii)	Infoldings in mitochondria
(d)	Cisternae	(iv)	Flattened membranous sacs in stroma of plastids

Choose the **correct** answer from the options given below.

- |     |            |            |            |            |
|-----|------------|------------|------------|------------|
|     | <b>(a)</b> | <b>(b)</b> | <b>(c)</b> | <b>(d)</b> |
| (1) | (iii)      | (iv)       | (i)        | (ii)       |
| (2) | (ii)       | (iii)      | (iv)       | (i)        |
| (3) | (iv)       | (iii)      | (ii)       | (i)        |
| (4) | (i)        | (iv)       | (iii)      | (ii)       |

134. Complete the flow chart on central dogma.

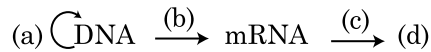

- (1) (a)-Replication; (b)-Transcription; (c)-Translation; (d)-Protein
- (2) (a)-Transduction; (b)-Translation; (c)-Replication; (d)-Protein
- (3) (a)-Replication; (b)-Transcription; (c)-Transduction; (d)-Protein
- (4) (a)-Translation; (b)-Replication; (c)-Transcription; (d)-Transduction

135. Match List - I with List - II.

List - I		List - II	
(a)	Cohesion	(i)	More attraction in liquid phase
(b)	Adhesion	(ii)	Mutual attraction among water molecules
(c)	Surface tension	(iii)	Water loss in liquid phase
(d)	Guttation	(iv)	Attraction towards polar surfaces

Choose the **correct** answer from the options given below.

- |     |            |            |            |            |
|-----|------------|------------|------------|------------|
|     | <b>(a)</b> | <b>(b)</b> | <b>(c)</b> | <b>(d)</b> |
| (1) | (iii)      | (i)        | (iv)       | (ii)       |
| (2) | (ii)       | (i)        | (iv)       | (iii)      |
| (3) | (ii)       | (iv)       | (i)        | (iii)      |
| (4) | (iv)       | (iii)      | (ii)       | (i)        |

**Section - B (Biology : Botany)**

136. Which of the following statements is **incorrect** ?

- (1) Grana lamellae have both PS I and PS II.
- (2) Cyclic photophosphorylation involves both PS I and PS II.
- (3) Both ATP and NADPH + H<sup>+</sup> are synthesized during non-cyclic photophosphorylation.
- (4) Stroma lamellae have PS I only and lack NADP reductase.

137. Select the **correct** pair.

- (1) Cells of medullary rays - Interfascicular cambium that form part of cambial ring
- (2) Loose parenchyma cells - Spongy rupturing the epidermis parenchyma and forming a lens-shaped opening in bark
- (3) Large colorless empty cells in the epidermis of grass leaves - Subsidiary cells
- (4) In dicot leaves, vascular bundles are surrounded by large thick-walled cells - Conjunctive tissue

138. Identify the **correct** statement.

- (1) The coding strand in a transcription unit is copied to an mRNA.
- (2) Split gene arrangement is characteristic of prokaryotes.
- (3) In capping, methyl guanosine triphosphate is added to the 3' end of hnRNA.
- (4) RNA polymerase binds with Rho factor to terminate the process of transcription in bacteria.

139. Match List - I with List - II.

List - I		List - II	
(a)	S phase	(i)	Proteins are synthesized
(b)	G <sub>2</sub> phase	(ii)	Inactive phase
(c)	Quiescent stage	(iii)	Interval between mitosis and initiation of DNA replication
(d)	G <sub>1</sub> phase	(iv)	DNA replication

Choose the **correct** answer from the options given below.

- |     |            |            |            |            |
|-----|------------|------------|------------|------------|
|     | <b>(a)</b> | <b>(b)</b> | <b>(c)</b> | <b>(d)</b> |
| (1) | (iv)       | (i)        | (ii)       | (iii)      |
| (2) | (ii)       | (iv)       | (iii)      | (i)        |
| (3) | (iii)      | (ii)       | (i)        | (iv)       |
| (4) | (iv)       | (ii)       | (iii)      | (i)        |

140. Match Column - I with Column - II.

Column - I		Column - II	
(a)	<i>Nitrococcus</i>	(i)	Denitrification
(b)	<i>Rhizobium</i>	(ii)	Conversion of ammonia to nitrite
(c)	<i>Thiobacillus</i>	(iii)	Conversion of nitrite to nitrate
(d)	<i>Nitrobacter</i>	(iv)	Conversion of atmospheric nitrogen to ammonia

Choose the **correct** answer from options given below.

- |     | (a)   | (b)   | (c)   | (d)   |
|-----|-------|-------|-------|-------|
| (1) | (iii) | (i)   | (iv)  | (ii)  |
| (2) | (iv)  | (iii) | (ii)  | (i)   |
| (3) | (ii)  | (iv)  | (i)   | (iii) |
| (4) | (i)   | (ii)  | (iii) | (iv)  |

141. Match Column - I with Column - II.

Column - I	Column - II
(a) $\% \frac{\phi}{\psi} K_{(5)} C_{1+2+(2)} A_{(9)+1} G_1$	(i) Brassicaceae
(b) $\oplus \frac{\phi}{\psi} K_{(5)} C_{(5)} A_5 G_2$	(ii) Liliaceae
(c) $\oplus \frac{\phi}{\psi} P_{(3+3)} A_{3+3} G_{(3)}$	(iii) Fabaceae
(d) $\oplus \frac{\phi}{\psi} K_{2+2} C_4 A_{2-4} G_{(2)}$	(iv) Solanaceae

Select the **correct** answer from the options given below.

- |     | (a)   | (b)   | (c)   | (d)   |
|-----|-------|-------|-------|-------|
| (1) | (ii)  | (iii) | (iv)  | (i)   |
| (2) | (iv)  | (ii)  | (i)   | (iii) |
| (3) | (iii) | (iv)  | (ii)  | (i)   |
| (4) | (i)   | (ii)  | (iii) | (iv)  |

142. Match List - I with List - II.

List - I		List - II	
(a)	Protein	(i)	C = C double bonds
(b)	Unsaturated fatty acid	(ii)	Phosphodiester bonds
(c)	Nucleic acid	(iii)	Glycosidic bonds
(d)	Polysaccharide	(iv)	Peptide bonds

Choose the **correct** answer from the options given below.

- |     | (a)  | (b)   | (c)   | (d)   |
|-----|------|-------|-------|-------|
| (1) | (ii) | (i)   | (iv)  | (iii) |
| (2) | (iv) | (iii) | (i)   | (ii)  |
| (3) | (iv) | (i)   | (ii)  | (iii) |
| (4) | (i)  | (iv)  | (iii) | (ii)  |

143. Which of the following statements is **incorrect** ?

- (1) ATP is synthesized through complex V.
- (2) Oxidation-reduction reactions produce proton gradient in respiration.
- (3) During aerobic respiration, role of oxygen is limited to the terminal stage.
- (4) In ETC (Electron Transport Chain), one molecule of  $NADH + H^+$  gives rise to 2 ATP molecules, and one  $FADH_2$  gives rise to 3 ATP molecules.

144. DNA fingerprinting involves identifying differences in some specific regions in DNA sequence, called as :

- (1) Single nucleotides
- (2) Polymorphic DNA
- (3) Satellite DNA
- (4) Repetitive DNA

145. Which of the following statements is **correct** ?

- (1) Organisms that depend on living plants are called saprophytes.
- (2) Some of the organisms can fix atmospheric nitrogen in specialized cells called sheath cells.
- (3) Fusion of two cells is called Karyogamy.
- (4) Fusion of protoplasts between two motile on non-motile gametes is called plasmogamy.

146. Now a days it is possible to detect the mutated gene causing cancer by allowing radioactive probe to hybridise its complimentary DNA in a clone of cells, followed by its detection using autoradiography because :

- (1) mutated gene does not appear on a photographic film as the probe has no complementarity with it.
- (2) mutated gene does not appear on photographic film as the probe has complementarity with it.
- (3) mutated gene partially appears on a photographic film.
- (4) mutated gene completely and clearly appears on a photographic film.

147. Plasmid pBR322 has PstI restriction enzyme site within gene  $amp^R$  that confers ampicillin resistance. If this enzyme is used for inserting a gene for  $\beta$ -galactoside production and the recombinant plasmid is inserted in an *E.coli* strain
- (1) it will lead to lysis of host cell.
  - (2) it will be able to produce a novel protein with dual ability.
  - (3) it will not be able to confer ampicillin resistance to the host cell.
  - (4) the transformed cells will have the ability to resist ampicillin as well as produce  $\beta$ -galactoside.
148. In some members of which of the following pairs of families, pollen grains retain their viability for months after release ?
- (1) Poaceae ; Solanaceae
  - (2) Rosaceae ; Leguminosae
  - (3) Poaceae ; Rosaceae
  - (4) Poaceae ; Leguminosae
149. What is the role of RNA polymerase III in the process of transcription in eukaryotes ?
- (1) Transcribes precursor of mRNA
  - (2) Transcribes only snRNAs
  - (3) Transcribes rRNAs (28S, 18S and 5.8S)
  - (4) Transcribes tRNA, 5s rRNA and snRNA
150. In the exponential growth equation  $N_t = N_0 e^{rt}$ ,  $e$  represents :
- (1) The base of natural logarithms
  - (2) The base of geometric logarithms
  - (3) The base of number logarithms
  - (4) The base of exponential logarithms

### Section - A (Biology : Zoology)

151. Read the following statements.
- (a) Metagenesis is observed in Helminths.
  - (b) Echinoderms are triploblastic and coelomate animals.
  - (c) Round worms have organ-system level of body organization.
  - (d) Comb plates present in ctenophores help in digestion.
  - (e) Water vascular system is characteristic of Echinoderms.
- Choose the **correct** answer from the options given below.
- (1) (a), (d) and (e) are correct
  - (2) (b), (c) and (e) are correct
  - (3) (c), (d) and (e) are correct
  - (4) (a), (b) and (c) are correct

152. Match List - I with List - II.

List - I		List - II	
(a)	Metamerism	(i)	Coelenterata
(b)	Canal system	(ii)	Ctenophora
(c)	Comb plates	(iii)	Annelida
(d)	Cnidoblasts	(iv)	Porifera

Choose the **correct** answer from the options given below.

- |     | (a)   | (b)   | (c)  | (d)   |
|-----|-------|-------|------|-------|
| (1) | (iii) | (iv)  | (ii) | (i)   |
| (2) | (iv)  | (i)   | (ii) | (iii) |
| (3) | (iv)  | (iii) | (i)  | (ii)  |
| (4) | (iii) | (iv)  | (i)  | (ii)  |

153. Which of the following statements wrongly represents the nature of smooth muscle ?

- (1) Communication among the cells is performed by intercalated discs
- (2) These muscles are present in the wall of blood vessels
- (3) These muscle have no striations
- (4) They are involuntary muscles

154. The centriole undergoes duplication during :

- (1) Metaphase
- (2)  $G_2$  phase
- (3) S-phase
- (4) Prophase

155. With regard to insulin choose correct options.

- (a) C-peptide is not present in mature insulin.
- (b) The insulin produced by rDNA technology has C-peptide.
- (c) The pro-insulin has C-peptide.
- (d) A-peptide and B-peptide of insulin are interconnected by disulphide bridges.

Choose the **correct** answer from the options given below.

- (1) (a), (c) and (d) only
- (2) (a) and (d) only
- (3) (b) and (d) only
- (4) (b) and (c) only

156. Match List - I with List - II.

List - I		List - II	
(a)	Vaults	(i)	Entry of sperm through Cervix is blocked
(b)	IUDs	(ii)	Removal of Vas deferens
(c)	Vasectomy	(iii)	Phagocytosis of sperms within the Uterus
(d)	Tubectomy	(iv)	Removal of fallopian tube

Choose the **correct** answer from the options given below.

- (a) (b) (c) (d)
- (1) (ii) (iv) (iii) (i)
- (2) (iii) (i) (iv) (ii)
- (3) (iv) (ii) (i) (iii)
- (4) (i) (iii) (ii) (iv)
157. Which of the following RNAs is not required for the synthesis of protein ?
- (1) rRNA
- (2) siRNA
- (3) mRNA
- (4) tRNA
158. Identify the **incorrect** pair.
- (1) Lectins - Concanavalin A
- (2) Drugs - Ricin
- (3) Alkaloids - Codeine
- (4) Toxin - Abrin
159. A specific recognition sequence identified by endonucleases to make cuts at specific positions within the DNA is :
- (1) Palindromic Nucleotide sequences
- (2) Poly(A) tail sequences
- (3) Degenerate primer sequence
- (4) Okazaki sequences
160. Which of the following is **not** an objective of Biofortification in crops ?
- (1) Improve vitamin content
- (2) Improve micronutrient and mineral content
- (3) Improve protein content
- (4) Improve resistance to diseases
161. Chronic auto immune disorder affecting neuro muscular junction leading to fatigue, weakening and paralysis of skeletal muscle is called as :
- (1) Myasthenia gravis
- (2) Gout
- (3) Arthritis
- (4) Muscular dystrophy

162. Which one of the following belongs to the family Muscidae ?
- (1) Cockroach
- (2) House fly
- (3) Fire fly
- (4) Grasshopper
163. The partial pressures (in mm Hg) of oxygen ( $O_2$ ) and carbon dioxide ( $CO_2$ ) at alveoli (the site of diffusion) are :
- (1)  $pO_2 = 95$  and  $pCO_2 = 40$
- (2)  $pO_2 = 159$  and  $pCO_2 = 0.3$
- (3)  $pO_2 = 104$  and  $pCO_2 = 40$
- (4)  $pO_2 = 40$  and  $pCO_2 = 45$
164. During the process of gene amplification using PCR, if very high temperature is not maintained in the beginning, then which of the following steps of PCR will be affected first ?
- (1) Denaturation
- (2) Ligation
- (3) Annealing
- (4) Extension
165. Which enzyme is responsible for the conversion of inactive fibrinogens to fibrins ?
- (1) Epinephrine
- (2) Thrombokinase
- (3) Thrombin
- (4) Renin
166. The organelles that are included in the endomembrane system are :
- (1) Golgi complex, Mitochondria, Ribosomes and Lysosomes
- (2) Golgi complex, Endoplasmic reticulum, Mitochondria and Lysosomes
- (3) Endoplasmic reticulum, Mitochondria, Ribosomes and Lysosomes
- (4) Endoplasmic reticulum, Golgi complex, Lysosomes and Vacuoles
167. Which one of the following is an example of Hormone releasing IUD ?
- (1) Cu 7
- (2) Multiload 375
- (3) CuT
- (4) LNG 20

168. Succus entericus is referred to as :
- (1) Gastric juice
  - (2) Chyme
  - (3) Pancreatic juice
  - (4) Intestinal juice
169. Select the favourable conditions required for the formation of oxyhaemoglobin at the alveoli.
- (1) High  $pO_2$ , high  $pCO_2$ , less  $H^+$ , higher temperature
  - (2) Low  $pO_2$ , low  $pCO_2$ , more  $H^+$ , higher temperature
  - (3) High  $pO_2$ , low  $pCO_2$ , less  $H^+$ , lower temperature
  - (4) Low  $pO_2$ , high  $pCO_2$ , more  $H^+$ , higher temperature
170. Veneral diseases can spread through :
- (a) Using sterile needles
  - (b) Transfusion of blood from infected person
  - (c) Infected mother to foetus
  - (d) Kissing
  - (e) Inheritance
- Choose the **correct** answer from the options given below.
- (1) (b) and (c) only
  - (2) (a) and (c) only
  - (3) (a), (b) and (c) only
  - (4) (b), (c) and (d) only
171. The fruit fly has 8 chromosomes ( $2n$ ) in each cell. During interphase of Mitosis if the number of chromosomes at  $G_1$  phase is 8, what would be the number of chromosomes after S phase ?
- (1) 4
  - (2) 32
  - (3) 8
  - (4) 16
172. If Adenine makes 30% of the DNA molecule, what will be the percentage of Thymine, Guanine and Cytosine in it ?
- (1) T : 30 ; G : 20 ; C : 20
  - (2) T : 20 ; G : 25 ; C : 25
  - (3) T : 20 ; G : 30 ; C : 20
  - (4) T : 20 ; G : 20 ; C : 30

173. Which one of the following organisms bears hollow and pneumatic long bones ?
- (1) *Macropus*
  - (2) *Ornithorhynchus*
  - (3) *Neophron*
  - (4) *Hemidactylus*
174. Which is the "Only enzyme" that has "Capability" to catalyse Initiation, Elongation and Termination in the process of transcription in prokaryotes ?
- (1) DNA Ligase
  - (2) DNase
  - (3) DNA dependent DNA polymerase
  - (4) DNA dependent RNA polymerase
175. Match the following :

List - I		List - II	
(a)	<i>Physalia</i>	(i)	Pearl oyster
(b)	<i>Limulus</i>	(ii)	Portuguese Man of War
(c)	<i>Ancylostoma</i>	(iii)	Living fossil
(d)	<i>Pinctada</i>	(iv)	Hookworm

Choose the **correct** answer from the options given below.

- |  |            |            |            |            |
|--|------------|------------|------------|------------|
|  | <b>(a)</b> | <b>(b)</b> | <b>(c)</b> | <b>(d)</b> |
|--|------------|------------|------------|------------|
- (1) (ii) (iii) (iv) (i)
  - (2) (i) (iv) (iii) (ii)
  - (3) (ii) (iii) (i) (iv)
  - (4) (iv) (i) (iii) (ii)
176. Which stage of meiotic prophase shows terminalisation of chiasmata as its distinctive feature ?
- (1) Diakinesis
  - (2) Pachytene
  - (3) Leptotene
  - (4) Zygotene
177. Dobson units are used to measure thickness of :
- (1) Ozone
  - (2) Troposphere
  - (3) CFCs
  - (4) Stratosphere
178. Sphincter of oddi is present at :
- (1) Gastro-oesophageal junction
  - (2) Junction of jejunum and duodenum
  - (3) Ileo-caecal junction
  - (4) Junction of hepato-pancreatic duct and duodenum

179. In a cross between a male and female, both heterozygous for sickle cell anaemia gene, what percentage of the progeny will be diseased ?

- (1) 25%
- (2) 100%
- (3) 50%
- (4) 75%

180. Persons with 'AB' blood group are called as "Universal recipients". This is due to :

- (1) Presence of antibodies, anti-A and anti-B, on RBCs
- (2) Absence of antibodies, anti-A and anti-B, in plasma
- (3) Absence of antigens A and B on the surface of RBCs
- (4) Absence of antigens A and B in plasma

181. Which of the following characteristics is **incorrect** with respect to cockroach ?

- (1) In females, 7<sup>th</sup>-9<sup>th</sup> sterna together form a genital pouch.
- (2) 10<sup>th</sup> abdominal segment in both sexes, bears a pair of anal cerci.
- (3) A ring of gastric caeca is present at the junction of midgut and hind gut.
- (4) Hypopharynx lies within the cavity enclosed by the mouth parts.

182. Erythropoietin hormone which stimulates R.B.C. formation is produced by :

- (1) The cells of bone marrow
- (2) Juxtaglomerular cells of the kidney
- (3) Alpha cells of pancreas
- (4) The cells of rostral adenohypophysis

183. Match List - I with List - II.

List - I		List - II	
(a)	<i>Aspergillus niger</i>	(i)	Acetic Acid
(b)	<i>Acetobacter aceti</i>	(ii)	Lactic Acid
(c)	<i>Clostridium butylicum</i>	(iii)	Citric Acid
(d)	<i>Lactobacillus</i>	(iv)	Butyric Acid

Choose the **correct** answer from the options given below.

- |     | (a)   | (b)   | (c)   | (d)   |
|-----|-------|-------|-------|-------|
| (1) | (ii)  | (iii) | (i)   | (iv)  |
| (2) | (iv)  | (ii)  | (i)   | (iii) |
| (3) | (iii) | (i)   | (iv)  | (ii)  |
| (4) | (i)   | (ii)  | (iii) | (iv)  |

184. Receptors for sperm binding in mammals are present on :

- (1) Perivitelline space
- (2) Zona pellucida
- (3) Corona radiata
- (4) Vitelline membrane

185. For effective treatment of the disease, early diagnosis and understanding its pathophysiology is very important. Which of the following molecular diagnostic techniques is very useful for early detection ?

- (1) ELISA Technique
- (2) Hybridization Technique
- (3) Western Blotting Technique
- (4) Southern Blotting Technique

### Section - B (Biology : Zoology)

186. **Statement I :**

The codon 'AUG' codes for methionine and phenylalanine.

**Statement II :**

'AAA' and 'AAG' both codons code for the amino acid lysine.

In the light of the above statements, choose the **correct** answer from the options given below.

- (1) **Statement I** is correct but **Statement II** is false
- (2) **Statement I** is incorrect but **Statement II** is true
- (3) Both **Statement I** and **Statement II** are true
- (4) Both **Statement I** and **Statement II** are false

187. Match List - I with List - II.

List - I		List - II	
(a)	Scapula	(i)	Cartilaginous joints
(b)	Cranium	(ii)	Flat bone
(c)	Sternum	(iii)	Fibrous joints
(d)	Vertebral column	(iv)	Triangular flat bone

Choose the **correct** answer from the options given below.

- |     | (a)  | (b)   | (c)   | (d)  |
|-----|------|-------|-------|------|
| (1) | (iv) | (ii)  | (iii) | (i)  |
| (2) | (iv) | (iii) | (ii)  | (i)  |
| (3) | (i)  | (iii) | (ii)  | (iv) |
| (4) | (ii) | (iii) | (iv)  | (i)  |

188. Which of the following is **not** a step in Multiple Ovulation Embryo Transfer Technology (MOET) ?

- (1) Cow is fertilized by artificial insemination
- (2) Fertilized eggs are transferred to surrogate mothers at 8-32 cell stage
- (3) Cow is administered hormone having LH like activity for super ovulation
- (4) Cow yields about 6-8 eggs at a time

189. Which of the following secretes the hormone, relaxin, during the later phase of pregnancy ?

- (1) Foetus
- (2) Uterus
- (3) Graafian follicle
- (4) Corpus luteum

190. Which one of the following statements about Histones is **wrong** ?

- (1) Histones are rich in amino acids - Lysine and Arginine.
- (2) Histones carry positive charge in the side chain.
- (3) Histones are organized to form a unit of 8 molecules.
- (4) The pH of histones is slightly acidic.

191. Identify the types of cell junctions that help to stop the leakage of the substances across a tissue and facilitation of communication with neighbouring cells via rapid transfer of ions and molecules.

- (1) Adhering junctions and Tight junctions, respectively.
- (2) Adhering junctions and Gap junctions, respectively.
- (3) Gap junctions and Adhering junctions, respectively.
- (4) Tight junctions and Gap junctions, respectively.

192. Following are the statements with reference to 'lipids'.

- (a) Lipids having only single bonds are called unsaturated fatty acids.
- (b) Lecithin is a phospholipid.
- (c) Trihydroxy propane is glycerol.
- (d) Palmitic acid has 20 carbon atoms including carboxyl carbon.
- (e) Arachidonic acid has 16 carbon atoms.

Choose the **correct** answer from the options given below.

- (1) (b) and (c) only
- (2) (b) and (e) only
- (3) (a) and (b) only
- (4) (c) and (d) only

193. Match List - I with List - II.

List - I		List - II	
(a)	Filariasis	(i)	<i>Haemophilus influenzae</i>
(b)	Amoebiasis	(ii)	<i>Trichophyton</i>
(c)	Pneumonia	(iii)	<i>Wuchereria bancrofti</i>
(d)	Ringworm	(iv)	<i>Entamoeba histolytica</i>

Choose the **correct** answer from the options given below.

- |     |            |            |            |            |
|-----|------------|------------|------------|------------|
|     | <b>(a)</b> | <b>(b)</b> | <b>(c)</b> | <b>(d)</b> |
| (1) | (i)        | (ii)       | (iv)       | (iii)      |
| (2) | (ii)       | (iii)      | (i)        | (iv)       |
| (3) | (iv)       | (i)        | (iii)      | (ii)       |
| (4) | (iii)      | (iv)       | (i)        | (ii)       |

194. During muscular contraction which of the following events occur ?

- (a) 'H' zone disappears
- (b) 'A' band widens
- (c) 'T' band reduces in width
- (d) Myosine hydrolyzes ATP, releasing the ADP and Pi
- (e) Z-lines attached to actins are pulled inwards

Choose the **correct** answer from the options given below.

- (1) (b), (c), (d), (e) only
- (2) (b), (d), (e), (a) only
- (3) (a), (c), (d), (e) only
- (4) (a), (b), (c), (d) only



## 195. Assertion (A) :

A person goes to high altitude and experiences 'altitude sickness' with symptoms like breathing difficulty and heart palpitations.

## Reason (R) :

Due to low atmospheric pressure at high altitude, the body does not get sufficient oxygen.

In the light of the above statements, choose the correct answer from the options given below.

- (1) (A) is true but (R) is false
- (2) (A) is false but (R) is true
- (3) Both (A) and (R) are true and (R) is the correct explanation of (A)
- (4) Both (A) and (R) are true but (R) is not the correct explanation of (A)

## 196. Match List - I with List - II.

List - I		List - II	
(a)	Adaptive radiation	(i)	Selection of resistant varieties due to excessive use of herbicides and pesticides
(b)	Convergent evolution	(ii)	Bones of forelimbs in Man and Whale
(c)	Divergent evolution	(iii)	Wings of Butterfly and Bird
(d)	Evolution by anthropogenic action	(iv)	Darwin Finches

Choose the correct answer from the options given below.

- |     | (a)   | (b)   | (c)   | (d)   |
|-----|-------|-------|-------|-------|
| (1) | (ii)  | (i)   | (iv)  | (iii) |
| (2) | (i)   | (iv)  | (iii) | (ii)  |
| (3) | (iv)  | (iii) | (ii)  | (i)   |
| (4) | (iii) | (ii)  | (i)   | (iv)  |

## 197. Following are the statements about prostomium of earthworm.

- (a) It serves as a covering for mouth.
- (b) It helps to open cracks in the soil into which it can crawl.
- (c) It is one of the sensory structures.
- (d) It is the first body segment.

Choose the correct answer from the options given below.

- (1) (a), (b), (c) and (d) are correct
- (2) (b) and (c) are correct
- (3) (a), (b) and (c) are correct
- (4) (a), (b) and (d) are correct

## 198. The Adenosine deaminase deficiency results into :

- (1) Digestive disorder
- (2) Addison's disease
- (3) Dysfunction of Immune system
- (4) Parkinson's disease

## 199. Match List - I with List - II.

List - I		List - II	
(a)	Allen's Rule	(i)	Kangaroo rat
(b)	Physiological adaptation	(ii)	Desert lizard
(c)	Behavioural adaptation	(iii)	Marine fish at depth
(d)	Biochemical adaptation	(iv)	Polar seal

Choose the correct answer from the options given below.

- |     | (a)  | (b)   | (c)   | (d)   |
|-----|------|-------|-------|-------|
| (1) | (iv) | (i)   | (ii)  | (iii) |
| (2) | (iv) | (iii) | (ii)  | (i)   |
| (3) | (iv) | (ii)  | (iii) | (i)   |
| (4) | (iv) | (i)   | (iii) | (ii)  |

## 200. Which of these is not an important component of initiation of parturition in humans ?

- (1) Release of Oxytocin
- (2) Release of Prolactin
- (3) Increase in estrogen and progesterone ratio
- (4) Synthesis of prostaglandins

**01**

**26**

**Space For Rough Work**

**Space For Rough Work**

01

28

**Space For Rough Work**

Test Booklet Code

**P1**

**GAJAH**

No. :

This Booklet contains 28 pages.

**Do not open this Test Booklet until you are asked to do so.**

**Important Instructions :**

1. The Answer Sheet is inside this Test Booklet. When you are directed to open the Test Booklet, take out the Answer Sheet and fill in the particulars on OFFICE Copy carefully with **blue/black** ball point pen only.
2. The test is of **3 hours** duration and the Test Booklet contains **200** multiple-choice questions (four options with a single correct answer) from **Physics, Chemistry and Biology (Botany and Zoology)**. **50** questions in each subject are divided into **two Sections (A and B)** as per details given below :
  - (a) **Section A** shall consist of **35 (Thirty-five)** Questions in each subject (Question Nos – 1 to 35, 51 to 85, 101 to 135 and 151 to 185). All questions are compulsory.
  - (b) **Section B** shall consist of **15 (Fifteen)** questions in each subject (Question Nos – 36 to 50, 86 to 100, 136 to 150 and 186 to 200). In Section B, a candidate needs to **attempt any 10 (Ten)** questions out of **15 (Fifteen)** in each subject.

**Candidates are advised to read all 15 questions in each subject of Section B before they start attempting the question paper. In the event of a candidate attempting more than ten questions, the first ten questions answered by the candidate shall be evaluated.**
3. Each question carries **4** marks. For each correct response, the candidate will get **4** marks. For each incorrect response, **one** mark will be deducted from the total scores. **The maximum marks are 720.**
4. Use **Blue/Black Ball Point Pen only** for writing particulars on this page/markings responses on Answer Sheet.
5. Rough work is to be done in the space provided for this purpose in the Test Booklet only.
6. On completion of the test, the candidate **must hand over the Answer Sheet (ORIGINAL and OFFICE Copy) to the Invigilator** before leaving the Room/Hall. The candidates are allowed to take away this Test Booklet with them.
7. **The CODE for this Booklet is P1. Make sure that the CODE printed on the Original Copy of the Answer Sheet is the same as that on this Test Booklet.** In case of discrepancy, the candidate should immediately report the matter to the Invigilator for replacement of both the Test Booklet and the Answer Sheet.
8. The candidates should ensure that the Answer Sheet is not folded. Do not make any stray marks on the Answer Sheet. Do not write your Roll No. anywhere else except in the specified space in the Test Booklet/ Answer Sheet.
9. Use of white fluid for correction is **NOT** permissible on the Answer Sheet.
10. Each candidate must show on-demand his/her Admit Card to the Invigilator.
11. No candidate, without special permission of the centre Superintendent or Invigilator, would leave his/her seat.
12. The candidates should not leave the Examination Hall without handing over their Answer Sheet to the Invigilator on duty and sign (with time) the Attendance Sheet **twice**. **Cases, where a candidate has not signed the Attendance Sheet second time, will be deemed not to have handed over the Answer Sheet and dealt with as an Unfair Means case.**
13. Use of Electronic/Manual Calculator is prohibited.
14. The candidates are governed by all Rules and Regulations of the examination with regard to their conduct in the Examination Room/Hall. All cases of unfair means will be dealt with as per the Rules and Regulations of this examination.
15. **No part of the Test Booklet and Answer Sheet shall be detached under any circumstances.**
16. The candidates will write the Correct Test Booklet Code as given in the Test Booklet/Answer Sheet in the Attendance Sheet.

Name of the Candidate (in Capitals) : \_\_\_\_\_

Roll Number : in figures \_\_\_\_\_

: in words \_\_\_\_\_

Centre of Examination (in Capitals) : \_\_\_\_\_

Candidate's Signature : \_\_\_\_\_ Invigilator's Signature : \_\_\_\_\_

Facsimile signature stamp of  
Centre Superintendent : \_\_\_\_\_

**Section - A (Physics)**

1. In a potentiometer circuit a cell of EMF 1.5 V gives balance point at 36 cm length of wire. If another cell of EMF 2.5 V replaces the first cell, then at what length of the wire, the balance point occurs ?

- (1) 62 cm
- (2) 60 cm
- (3) 21.6 cm
- (4) 64 cm

2. **Column - I** gives certain physical terms associated with flow of current through a metallic conductor. **Column - II** gives some mathematical relations involving electrical quantities. Match **Column - I** and **Column - II** with appropriate relations.

Column - I	Column - II
(A) Drift Velocity	(P) $\frac{m}{ne^2\rho}$
(B) Electrical Resistivity	(Q) $nev_d$
(C) Relaxation Period	(R) $\frac{eE}{m}\tau$
(D) Current Density	(S) $\frac{E}{J}$

- (1) (A)-(R), (B)-(Q), (C)-(S), (D)-(P)
- (2) (A)-(R), (B)-(S), (C)-(P), (D)-(Q)
- (3) (A)-(R), (B)-(S), (C)-(Q), (D)-(P)
- (4) (A)-(R), (B)-(P), (C)-(S), (D)-(Q)

3. An infinitely long straight conductor carries a current of 5 A as shown. An electron is moving with a speed of  $10^5$  m/s parallel to the conductor. The perpendicular distance between the electron and the conductor is 20 cm at an instant. Calculate the magnitude of the force experienced by the electron at that instant.

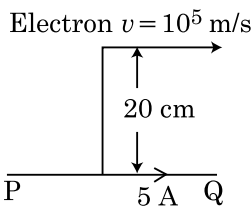

- (1)  $8 \times 10^{-20}$  N
- (2)  $4 \times 10^{-20}$  N
- (3)  $8\pi \times 10^{-20}$  N
- (4)  $4\pi \times 10^{-20}$  N

4. Polar molecules are the molecules :  
 (1) having a permanent electric dipole moment.  
 (2) having zero dipole moment.  
 (3) acquire a dipole moment only in the presence of electric field due to displacement of charges.  
 (4) acquire a dipole moment only when magnetic field is absent.

5. A cup of coffee cools from  $90^\circ\text{C}$  to  $80^\circ\text{C}$  in  $t$  minutes, when the room temperature is  $20^\circ\text{C}$ . The time taken by a similar cup of coffee to cool from  $80^\circ\text{C}$  to  $60^\circ\text{C}$  at a room temperature same at  $20^\circ\text{C}$  is :

- (1)  $\frac{5}{13}t$
- (2)  $\frac{13}{10}t$
- (3)  $\frac{13}{5}t$
- (4)  $\frac{10}{13}t$

6. Consider the following **statements (A)** and **(B)** and identify the **correct** answer.

- (A) A zener diode is connected in reverse bias, when used as a voltage regulator.
  - (B) The potential barrier of p-n junction lies between 0.1 V to 0.3 V.
- (1) (A) is incorrect but (B) is correct.
  - (2) (A) and (B) both are correct.
  - (3) (A) and (B) both are incorrect.
  - (4) (A) is correct and (B) is incorrect.

7. A nucleus with mass number 240 breaks into two fragments each of mass number 120, the binding energy per nucleon of unfragmented nuclei is 7.6 MeV while that of fragments is 8.5 MeV. The total gain in the Binding Energy in the process is :

- (1) 216 MeV
- (2) 0.9 MeV
- (3) 9.4 MeV
- (4) 804 MeV

8. Two charged spherical conductors of radius  $R_1$  and  $R_2$  are connected by a wire. Then the ratio of surface charge densities of the spheres ( $\sigma_1/\sigma_2$ ) is :

- (1)  $\frac{R_1^2}{R_2^2}$
- (2)  $\frac{R_1}{R_2}$
- (3)  $\frac{R_2}{R_1}$
- (4)  $\sqrt{\left(\frac{R_1}{R_2}\right)}$

9. A body is executing simple harmonic motion with frequency 'n', the frequency of its potential energy is :

- (1)  $4n$
- (2)  $n$
- (3)  $2n$
- (4)  $3n$

10. The half-life of a radioactive nuclide is 100 hours. The fraction of original activity that will remain after 150 hours would be :

- (1)  $\frac{2}{3\sqrt{2}}$
- (2)  $1/2$
- (3)  $\frac{1}{2\sqrt{2}}$
- (4)  $\frac{2}{3}$

11. For a plane electromagnetic wave propagating in  $x$ -direction, which one of the following combination gives the correct possible directions for electric field ( $\vec{E}$ ) and magnetic field ( $\vec{B}$ ) respectively ?

- (1)  $-\hat{j} + \hat{k}, -\hat{j} + \hat{k}$
- (2)  $\hat{j} + \hat{k}, \hat{j} + \hat{k}$
- (3)  $-\hat{j} + \hat{k}, -\hat{j} - \hat{k}$
- (4)  $\hat{j} + \hat{k}, -\hat{j} - \hat{k}$

12. A parallel plate capacitor has a uniform electric field ' $\vec{E}$ ' in the space between the plates. If the distance between the plates is 'd' and the area of each plate is 'A', the energy stored in the capacitor is : ( $\epsilon_0$  = permittivity of free space)

- (1)  $\frac{E^2 Ad}{\epsilon_0}$
- (2)  $\frac{1}{2} \epsilon_0 E^2$
- (3)  $\epsilon_0 EAd$
- (4)  $\frac{1}{2} \epsilon_0 E^2 Ad$

13. If force [F], acceleration [A] and time [T] are chosen as the fundamental physical quantities. Find the dimensions of energy.

- (1)  $[F] [A^{-1}] [T]$
- (2)  $[F] [A] [T]$
- (3)  $[F] [A] [T^2]$
- (4)  $[F] [A] [T^{-1}]$

14. A particle is released from height S from the surface of the Earth. At a certain height its kinetic energy is three times its potential energy. The height from the surface of earth and the speed of the particle at that instant are respectively :

- (1)  $\frac{S}{4}, \sqrt{\frac{3gS}{2}}$
- (2)  $\frac{S}{4}, \frac{3gS}{2}$
- (3)  $\frac{S}{4}, \frac{\sqrt{3gS}}{2}$
- (4)  $\frac{S}{2}, \frac{\sqrt{3gS}}{2}$

15. The equivalent capacitance of the combination shown in the figure is :

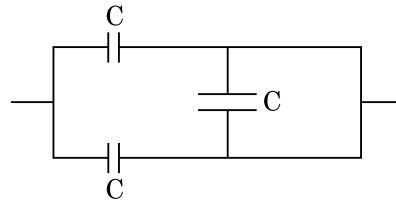

- (1)  $3C/2$
- (2)  $3C$
- (3)  $2C$
- (4)  $C/2$

16. If E and G respectively denote energy and gravitational constant, then  $\frac{E}{G}$  has the dimensions of :

- (1)  $[M^2] [L^{-2}] [T^{-1}]$
- (2)  $[M^2] [L^{-1}] [T^0]$
- (3)  $[M] [L^{-1}] [T^{-1}]$
- (4)  $[M] [L^0] [T^0]$

17. A lens of large focal length and large aperture is best suited as an objective of an astronomical telescope since :

- (1) a large aperture contributes to the quality and visibility of the images.
- (2) a large area of the objective ensures better light gathering power.
- (3) a large aperture provides a better resolution.
- (4) all of the above.

P1

4

18. Find the value of the angle of emergence from the prism. Refractive index of the glass is  $\sqrt{3}$ .

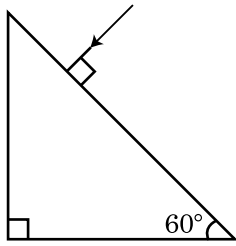

- (1)  $90^\circ$   
 (2)  $60^\circ$   
 (3)  $30^\circ$   
 (4)  $45^\circ$
19. A dipole is placed in an electric field as shown. In which direction will it move ?

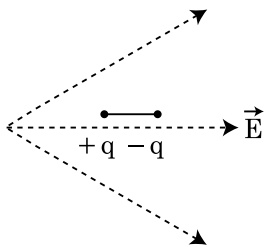

- (1) towards the right as its potential energy will increase.  
 (2) towards the left as its potential energy will increase.  
 (3) towards the right as its potential energy will decrease.  
 (4) towards the left as its potential energy will decrease.
20. A screw gauge gives the following readings when used to measure the diameter of a wire

Main scale reading : 0 mm

Circular scale reading : 52 divisions

Given that 1 mm on main scale corresponds to 100 divisions on the circular scale. The diameter of the wire from the above data is :

- (1) 0.052 cm  
 (2) 0.52 cm  
 (3) 0.026 cm  
 (4) 0.26 cm

21. A small block slides down on a smooth inclined plane, starting from rest at time  $t=0$ . Let  $S_n$  be the distance travelled by the block in the interval  $t = n - 1$  to  $t = n$ . Then, the ratio  $\frac{S_n}{S_{n+1}}$  is :

- (1)  $\frac{2n}{2n-1}$   
 (2)  $\frac{2n-1}{2n}$   
 (3)  $\frac{2n-1}{2n+1}$   
 (4)  $\frac{2n+1}{2n-1}$

22. A convex lens 'A' of focal length 20 cm and a concave lens 'B' of focal length 5 cm are kept along the same axis with a distance 'd' between them. If a parallel beam of light falling on 'A' leaves 'B' as a parallel beam, then the distance 'd' in cm will be :

- (1) 30  
 (2) 25  
 (3) 15  
 (4) 50

23. The escape velocity from the Earth's surface is  $v$ . The escape velocity from the surface of another planet having a radius, four times that of Earth and same mass density is :

- (1)  $4v$   
 (2)  $v$   
 (3)  $2v$   
 (4)  $3v$

24. An inductor of inductance L, a capacitor of capacitance C and a resistor of resistance 'R' are connected in series to an ac source of potential difference 'V' volts as shown in figure.

Potential difference across L, C and R is 40 V, 10 V and 40 V, respectively. The amplitude of current flowing through LCR series circuit is  $10\sqrt{2}$  A. The impedance of the circuit is :

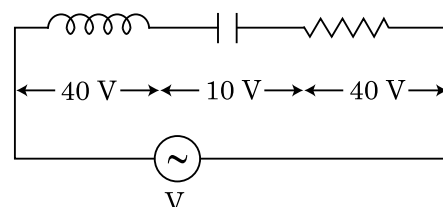

- (1)  $5 \Omega$   
 (2)  $4\sqrt{2} \Omega$   
 (3)  $5/\sqrt{2} \Omega$   
 (4)  $4 \Omega$



25. A spring is stretched by 5 cm by a force 10 N. The time period of the oscillations when a mass of 2 kg is suspended by it is :
- (1) 0.628 s
  - (2) 0.0628 s
  - (3) 6.28 s
  - (4) 3.14 s

26. A thick current carrying cable of radius 'R' carries current 'I' uniformly distributed across its cross-section. The variation of magnetic field B(r) due to the cable with the distance 'r' from the axis of the cable is represented by :

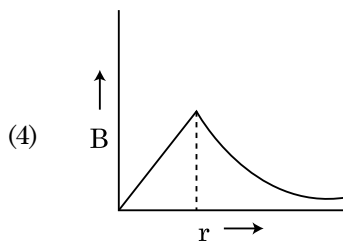
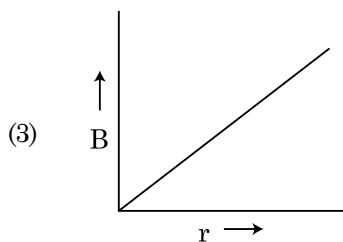
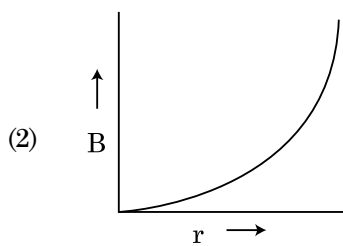
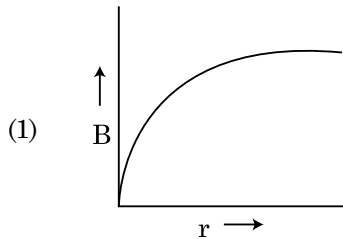

27. A radioactive nucleus  ${}^A_ZX$  undergoes spontaneous decay in the sequence  ${}^A_ZX \rightarrow {}^{Z-1}B \rightarrow {}^{Z-3}C \rightarrow {}^{Z-2}D$ , where Z is the atomic number of element X. The possible decay particles in the sequence are :
- (1)  $\beta^-$ ,  $\alpha$ ,  $\beta^+$
  - (2)  $\alpha$ ,  $\beta^-$ ,  $\beta^+$
  - (3)  $\alpha$ ,  $\beta^+$ ,  $\beta^-$
  - (4)  $\beta^+$ ,  $\alpha$ ,  $\beta^-$

28. The velocity of a small ball of mass M and density d, when dropped in a container filled with glycerine becomes constant after some time. If the density of glycerine is  $\frac{d}{2}$ , then the viscous force acting on the ball will be :

- (1) 2Mg
- (2)  $\frac{Mg}{2}$
- (3) Mg
- (4)  $\frac{3}{2}Mg$

29. Water falls from a height of 60 m at the rate of 15 kg/s to operate a turbine. The losses due to frictional force are 10% of the input energy. How much power is generated by the turbine ? ( $g = 10 \text{ m/s}^2$ )

- (1) 7.0 kW
- (2) 10.2 kW
- (3) 8.1 kW
- (4) 12.3 kW

30. A capacitor of capacitance 'C', is connected across an ac source of voltage V, given by

$$V = V_0 \sin \omega t$$

The displacement current between the plates of the capacitor, would then be given by :

- (1)  $I_d = V_0 \omega C \sin \omega t$
- (2)  $I_d = V_0 \omega C \cos \omega t$
- (3)  $I_d = \frac{V_0}{\omega C} \cos \omega t$
- (4)  $I_d = \frac{V_0}{\omega C} \sin \omega t$

31. The number of photons per second on an average emitted by the source of monochromatic light of wavelength 600 nm, when it delivers the power of  $3.3 \times 10^{-3}$  watt will be : ( $h = 6.6 \times 10^{-34} \text{ Js}$ )

- (1)  $10^{15}$
- (2)  $10^{18}$
- (3)  $10^{17}$
- (4)  $10^{16}$

32. The electron concentration in an n-type semiconductor is the same as hole concentration in a p-type semiconductor. An external field (electric) is applied across each of them. Compare the currents in them.

- (1) No current will flow in p-type, current will only flow in n-type.
- (2) current in n-type = current in p-type.
- (3) current in p-type > current in n-type.
- (4) current in n-type > current in p-type.

33. The effective resistance of a parallel connection that consists of four wires of equal length, equal area of cross-section and same material is  $0.25 \Omega$ . What will be the effective resistance if they are connected in series?

- (1)  $4 \Omega$
- (2)  $0.25 \Omega$
- (3)  $0.5 \Omega$
- (4)  $1 \Omega$

34. Match **Column - I** and **Column - II** and choose the **correct** match from the given choices.

Column - I	Column - II
(A) Root mean square speed of gas molecules	(P) $\frac{1}{3}nm\bar{v}^2$
(B) Pressure exerted by ideal gas	(Q) $\sqrt{\frac{3RT}{M}}$
(C) Average kinetic energy of a molecule	(R) $\frac{5}{2}RT$
(D) Total internal energy of 1 mole of a diatomic gas	(S) $\frac{3}{2}k_B T$

- (1) (A) - (R), (B) - (Q), (C) - (P), (D) - (S)
- (2) (A) - (R), (B) - (P), (C) - (S), (D) - (Q)
- (3) (A) - (Q), (B) - (R), (C) - (S), (D) - (P)
- (4) (A) - (Q), (B) - (P), (C) - (S), (D) - (R)

35. An electromagnetic wave of wavelength ' $\lambda$ ' is incident on a photosensitive surface of negligible work function. If ' $m$ ' mass is of photoelectron emitted from the surface has de-Broglie wavelength  $\lambda_d$ , then :

- (1)  $\lambda = \left(\frac{2h}{mc}\right)\lambda_d^2$
- (2)  $\lambda = \left(\frac{2m}{hc}\right)\lambda_d^2$
- (3)  $\lambda_d = \left(\frac{2mc}{h}\right)\lambda^2$
- (4)  $\lambda = \left(\frac{2mc}{h}\right)\lambda_d^2$

### Section - B (Physics)

36. From a circular ring of mass ' $M$ ' and radius ' $R$ ' an arc corresponding to a  $90^\circ$  sector is removed. The moment of inertia of the remaining part of the ring about an axis passing through the centre of the ring and perpendicular to the plane of the ring is ' $K$ ' times ' $MR^2$ '. Then the value of ' $K$ ' is :

- (1)  $\frac{1}{8}$
- (2)  $\frac{3}{4}$
- (3)  $\frac{7}{8}$
- (4)  $\frac{1}{4}$

37. A point object is placed at a distance of 60 cm from a convex lens of focal length 30 cm. If a plane mirror were put perpendicular to the principal axis of the lens and at a distance of 40 cm from it, the final image would be formed at a distance of :

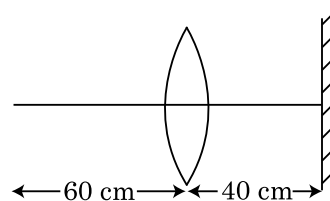

- (1) 20 cm from the plane mirror, it would be a virtual image.
- (2) 20 cm from the lens, it would be a real image.
- (3) 30 cm from the lens, it would be a real image.
- (4) 30 cm from the plane mirror, it would be a virtual image.

38. For the given circuit, the input digital signals are applied at the terminals A, B and C. What would be the output at the terminal y?

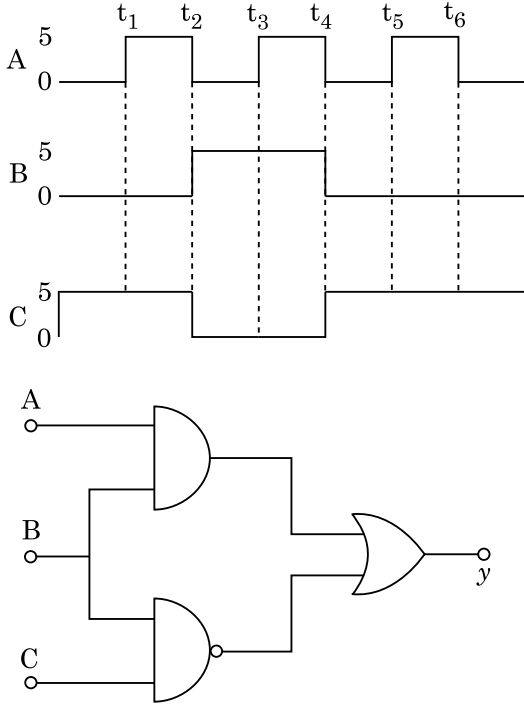

- (1)
- (2)
- (3)
- (4)

39. A car starts from rest and accelerates at  $5 \text{ m/s}^2$ . At  $t = 4 \text{ s}$ , a ball is dropped out of a window by a person sitting in the car. What is the velocity and acceleration of the ball at  $t = 6 \text{ s}$ ? (Take  $g = 10 \text{ m/s}^2$ )

- (1)  $20\sqrt{2} \text{ m/s}, 10 \text{ m/s}^2$
- (2)  $20 \text{ m/s}, 5 \text{ m/s}^2$
- (3)  $20 \text{ m/s}, 0$
- (4)  $20\sqrt{2} \text{ m/s}, 0$

40. A uniform rod of length 200 cm and mass 500 g is balanced on a wedge placed at 40 cm mark. A mass of 2 kg is suspended from the rod at 20 cm and another unknown mass 'm' is suspended from the rod at 160 cm as shown in the figure. Find the value of 'm' such that the rod is in equilibrium. ( $g = 10 \text{ m/s}^2$ )

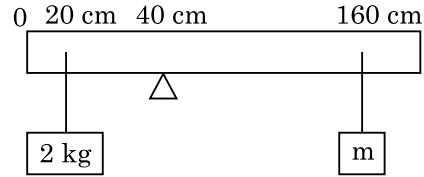

- (1)  $\frac{1}{12} \text{ kg}$
- (2)  $\frac{1}{2} \text{ kg}$
- (3)  $\frac{1}{3} \text{ kg}$
- (4)  $\frac{1}{6} \text{ kg}$
41. Two conducting circular loops of radii  $R_1$  and  $R_2$  are placed in the same plane with their centres coinciding. If  $R_1 \gg R_2$ , the mutual inductance  $M$  between them will be directly proportional to :

- (1)  $\frac{R_2^2}{R_1}$
- (2)  $\frac{R_1}{R_2}$
- (3)  $\frac{R_2}{R_1}$
- (4)  $\frac{R_1^2}{R_2}$

42. Three resistors having resistances  $r_1, r_2$  and  $r_3$  are connected as shown in the given circuit. The ratio  $\frac{i_3}{i_1}$  of currents in terms of resistances used in the circuit is :

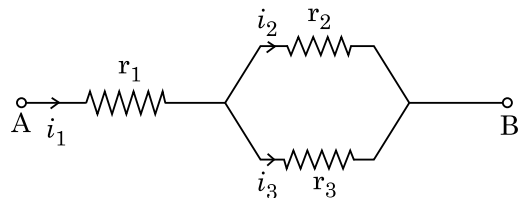

- (1)  $\frac{r_2}{r_1 + r_3}$
- (2)  $\frac{r_1}{r_2 + r_3}$
- (3)  $\frac{r_2}{r_2 + r_3}$
- (4)  $\frac{r_1}{r_1 + r_2}$

43. A particle of mass 'm' is projected with a velocity  $v = kV_e$  ( $k < 1$ ) from the surface of the earth.

( $V_e$  = escape velocity)

The maximum height above the surface reached by the particle is :

(1)  $\frac{Rk^2}{1-k^2}$

(2)  $R\left(\frac{k}{1-k}\right)^2$

(3)  $R\left(\frac{k}{1+k}\right)^2$

(4)  $\frac{R^2k}{1+k}$

44. A uniform conducting wire of length  $12a$  and resistance 'R' is wound up as a current carrying coil in the shape of,

(i) an equilateral triangle of side 'a'.

(ii) a square of side 'a'.

The magnetic dipole moments of the coil in each case respectively are :

(1)  $4 Ia^2$  and  $3 Ia^2$

(2)  $\sqrt{3} Ia^2$  and  $3 Ia^2$

(3)  $3 Ia^2$  and  $Ia^2$

(4)  $3 Ia^2$  and  $4 Ia^2$

45. A step down transformer connected to an ac mains supply of 220 V is made to operate at 11 V, 44 W lamp. Ignoring power losses in the transformer, what is the current in the primary circuit ?

(1) 4 A

(2) 0.2 A

(3) 0.4 A

(4) 2 A

46. A series LCR circuit containing 5.0 H inductor,  $80 \mu\text{F}$  capacitor and  $40 \Omega$  resistor is connected to 230 V variable frequency ac source. The angular frequencies of the source at which power transferred to the circuit is half the power at the resonant angular frequency are likely to be :

(1) 42 rad/s and 58 rad/s

(2) 25 rad/s and 75 rad/s

(3) 50 rad/s and 25 rad/s

(4) 46 rad/s and 54 rad/s

47. Twenty seven drops of same size are charged at 220 V each. They combine to form a bigger drop. Calculate the potential of the bigger drop.

(1) 1980 V

(2) 660 V

(3) 1320 V

(4) 1520 V

48. A ball of mass 0.15 kg is dropped from a height 10 m, strikes the ground and rebounds to the same height. The magnitude of impulse imparted to the ball is ( $g = 10 \text{ m/s}^2$ ) nearly :

(1) 1.4 kg m/s

(2) 0 kg m/s

(3) 4.2 kg m/s

(4) 2.1 kg m/s

49. In the product

$$\vec{F} = q \left( \vec{v} \times \vec{B} \right)$$

$$= q v \times \left( B \hat{i} + B \hat{j} + B_0 \hat{k} \right)$$

For  $q = 1$  and  $\vec{v} = 2 \hat{i} + 4 \hat{j} + 6 \hat{k}$  and

$$\vec{F} = 4 \hat{i} - 20 \hat{j} + 12 \hat{k}$$

What will be the complete expression for  $\vec{B}$  ?

(1)  $6 \hat{i} + 6 \hat{j} - 8 \hat{k}$

(2)  $-8 \hat{i} - 8 \hat{j} - 6 \hat{k}$

(3)  $-6 \hat{i} - 6 \hat{j} - 8 \hat{k}$

(4)  $8 \hat{i} + 8 \hat{j} - 6 \hat{k}$

50. A particle moving in a circle of radius R with a uniform speed takes a time T to complete one revolution.

If this particle were projected with the same speed at an angle ' $\theta$ ' to the horizontal, the maximum height attained by it equals 4R. The angle of projection,  $\theta$ , is then given by :

(1)  $\theta = \sin^{-1} \left( \frac{2gT^2}{\pi^2 R} \right)^{1/2}$

(2)  $\theta = \cos^{-1} \left( \frac{gT^2}{\pi^2 R} \right)^{1/2}$

(3)  $\theta = \cos^{-1} \left( \frac{\pi^2 R}{gT^2} \right)^{1/2}$

(4)  $\theta = \sin^{-1} \left( \frac{\pi^2 R}{gT^2} \right)^{1/2}$

### Section - A (Chemistry)

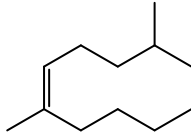
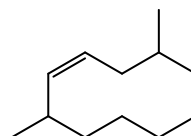
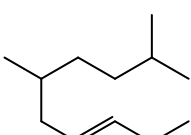
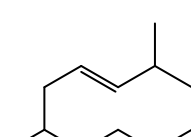
51. The molar conductance of NaCl, HCl and  $\text{CH}_3\text{COONa}$  at infinite dilution are 126.45, 426.16 and  $91.0 \text{ S cm}^2 \text{ mol}^{-1}$  respectively. The molar conductance of  $\text{CH}_3\text{COOH}$  at infinite dilution is. Choose the right option for your answer.
- (1)  $540.48 \text{ S cm}^2 \text{ mol}^{-1}$
  - (2)  $201.28 \text{ S cm}^2 \text{ mol}^{-1}$
  - (3)  $390.71 \text{ S cm}^2 \text{ mol}^{-1}$
  - (4)  $698.28 \text{ S cm}^2 \text{ mol}^{-1}$
52. What is the IUPAC name of the organic compound formed in the following chemical reaction ?
- Acetone  $\xrightarrow[\text{(ii) H}_2\text{O, H}^+]{\text{(i) C}_2\text{H}_5\text{MgBr, dry Ether}}$  Product
- (1) 2-methyl butan-2-ol
  - (2) 2-methyl propan-2-ol
  - (3) pentan-2-ol
  - (4) pentan-3-ol
53. The following solutions were prepared by dissolving 10 g of glucose ( $\text{C}_6\text{H}_{12}\text{O}_6$ ) in 250 ml of water ( $P_1$ ), 10 g of urea ( $\text{CH}_4\text{N}_2\text{O}$ ) in 250 ml of water ( $P_2$ ) and 10 g of sucrose ( $\text{C}_{12}\text{H}_{22}\text{O}_{11}$ ) in 250 ml of water ( $P_3$ ). The right option for the decreasing order of osmotic pressure of these solutions is :
- (1)  $P_3 > P_1 > P_2$
  - (2)  $P_2 > P_1 > P_3$
  - (3)  $P_1 > P_2 > P_3$
  - (4)  $P_2 > P_3 > P_1$
54. The right option for the statement "Tyndall effect is exhibited by", is :
- (1) Urea solution
  - (2) NaCl solution
  - (3) Glucose solution
  - (4) Starch solution
55. The maximum temperature that can be achieved in blast furnace is :
- (1) upto 5000 K
  - (2) upto 1200 K
  - (3) upto 2200 K
  - (4) upto 1900 K
56. The correct option for the number of body centred unit cells in all 14 types of Bravais lattice unit cells is :
- (1) 3
  - (2) 7
  - (3) 5
  - (4) 2
57. An organic compound contains 78% (by wt.) carbon and remaining percentage of hydrogen. The right option for the empirical formula of this compound is : [Atomic wt. of C is 12, H is 1]
- (1)  $\text{CH}_4$
  - (2) CH
  - (3)  $\text{CH}_2$
  - (4)  $\text{CH}_3$
58. Zr ( $Z = 40$ ) and Hf ( $Z = 72$ ) have similar atomic and ionic radii because of :
- (1) having similar chemical properties
  - (2) belonging to same group
  - (3) diagonal relationship
  - (4) lanthanoid contraction
59. Ethylene diaminetetraacetate (EDTA) ion is :
- (1) Tridentate ligand with three "N" donor atoms
  - (2) Hexadentate ligand with four "O" and two "N" donor atoms
  - (3) Unidentate ligand
  - (4) Bidentate ligand with two "N" donor atoms
60. The correct structure of 2,6-Dimethyl-dec-4-ene is :
- (1) 
  - (2) 
  - (3) 
  - (4) 
61. The RBC deficiency is deficiency disease of :
- (1) Vitamin  $\text{B}_2$
  - (2) Vitamin  $\text{B}_{12}$
  - (3) Vitamin  $\text{B}_6$
  - (4) Vitamin  $\text{B}_1$

62.  $\text{BF}_3$  is planar and electron deficient compound. Hybridization and number of electrons around the central atom, respectively are :
- (1)  $\text{sp}^2$  and 8
  - (2)  $\text{sp}^3$  and 4
  - (3)  $\text{sp}^3$  and 6
  - (4)  $\text{sp}^2$  and 6
63. Dihedral angle of least stable conformer of ethane is :
- (1)  $0^\circ$
  - (2)  $120^\circ$
  - (3)  $180^\circ$
  - (4)  $60^\circ$
64. Among the following alkaline earth metal halides, one which is covalent and soluble in organic solvents is :
- (1) Beryllium chloride
  - (2) Calcium chloride
  - (3) Strontium chloride
  - (4) Magnesium chloride
65. Which one of the following polymers is prepared by addition polymerisation ?
- (1) Dacron
  - (2) Teflon
  - (3) Nylon-66
  - (4) Novolac
66. The structures of beryllium chloride in solid state and vapour phase, are :
- (1) Chain in both
  - (2) Chain and dimer, respectively
  - (3) Linear in both
  - (4) Dimer and Linear, respectively
67. Which one of the following methods can be used to obtain highly pure metal which is liquid at room temperature ?
- (1) Zone refining
  - (2) Electrolysis
  - (3) Chromatography
  - (4) Distillation
68. Which one among the following is the correct option for right relationship between  $C_P$  and  $C_V$  for one mole of ideal gas ?
- (1)  $C_V = RC_P$
  - (2)  $C_P + C_V = R$
  - (3)  $C_P - C_V = R$
  - (4)  $C_P = RC_V$
69. Tritium, a radioactive isotope of hydrogen, emits which of the following particles ?
- (1) Neutron (n)
  - (2) Beta ( $\beta^-$ )
  - (3) Alpha ( $\alpha$ )
  - (4) Gamma ( $\gamma$ )
70. The major product formed in dehydrohalogenation reaction of 2-Bromo pentane is Pent-2-ene. This product formation is based on ?
- (1) Huckel's Rule
  - (2) Saytzeff's Rule
  - (3) Hund's Rule
  - (4) Hofmann Rule
71. A particular station of All India Radio, New Delhi, broadcasts on a frequency of 1,368 kHz (kilohertz). The wavelength of the electromagnetic radiation emitted by the transmitter is : [speed of light,  $c = 3.0 \times 10^8 \text{ ms}^{-1}$ ]
- (1) 21.92 cm
  - (2) 219.3 m
  - (3) 219.2 m
  - (4) 2192 m
72. Right option for the number of tetrahedral and octahedral voids in hexagonal primitive unit cell are :
- (1) 12, 6
  - (2) 8, 4
  - (3) 6, 12
  - (4) 2, 1
73. Identify the compound that will react with Hinsberg's reagent to give a solid which dissolves in alkali.
- (1)
  - (2)
  - (3)
  - (4)

74. The  $pK_b$  of dimethylamine and  $pK_a$  of acetic acid are 3.27 and 4.77 respectively at T (K). The correct option for the pH of dimethylammonium acetate solution is :

- (1) 6.25
- (2) 8.50
- (3) 5.50
- (4) 7.75

75. The major product of the following chemical reaction is :

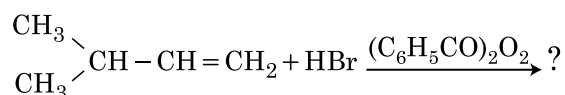

- (1)  $\begin{array}{l} \text{CH}_3 \\ \diagdown \\ \text{CBr} - \text{CH}_2 - \text{CH}_3 \\ \diagup \\ \text{CH}_3 \end{array}$
- (2)  $\begin{array}{l} \text{CH}_3 \\ \diagdown \\ \text{CH} - \text{CH}_2 - \text{CH}_2 - \text{Br} \\ \diagup \\ \text{CH}_3 \end{array}$
- (3)  $\begin{array}{l} \text{CH}_3 \\ \diagdown \\ \text{CH} - \text{CH}_2 - \text{CH}_2 - \text{O} - \text{COC}_6\text{H}_5 \\ \diagup \\ \text{CH}_3 \end{array}$
- (4)  $\begin{array}{l} \text{CH}_3 \\ \diagdown \\ \text{CH} - \text{CH} - \text{CH}_3 \\ \diagup \quad | \\ \text{CH}_3 \quad \text{Br} \end{array}$

76. Match List - I with List - II.

- | List - I           | List - II                 |
|--------------------|---------------------------|
| (a) $\text{PCl}_5$ | (i) Square pyramidal      |
| (b) $\text{SF}_6$  | (ii) Trigonal planar      |
| (c) $\text{BrF}_5$ | (iii) Octahedral          |
| (d) $\text{BF}_3$  | (iv) Trigonal bipyramidal |

Choose the **correct** answer from the options given below.

- (1) (a)-(iv), (b)-(iii), (c)-(ii), (d)-(i)
- (2) (a)-(iv), (b)-(iii), (c)-(i), (d)-(ii)
- (3) (a)-(ii), (b)-(iii), (c)-(iv), (d)-(i)
- (4) (a)-(iii), (b)-(i), (c)-(iv), (d)-(ii)

77. The **incorrect** statement among the following is :

- (1) Actinoids are highly reactive metals, especially when finely divided.
- (2) Actinoid contraction is greater for element to element than Lanthanoid contraction.
- (3) Most of the trivalent Lanthanoid ions are colorless in the solid state.
- (4) Lanthanoids are good conductors of heat and electricity.

78. **Statement I :**

Acid strength increases in the order given as  $\text{HF} \ll \text{HCl} \ll \text{HBr} \ll \text{HI}$ .

**Statement II :**

As the size of the elements F, Cl, Br, I increases down the group, the bond strength of HF, HCl, HBr and HI decreases and so the acid strength increases.

In the light of the above statements, choose the **correct** answer from the options given below.

- (1) **Statement I** is incorrect but **Statement II** is true.
- (2) Both **Statement I** and **Statement II** are true.
- (3) Both **Statement I** and **Statement II** are false.
- (4) **Statement I** is correct but **Statement II** is false.

79. Noble gases are named because of their inertness towards reactivity. Identify an **incorrect** statement about them.

- (1) Noble gases have large positive values of electron gain enthalpy.
- (2) Noble gases are sparingly soluble in water.
- (3) Noble gases have very high melting and boiling points.
- (4) Noble gases have weak dispersion forces.

80. The compound which shows metamerism is :

- (1)  $\text{C}_4\text{H}_{10}\text{O}$
- (2)  $\text{C}_5\text{H}_{12}$
- (3)  $\text{C}_3\text{H}_8\text{O}$
- (4)  $\text{C}_3\text{H}_6\text{O}$

81. Choose the correct option for graphical representation of Boyle's law, which shows a graph of pressure vs. volume of a gas at different temperatures :

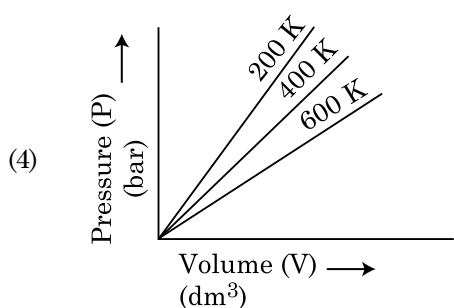
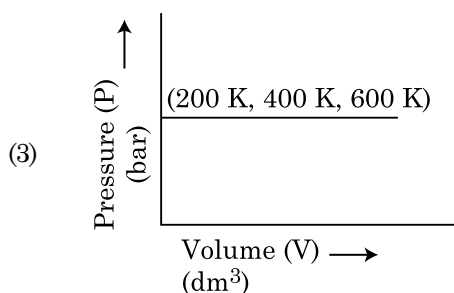
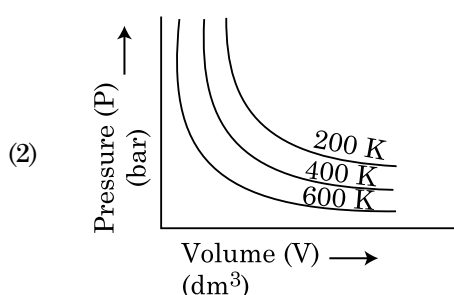
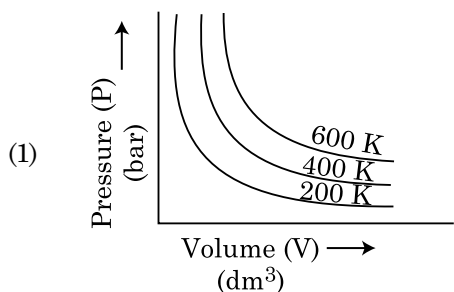

82. The correct sequence of bond enthalpy of 'C-X' bond is :

- (1)  $\text{CH}_3-\text{Cl} > \text{CH}_3-\text{F} > \text{CH}_3-\text{Br} > \text{CH}_3-\text{I}$
- (2)  $\text{CH}_3-\text{F} < \text{CH}_3-\text{Cl} < \text{CH}_3-\text{Br} < \text{CH}_3-\text{I}$
- (3)  $\text{CH}_3-\text{F} > \text{CH}_3-\text{Cl} > \text{CH}_3-\text{Br} > \text{CH}_3-\text{I}$
- (4)  $\text{CH}_3-\text{F} < \text{CH}_3-\text{Cl} > \text{CH}_3-\text{Br} > \text{CH}_3-\text{I}$

83. Given below are two statements :

**Statement I :**

Aspirin and Paracetamol belong to the class of narcotic analgesics.

**Statement II :**

Morphine and Heroin are non-narcotic analgesics.

In the light of the above statements, choose the **correct** answer from the options given below.

- (1) **Statement I** is incorrect but **Statement II** is true.
  - (2) Both **Statement I** and **Statement II** are true.
  - (3) Both **Statement I** and **Statement II** are false.
  - (4) **Statement I** is correct but **Statement II** is false.
84. For a reaction  $\text{A} \rightarrow \text{B}$ , enthalpy of reaction is  $-4.2 \text{ kJ mol}^{-1}$  and enthalpy of activation is  $9.6 \text{ kJ mol}^{-1}$ . The correct potential energy profile for the reaction is shown in option.

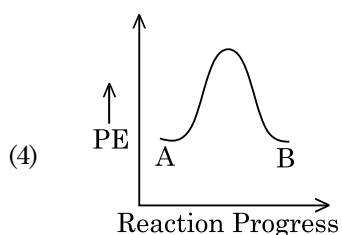
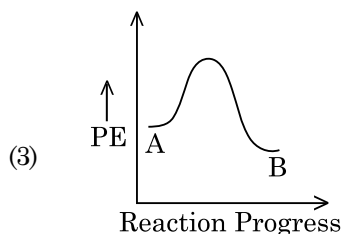
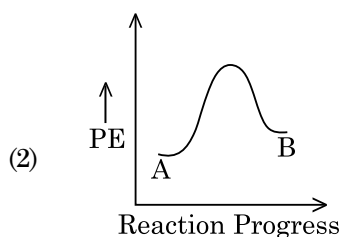
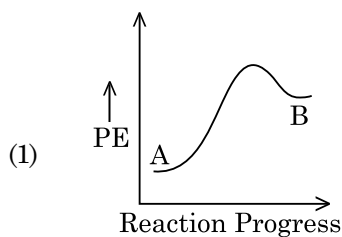



85. Which of the following reactions is the metal displacement reaction? Choose the right option.

- (1)  $2\text{Pb}(\text{NO}_3)_2 \rightarrow 2\text{PbO} + 4\text{NO}_2 + \text{O}_2 \uparrow$
- (2)  $2\text{KClO}_3 \xrightarrow{\Delta} 2\text{KCl} + 3\text{O}_2$
- (3)  $\text{Cr}_2\text{O}_3 + 2\text{Al} \xrightarrow{\Delta} \text{Al}_2\text{O}_3 + 2\text{Cr}$
- (4)  $\text{Fe} + 2\text{HCl} \rightarrow \text{FeCl}_2 + \text{H}_2 \uparrow$

### Section - B (Chemistry)

86. The slope of Arrhenius Plot  $\left(\ln k \text{ v/s } \frac{1}{T}\right)$  of first order reaction is  $-5 \times 10^3 \text{ K}$ . The value of  $E_a$  of the reaction is. Choose the correct option for your answer.

[Given  $R = 8.314 \text{ JK}^{-1}\text{mol}^{-1}$ ]

- (1)  $-83 \text{ kJ mol}^{-1}$
- (2)  $41.5 \text{ kJ mol}^{-1}$
- (3)  $83.0 \text{ kJ mol}^{-1}$
- (4)  $166 \text{ kJ mol}^{-1}$

87. Match List - I with List - II.

List - I	List - II
(a) $2\text{SO}_2(\text{g}) + \text{O}_2(\text{g}) \rightarrow 2\text{SO}_3(\text{g})$	(i) Acid rain
(b) $\text{HOCl}(\text{g}) \xrightarrow{h\nu} \begin{matrix} \cdot \\ \text{O} \\ \text{H} + \cdot \\ \text{Cl} \end{matrix}$	(ii) Smog
(c) $\text{CaCO}_3 + \text{H}_2\text{SO}_4 \rightarrow \text{CaSO}_4 + \text{H}_2\text{O} + \text{CO}_2$	(iii) Ozone depletion
(d) $\text{NO}_2(\text{g}) \xrightarrow{h\nu} \text{NO}(\text{g}) + \text{O}(\text{g})$	(iv) Tropospheric pollution

Choose the **correct** answer from the options given below.

- (1) (a)-(iii), (b)-(ii), (c)-(iv), (d)-(i)
- (2) (a)-(i), (b)-(ii), (c)-(iii), (d)-(iv)
- (3) (a)-(ii), (b)-(iii), (c)-(iv), (d)-(i)
- (4) (a)-(iv), (b)-(iii), (c)-(i), (d)-(ii)

88. Match List - I with List - II.

List - I	List - II
(a)  $\xrightarrow[\text{CuCl}]{\text{CO, HCl, Anhyd. AlCl}_3}$	(i) Hell-Volhard-Zelinsky reaction
(b) $\text{R}-\overset{\text{O}}{\parallel}{\text{C}}-\text{CH}_3 + \text{NaOX} \longrightarrow$	(ii) Gattermann-Koch reaction
(c) $\text{R}-\text{CH}_2-\text{OH} + \text{R}'\text{COOH} \xrightarrow{\text{Conc. H}_2\text{SO}_4}$	(iii) Haloform reaction
(d) $\text{R}-\text{CH}_2\text{COOH} \xrightarrow[\text{(ii) H}_2\text{O}]{\text{(i) X}_2/\text{Red P}}$	(iv) Esterification

Choose the **correct** answer from the options given below.

- (1) (a)-(ii), (b)-(iii), (c)-(iv), (d)-(i)
- (2) (a)-(iv), (b)-(i), (c)-(ii), (d)-(iii)
- (3) (a)-(iii), (b)-(ii), (c)-(i), (d)-(iv)
- (4) (a)-(i), (b)-(iv), (c)-(iii), (d)-(ii)

89. From the following pairs of ions which one is not an iso-electronic pair?

- (1)  $\text{Fe}^{2+}, \text{Mn}^{2+}$
- (2)  $\text{O}^{2-}, \text{F}^-$
- (3)  $\text{Na}^+, \text{Mg}^{2+}$
- (4)  $\text{Mn}^{2+}, \text{Fe}^{3+}$

90. The molar conductivity of 0.007 M acetic acid is  $20 \text{ S cm}^2 \text{ mol}^{-1}$ . What is the dissociation constant of acetic acid? Choose the correct option.

$$\left[ \begin{array}{l} \Lambda_{\text{H}^+}^\circ = 350 \text{ S cm}^2 \text{ mol}^{-1} \\ \Lambda_{\text{CH}_3\text{COO}^-}^\circ = 50 \text{ S cm}^2 \text{ mol}^{-1} \end{array} \right]$$

- (1)  $2.50 \times 10^{-5} \text{ mol L}^{-1}$
- (2)  $1.75 \times 10^{-4} \text{ mol L}^{-1}$
- (3)  $2.50 \times 10^{-4} \text{ mol L}^{-1}$
- (4)  $1.75 \times 10^{-5} \text{ mol L}^{-1}$

91. In which one of the following arrangements the given sequence is not strictly according to the properties indicated against it?

- (1)  $\text{CO}_2 < \text{SiO}_2 < \text{SnO}_2 < \text{PbO}_2$  : Increasing oxidizing power
- (2)  $\text{HF} < \text{HCl} < \text{HBr} < \text{HI}$  : Increasing acidic strength
- (3)  $\text{H}_2\text{O} < \text{H}_2\text{S} < \text{H}_2\text{Se} < \text{H}_2\text{Te}$  : Increasing  $\text{pK}_a$  values
- (4)  $\text{NH}_3 < \text{PH}_3 < \text{AsH}_3 < \text{SbH}_3$  : Increasing acidic character

92. The intermediate compound 'X' in the following chemical reaction is:

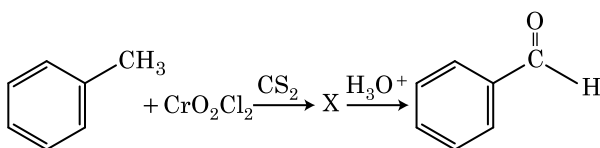

- (1)
- (2)
- (3)
- (4)

93. Which of the following molecules is non-polar in nature?

- (1)  $\text{NO}_2$
- (2)  $\text{POCl}_3$
- (3)  $\text{CH}_2\text{O}$
- (4)  $\text{SbCl}_5$

94. Match List - I with List - II.

- | List - I |  | List - II |         |
|----------|--|-----------|---------|
| (a)      | $[\text{Fe}(\text{CN})_6]^{3-}$          | (i)       | 5.92 BM |
| (b)      | $[\text{Fe}(\text{H}_2\text{O})_6]^{3+}$ | (ii)      | 0 BM    |
| (c)      | $[\text{Fe}(\text{CN})_6]^{4-}$          | (iii)     | 4.90 BM |
| (d)      | $[\text{Fe}(\text{H}_2\text{O})_6]^{2+}$ | (iv)      | 1.73 BM |

Choose the **correct** answer from the options given below.

- (1) (a)-(iv), (b)-(i), (c)-(ii), (d)-(iii)
- (2) (a)-(iv), (b)-(ii), (c)-(i), (d)-(iii)
- (3) (a)-(ii), (b)-(iv), (c)-(iii), (d)-(i)
- (4) (a)-(i), (b)-(iii), (c)-(iv), (d)-(ii)

95.  $\text{CH}_3\text{CH}_2\text{COO}^- \text{Na}^+ \xrightarrow[\text{Heat}]{\text{NaOH, + ?}} \text{CH}_3\text{CH}_3 + \text{Na}_2\text{CO}_3$ .

Consider the above reaction and identify the missing reagent/chemical.

- (1) DIBAL-H
- (2)  $\text{B}_2\text{H}_6$
- (3) Red Phosphorus
- (4) CaO

96. The product formed in the following chemical reaction is:

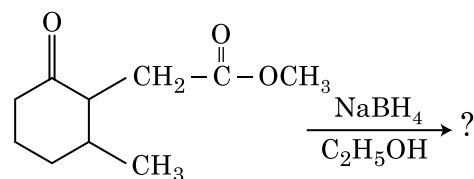

- (1)
- (2)
- (3)
- (4)

97. The correct option for the value of vapour pressure of a solution at  $45^\circ\text{C}$  with benzene to octane in molar ratio 3 : 2 is:

[At  $45^\circ\text{C}$  vapour pressure of benzene is 280 mm Hg and that of octane is 420 mm Hg. Assume Ideal gas]

- (1) 350 mm of Hg
- (2) 160 mm of Hg
- (3) 168 mm of Hg
- (4) 336 mm of Hg

98. For irreversible expansion of an ideal gas under isothermal condition, the correct option is :

- (1)  $\Delta U \neq 0, \Delta S_{\text{total}} = 0$
- (2)  $\Delta U = 0, \Delta S_{\text{total}} = 0$
- (3)  $\Delta U \neq 0, \Delta S_{\text{total}} \neq 0$
- (4)  $\Delta U = 0, \Delta S_{\text{total}} \neq 0$

99. Choose the correct option for the total pressure (in atm.) in a mixture of 4 g  $O_2$  and 2 g  $H_2$  confined in a total volume of one litre at  $0^\circ C$  is :

[Given  $R = 0.082 \text{ L atm mol}^{-1} \text{ K}^{-1}$ ,  $T = 273 \text{ K}$ ]

- (1) 26.02
- (2) 2.518
- (3) 2.602
- (4) 25.18

100. The reagent 'R' in the given sequence of chemical reaction is :

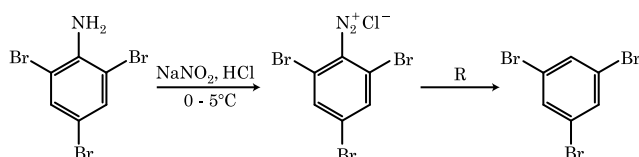

- (1)  $\text{CuCN/KCN}$
- (2)  $\text{H}_2\text{O}$
- (3)  $\text{CH}_3\text{CH}_2\text{OH}$
- (4)  $\text{HI}$

### Section - A (Biology : Botany)

101. The production of gametes by the parents, formation of zygotes, the  $F_1$  and  $F_2$  plants, can be understood from a diagram called :

- (1) Net square
- (2) Bullet square
- (3) Punch square
- (4) Punnett square

102. Gemmae are present in :

- (1) Some Liverworts
- (2) Mosses
- (3) Pteridophytes
- (4) Some Gymnosperms

103. The factor that leads to Founder effect in a population is :

- (1) Genetic drift
- (2) Natural selection
- (3) Genetic recombination
- (4) Mutation

104. Plants follow different pathways in response to environment or phases of life to form different kinds of structures. This ability is called :

- (1) Maturity
- (2) Elasticity
- (3) Flexibility
- (4) Plasticity

105. Match List - I with List - II.

List - I		List - II	
(a)	Cells with active cell division capacity	(i)	Vascular tissues
(b)	Tissue having all cells similar in structure and function	(ii)	Meristematic tissue
(c)	Tissue having different types of cells	(iii)	Sclereids
(d)	Dead cells with highly thickened walls and narrow lumen	(iv)	Simple tissue

Select the **correct** answer from the options given below.

- |     | (a)   | (b)   | (c)   | (d)   |
|-----|-------|-------|-------|-------|
| (1) | (iii) | (ii)  | (iv)  | (i)   |
| (2) | (ii)  | (iv)  | (i)   | (iii) |
| (3) | (iv)  | (iii) | (ii)  | (i)   |
| (4) | (i)   | (ii)  | (iii) | (iv)  |

106. The term used for transfer of pollen grains from anthers of one plant to stigma of a different plant which, during pollination, brings genetically different types of pollen grains to stigma, is :

- (1) Cleistogamy
- (2) Xenogamy
- (3) Geitonogamy
- (4) Chasmogamy

107. Which of the following is a **correct** sequence of steps in a PCR (Polymerase Chain Reaction) ?

- (1) Annealing, Denaturation, Extension
- (2) Denaturation, Annealing, Extension
- (3) Denaturation, Extension, Annealing
- (4) Extension, Denaturation, Annealing

108. Match List - I with List - II.

List - I		List - II	
(a)	Lenticels	(i)	Phellogen
(b)	Cork cambium	(ii)	Suberin deposition
(c)	Secondary cortex	(iii)	Exchange of gases
(d)	Cork	(iv)	Phelloderm

Choose the **correct** answer from the options given below.

- (a) (b) (c) (d)
- (1) (iv) (ii) (i) (iii)
- (2) (iv) (i) (iii) (ii)
- (3) (iii) (i) (iv) (ii)
- (4) (ii) (iii) (iv) (i)
109. In spite of interspecific competition in nature, which mechanism the competing species might have evolved for their survival ?
- (1) Predation
- (2) Resource partitioning
- (3) Competitive release
- (4) Mutualism
110. DNA strands on a gel stained with ethidium bromide when viewed under UV radiation, appear as :
- (1) Bright blue bands
- (2) Yellow bands
- (3) Bright orange bands
- (4) Dark red bands
111. Which of the following algae produce Carrageen ?
- (1) Blue-green algae
- (2) Green algae
- (3) Brown algae
- (4) Red algae
112. Diadelphous stamens are found in :
- (1) China rose and citrus
- (2) China rose
- (3) Citrus
- (4) Pea

113. The plant hormone used to destroy weeds in a field is :
- (1) IBA
- (2) IAA
- (3) NAA
- (4) 2, 4-D
114. Which of the following plants is monoecious ?
- (1) *Cycas circinalis*
- (2) *Carica papaya*
- (3) Chara
- (4) *Marchantia polymorpha*
115. Which of the following are **not** secondary metabolites in plants ?
- (1) Rubber, gums
- (2) Morphine, codeine
- (3) Amino acids, glucose
- (4) Vinblastin, curcumin
116. Complete the flow chart on central dogma.
- (a)  $\text{DNA} \xrightarrow{(b)} \text{mRNA} \xrightarrow{(c)} (d)$
- (1) (a)-Transduction; (b)-Translation; (c)-Replication; (d)-Protein
- (2) (a)-Replication; (b)-Transcription; (c)-Transduction; (d)-Protein
- (3) (a)-Translation; (b)-Replication; (c)-Transcription; (d)-Transduction
- (4) (a)-Replication; (b)-Transcription; (c)-Translation; (d)-Protein
117. The site of perception of light in plants during photoperiodism is :
- (1) Leaf
- (2) Shoot apex
- (3) Stem
- (4) Axillary bud
118. In the equation  $GPP - R = NPP$  R represents :
- (1) Respiration losses
- (2) Radiant energy
- (3) Retardation factor
- (4) Environment factor

## 119. Match List - I with List - II.

List - I		List - II	
(a)	Cristae	(i)	Primary constriction in chromosome
(b)	Thylakoids	(ii)	Disc-shaped sacs in Golgi apparatus
(c)	Centromere	(iii)	Infoldings in mitochondria
(d)	Cisternae	(iv)	Flattened membranous sacs in stroma of plastids

Choose the **correct** answer from the options given below.

- |     | (a)   | (b)   | (c)   | (d)  |
|-----|-------|-------|-------|------|
| (1) | (ii)  | (iii) | (iv)  | (i)  |
| (2) | (iv)  | (iii) | (ii)  | (i)  |
| (3) | (i)   | (iv)  | (iii) | (ii) |
| (4) | (iii) | (iv)  | (i)   | (ii) |

## 120. Which of the following algae contains mannitol as reserve food material ?

- (1) *Ulothrix*
- (2) *Ectocarpus*
- (3) *Gracilaria*
- (4) *Volvox*

121. Which of the following is an **incorrect** statement ?

- (1) Nuclear pores act as passages for proteins and RNA molecules in both directions between nucleus and cytoplasm.
- (2) Mature sieve tube elements possess a conspicuous nucleus and usual cytoplasmic organelles.
- (3) Microbodies are present both in plant and animal cells.
- (4) The perinuclear space forms a barrier between the materials present inside the nucleus and that of the cytoplasm.

## 122. Mutations in plant cells can be induced by :

- (1) Zeatin
- (2) Kinetin
- (3) Infrared rays
- (4) Gamma rays

123. The first stable product of CO<sub>2</sub> fixation in sorghum is :

- (1) Phosphoglyceric acid
- (2) Pyruvic acid
- (3) Oxaloacetic acid
- (4) Succinic acid

## 124. Match List - I with List - II.

List - I		List - II	
(a)	Cohesion	(i)	More attraction in liquid phase
(b)	Adhesion	(ii)	Mutual attraction among water molecules
(c)	Surface tension	(iii)	Water loss in liquid phase
(d)	Guttation	(iv)	Attraction towards polar surfaces

Choose the **correct** answer from the options given below.

- |     | (a)   | (b)   | (c)  | (d)   |
|-----|-------|-------|------|-------|
| (1) | (ii)  | (i)   | (iv) | (iii) |
| (2) | (ii)  | (iv)  | (i)  | (iii) |
| (3) | (iv)  | (iii) | (ii) | (i)   |
| (4) | (iii) | (i)   | (iv) | (ii)  |

## 125. During the purification process for recombinant DNA technology, addition of chilled ethanol precipitates out :

- (1) Polysaccharides
- (2) RNA
- (3) DNA
- (4) Histones

## 126. Amensalism can be represented as :

- (1) Species A (+) ; Species B (0)
- (2) Species A (-) ; Species B (0)
- (3) Species A (+) ; Species B (+)
- (4) Species A (-) ; Species B (-)

## 127. Which of the following stages of meiosis involves division of centromere ?

- (1) Telophase II
- (2) Metaphase I
- (3) Metaphase II
- (4) Anaphase II

## 128. When gene targetting involving gene amplification is attempted in an individual's tissue to treat disease, it is known as :

- (1) Safety testing
- (2) Biopiracy
- (3) Gene therapy
- (4) Molecular diagnosis

## 129. The amount of nutrients, such as carbon, nitrogen, phosphorus and calcium present in the soil at any given time, is referred as :

- (1) Standing crop
- (2) Climax
- (3) Climax community
- (4) Standing state

130. Which of the following statements is **not** correct ?
- (1) Pyramid of numbers in a grassland ecosystem is upright.
  - (2) Pyramid of biomass in sea is generally inverted.
  - (3) Pyramid of biomass in sea is generally upright.
  - (4) Pyramid of energy is always upright.
131. A typical angiosperm embryo sac at maturity is :
- (1) 8-nucleate and 8-celled
  - (2) 8-nucleate and 7-celled
  - (3) 7-nucleate and 8-celled
  - (4) 7-nucleate and 7-celled
132. When the centromere is situated in the middle of two equal arms of chromosomes, the chromosome is referred as :
- (1) Acrocentric
  - (2) Metacentric
  - (3) Telocentric
  - (4) Sub-metacentric
133. Genera like *Selaginella* and *Salvinia* produce two kinds of spores. Such plants are known as :
- (1) Heterosporous
  - (2) Homosorus
  - (3) Heterosorus
  - (4) Homosporous
134. Match List - I with List - II.

List - I		List - II	
(a)	Protoplast fusion	(i)	Totipotency
(b)	Plant tissue culture	(ii)	Pomato
(c)	Meristem culture	(iii)	Somaclones
(d)	Micropropagation	(iv)	Virus free plants

Choose the **correct** answer from the options given below.

- |     | (a)   | (b)   | (c)  | (d)   |
|-----|-------|-------|------|-------|
| (1) | (iv)  | (iii) | (ii) | (i)   |
| (2) | (iii) | (iv)  | (ii) | (i)   |
| (3) | (ii)  | (i)   | (iv) | (iii) |
| (4) | (iii) | (iv)  | (i)  | (ii)  |
135. Which of the following is **not** an application of PCR (Polymerase Chain Reaction) ?
- (1) Detection of gene mutation
  - (2) Molecular diagnosis
  - (3) Gene amplification
  - (4) Purification of isolated protein

### Section - B (Biology : Botany)

136. Identify the **correct** statement.
- (1) Split gene arrangement is characteristic of prokaryotes.
  - (2) In capping, methyl guanosine triphosphate is added to the 3' end of hnRNA.
  - (3) RNA polymerase binds with Rho factor to terminate the process of transcription in bacteria.
  - (4) The coding strand in a transcription unit is copied to an mRNA.
137. Now a days it is possible to detect the mutated gene causing cancer by allowing radioactive probe to hybridise its complimentary DNA in a clone of cells, followed by its detection using autoradiography because :
- (1) mutated gene does not appear on photographic film as the probe has complementarity with it.
  - (2) mutated gene partially appears on a photographic film.
  - (3) mutated gene completely and clearly appears on a photographic film.
  - (4) mutated gene does not appear on a photographic film as the probe has no complementarity with it.
138. What is the role of RNA polymerase III in the process of transcription in eukaryotes ?
- (1) Transcribes only snRNAs
  - (2) Transcribes rRNAs (28S, 18S and 5.8S)
  - (3) Transcribes tRNA, 5s rRNA and snRNA
  - (4) Transcribes precursor of mRNA
139. Select the **correct** pair.
- (1) Loose parenchyma cells - Spongy rupturing the epidermis and forming a lens-shaped opening in bark
  - (2) Large colorless empty cells in the epidermis of grass leaves - Subsidiary cells
  - (3) In dicot leaves, vascular bundles are surrounded by large thick-walled cells - Conjunctive tissue
  - (4) Cells of medullary rays that form part of cambial ring - Interfascicular cambium

140. In the exponential growth equation

$$N_t = N_0 e^{rt}, e \text{ represents :}$$

- (1) The base of geometric logarithms
- (2) The base of number logarithms
- (3) The base of exponential logarithms
- (4) The base of natural logarithms

141. Which of the following statements is **incorrect** ?

- (1) Oxidation-reduction reactions produce proton gradient in respiration.
- (2) During aerobic respiration, role of oxygen is limited to the terminal stage.
- (3) In ETC (Electron Transport Chain), one molecule of  $\text{NADH} + \text{H}^+$  gives rise to 2 ATP molecules, and one  $\text{FADH}_2$  gives rise to 3 ATP molecules.
- (4) ATP is synthesized through complex V.

142. Which of the following statements is **incorrect** ?

- (1) Cyclic photophosphorylation involves both PS I and PS II.
- (2) Both ATP and  $\text{NADPH} + \text{H}^+$  are synthesized during non-cyclic photophosphorylation.
- (3) Stroma lamellae have PS I only and lack NADP reductase.
- (4) Grana lamellae have both PS I and PS II.

143. Which of the following statements is **correct** ?

- (1) Some of the organisms can fix atmospheric nitrogen in specialized cells called sheath cells.
- (2) Fusion of two cells is called Karyogamy.
- (3) Fusion of protoplasts between two motile non-motile gametes is called plasmogamy.
- (4) Organisms that depend on living plants are called saprophytes.

144. DNA fingerprinting involves identifying differences in some specific regions in DNA sequence, called as :

- (1) Polymorphic DNA
- (2) Satellite DNA
- (3) Repetitive DNA
- (4) Single nucleotides

145. Match List - I with List - II.

	List - I		List - II
(a)	Protein	(i)	C = C double bonds
(b)	Unsaturated fatty acid	(ii)	Phosphodiester bonds
(c)	Nucleic acid	(iii)	Glycosidic bonds
(d)	Polysaccharide	(iv)	Peptide bonds

Choose the **correct** answer from the options given below.

- |     | (a)  | (b)   | (c)   | (d)   |
|-----|------|-------|-------|-------|
| (1) | (iv) | (iii) | (i)   | (ii)  |
| (2) | (iv) | (i)   | (ii)  | (iii) |
| (3) | (i)  | (iv)  | (iii) | (ii)  |
| (4) | (ii) | (i)   | (iv)  | (iii) |

146. Match Column - I with Column - II.

	Column - I		Column - II
(a)	<i>Nitrococcus</i>	(i)	Denitrification
(b)	<i>Rhizobium</i>	(ii)	Conversion of ammonia to nitrite
(c)	<i>Thiobacillus</i>	(iii)	Conversion of nitrite to nitrate
(d)	<i>Nitrobacter</i>	(iv)	Conversion of atmospheric nitrogen to ammonia

Choose the **correct** answer from options given below.

- |     | (a)   | (b)   | (c)   | (d)   |
|-----|-------|-------|-------|-------|
| (1) | (iv)  | (iii) | (ii)  | (i)   |
| (2) | (ii)  | (iv)  | (i)   | (iii) |
| (3) | (i)   | (ii)  | (iii) | (iv)  |
| (4) | (iii) | (i)   | (iv)  | (ii)  |

147. In some members of which of the following pairs of families, pollen grains retain their viability for months after release ?

- (1) Rosaceae ; Leguminosae
- (2) Poaceae ; Rosaceae
- (3) Poaceae ; Leguminosae
- (4) Poaceae ; Solanaceae

148. Plasmid pBR322 has PstI restriction enzyme site within gene  $amp^R$  that confers ampicillin resistance. If this enzyme is used for inserting a gene for  $\beta$ -galactoside production and the recombinant plasmid is inserted in an *E.coli* strain

- (1) it will be able to produce a novel protein with dual ability.
- (2) it will not be able to confer ampicillin resistance to the host cell.
- (3) the transformed cells will have the ability to resist ampicillin as well as produce  $\beta$ -galactoside.
- (4) it will lead to lysis of host cell.

149. Match Column - I with Column - II.

Column - I	Column - II
(a) $\% \frac{\text{♂}}{\text{♀}} K_{(5)} C_{1+2+(2)} A_{(9)+1} G_{1}$	(i) Brassicaceae
(b) $\oplus \frac{\text{♂}}{\text{♀}} K_{(5)} \widehat{C_{(5)} A_5} G_{2}$	(ii) Liliaceae
(c) $\oplus \frac{\text{♂}}{\text{♀}} \widehat{P_{(3+3)} A_{3+3}} G_{(3)}$	(iii) Fabaceae
(d) $\oplus \frac{\text{♂}}{\text{♀}} K_{2+2} C_4 A_{2-4} G_{(2)}$	(iv) Solanaceae

Select the **correct** answer from the options given below.

	(a)	(b)	(c)	(d)
(1)	(iv)	(ii)	(i)	(iii)
(2)	(iii)	(iv)	(ii)	(i)
(3)	(i)	(ii)	(iii)	(iv)
(4)	(ii)	(iii)	(iv)	(i)

150. Match List - I with List - II.

List - I		List - II	
(a)	S phase	(i)	Proteins are synthesized
(b)	G <sub>2</sub> phase	(ii)	Inactive phase
(c)	Quiescent stage	(iii)	Interval between mitosis and initiation of DNA replication
(d)	G <sub>1</sub> phase	(iv)	DNA replication

Choose the **correct** answer from the options given below.

	(a)	(b)	(c)	(d)
(1)	(ii)	(iv)	(iii)	(i)
(2)	(iii)	(ii)	(i)	(iv)
(3)	(iv)	(ii)	(iii)	(i)
(4)	(iv)	(i)	(ii)	(iii)

**Section - A (Biology : Zoology)**

151. Which of the following RNAs is not required for the synthesis of protein ?

- (1) siRNA
- (2) mRNA
- (3) tRNA
- (4) rRNA

152. Succus entericus is referred to as :

- (1) Chyme
- (2) Pancreatic juice
- (3) Intestinal juice
- (4) Gastric juice

153. Which is the "Only enzyme" that has "Capability" to catalyse Initiation, Elongation and Termination in the process of transcription in prokaryotes ?

- (1) DNase
- (2) DNA dependent DNA polymerase
- (3) DNA dependent RNA polymerase
- (4) DNA Ligase

154. Which of the following characteristics is **incorrect** with respect to cockroach ?

- (1) 10<sup>th</sup> abdominal segment in both sexes, bears a pair of anal cerci.
- (2) A ring of gastric caeca is present at the junction of midgut and hind gut.
- (3) Hypopharynx lies within the cavity enclosed by the mouth parts.
- (4) In females, 7<sup>th</sup>-9<sup>th</sup> sterna together form a genital pouch.

155. Match List - I with List - II.

List - I		List - II	
(a)	Metamerism	(i)	Coelenterata
(b)	Canal system	(ii)	Ctenophora
(c)	Comb plates	(iii)	Annelida
(d)	Cnidoblasts	(iv)	Porifera

Choose the **correct** answer from the options given below.

	(a)	(b)	(c)	(d)
(1)	(iv)	(i)	(ii)	(iii)
(2)	(iv)	(iii)	(i)	(ii)
(3)	(iii)	(iv)	(i)	(ii)
(4)	(iii)	(iv)	(ii)	(i)



156. Which of the following is **not** an objective of Biofortification in crops ?

- (1) Improve micronutrient and mineral content
- (2) Improve protein content
- (3) Improve resistance to diseases
- (4) Improve vitamin content

157. Identify the **incorrect** pair.

- (1) Drugs - Ricin
- (2) Alkaloids - Codeine
- (3) Toxin - Abrin
- (4) Lectins - Concanavalin A

158. Match List - I with List - II.

List - I		List - II	
(a)	<i>Aspergillus niger</i>	(i)	Acetic Acid
(b)	<i>Acetobacter aceti</i>	(ii)	Lactic Acid
(c)	<i>Clostridium butylicum</i>	(iii)	Citric Acid
(d)	<i>Lactobacillus</i>	(iv)	Butyric Acid

Choose the **correct** answer from the options given below.

- |     |            |            |            |            |
|-----|------------|------------|------------|------------|
|     | <b>(a)</b> | <b>(b)</b> | <b>(c)</b> | <b>(d)</b> |
| (1) | (iv)       | (ii)       | (i)        | (iii)      |
| (2) | (iii)      | (i)        | (iv)       | (ii)       |
| (3) | (i)        | (ii)       | (iii)      | (iv)       |
| (4) | (ii)       | (iii)      | (i)        | (iv)       |

159. With regard to insulin choose correct options.

- (a) C-peptide is not present in mature insulin.
- (b) The insulin produced by rDNA technology has C-peptide.
- (c) The pro-insulin has C-peptide.
- (d) A-peptide and B-peptide of insulin are interconnected by disulphide bridges.

Choose the **correct** answer from the options given below.

- (1) (a) and (d) only
- (2) (b) and (d) only
- (3) (b) and (c) only
- (4) (a), (c) and (d) only

160. Select the favourable conditions required for the formation of oxyhaemoglobin at the alveoli.

- (1) Low  $pO_2$ , low  $pCO_2$ , more  $H^+$ , higher temperature
- (2) High  $pO_2$ , low  $pCO_2$ , less  $H^+$ , lower temperature
- (3) Low  $pO_2$ , high  $pCO_2$ , more  $H^+$ , higher temperature
- (4) High  $pO_2$ , high  $pCO_2$ , less  $H^+$ , higher temperature

161. Match the following :

List - I		List - II	
(a)	<i>Physalia</i>	(i)	Pearl oyster
(b)	<i>Limulus</i>	(ii)	Portuguese Man of War
(c)	<i>Ancylostoma</i>	(iii)	Living fossil
(d)	<i>Pinctada</i>	(iv)	Hookworm

Choose the **correct** answer from the options given below.

- |     |            |            |            |            |
|-----|------------|------------|------------|------------|
|     | <b>(a)</b> | <b>(b)</b> | <b>(c)</b> | <b>(d)</b> |
| (1) | (i)        | (iv)       | (iii)      | (ii)       |
| (2) | (ii)       | (iii)      | (i)        | (iv)       |
| (3) | (iv)       | (i)        | (iii)      | (ii)       |
| (4) | (ii)       | (iii)      | (iv)       | (i)        |

162. The fruit fly has 8 chromosomes ( $2n$ ) in each cell. During interphase of Mitosis if the number of chromosomes at  $G_1$  phase is 8, what would be the number of chromosomes after S phase ?

- (1) 32
- (2) 8
- (3) 16
- (4) 4

163. Which one of the following organisms bears hollow and pneumatic long bones ?

- (1) *Ornithorhynchus*
- (2) *Neophron*
- (3) *Hemidactylus*
- (4) *Macropus*

164. Dobson units are used to measure thickness of :

- (1) Troposphere
- (2) CFCs
- (3) Stratosphere
- (4) Ozone

165. Which enzyme is responsible for the conversion of inactive fibrinogens to fibrins ?

- (1) Thrombokinase
- (2) Thrombin
- (3) Renin
- (4) Epinephrine

166. For effective treatment of the disease, early diagnosis and understanding its pathophysiology is very important. Which of the following molecular diagnostic techniques is very useful for early detection ?

- (1) Hybridization Technique
- (2) Western Blotting Technique
- (3) Southern Blotting Technique
- (4) ELISA Technique

- 167.** The organelles that are included in the endomembrane system are :
- (1) Golgi complex, Endoplasmic reticulum, Mitochondria and Lysosomes
  - (2) Endoplasmic reticulum, Mitochondria, Ribosomes and Lysosomes
  - (3) Endoplasmic reticulum, Golgi complex, Lysosomes and Vacuoles
  - (4) Golgi complex, Mitochondria, Ribosomes and Lysosomes
- 168.** If Adenine makes 30% of the DNA molecule, what will be the percentage of Thymine, Guanine and Cytosine in it ?
- (1) T : 20 ; G : 25 ; C : 25
  - (2) T : 20 ; G : 30 ; C : 20
  - (3) T : 20 ; G : 20 ; C : 30
  - (4) T : 30 ; G : 20 ; C : 20
- 169.** A specific recognition sequence identified by endonucleases to make cuts at specific positions within the DNA is :
- (1) Poly(A) tail sequences
  - (2) Degenerate primer sequence
  - (3) Okazaki sequences
  - (4) Palindromic Nucleotide sequences
- 170.** Which of the following statements wrongly represents the nature of smooth muscle ?
- (1) These muscles are present in the wall of blood vessels
  - (2) These muscle have no striations
  - (3) They are involuntary muscles
  - (4) Communication among the cells is performed by intercalated discs
- 171.** Match List - I with List - II.

List - I		List - II	
(a)	Vaults	(i)	Entry of sperm through Cervix is blocked
(b)	IUDs	(ii)	Removal of Vas deferens
(c)	Vasectomy	(iii)	Phagocytosis of sperms within the Uterus
(d)	Tubectomy	(iv)	Removal of fallopian tube

Choose the **correct** answer from the options given below.

- |     |            |            |            |            |
|-----|------------|------------|------------|------------|
|     | <b>(a)</b> | <b>(b)</b> | <b>(c)</b> | <b>(d)</b> |
| (1) | (iii)      | (i)        | (iv)       | (ii)       |
| (2) | (iv)       | (ii)       | (i)        | (iii)      |
| (3) | (i)        | (iii)      | (ii)       | (iv)       |
| (4) | (ii)       | (iv)       | (iii)      | (i)        |

- 172.** During the process of gene amplification using PCR, if very high temperature is not maintained in the beginning, then which of the following steps of PCR will be affected first ?
- (1) Ligation
  - (2) Annealing
  - (3) Extension
  - (4) Denaturation
- 173.** In a cross between a male and female, both heterozygous for sickle cell anaemia gene, what percentage of the progeny will be diseased ?
- (1) 100%
  - (2) 50%
  - (3) 75%
  - (4) 25%
- 174.** Read the following statements.
- (a) Metagenesis is observed in Helminths.
  - (b) Echinoderms are triploblastic and coelomate animals.
  - (c) Round worms have organ-system level of body organization.
  - (d) Comb plates present in ctenophores help in digestion.
  - (e) Water vascular system is characteristic of Echinoderms.

Choose the **correct** answer from the options given below.

- (1) (b), (c) and (e) are correct
- (2) (c), (d) and (e) are correct
- (3) (a), (b) and (c) are correct
- (4) (a), (d) and (e) are correct

- 175.** Receptors for sperm binding in mammals are present on :

- (1) Zona pellucida
- (2) Corona radiata
- (3) Vitelline membrane
- (4) Perivitelline space

176. Sphincter of oddi is present at :
- (1) Junction of jejunum and duodenum
  - (2) Ileo-caecal junction
  - (3) Junction of hepato-pancreatic duct and duodenum
  - (4) Gastro-oesophageal junction
177. Chronic auto immune disorder affecting neuro muscular junction leading to fatigue, weakening and paralysis of skeletal muscle is called as :
- (1) Gout
  - (2) Arthritis
  - (3) Muscular dystrophy
  - (4) Myasthenia gravis
178. Persons with 'AB' blood group are called as "Universal recipients". This is due to :
- (1) Absence of antibodies, anti-A and anti-B, in plasma
  - (2) Absence of antigens A and B on the surface of RBCs
  - (3) Absence of antigens A and B in plasma
  - (4) Presence of antibodies, anti-A and anti-B, on RBCs
179. The centriole undergoes duplication during :
- (1) G<sub>2</sub> phase
  - (2) S-phase
  - (3) Prophase
  - (4) Metaphase
180. Erythropoietin hormone which stimulates R.B.C. formation is produced by :
- (1) Juxtaglomerular cells of the kidney
  - (2) Alpha cells of pancreas
  - (3) The cells of rostral adenohypophysis
  - (4) The cells of bone marrow
181. Which one of the following belongs to the family Muscidae ?
- (1) House fly
  - (2) Fire fly
  - (3) Grasshopper
  - (4) Cockroach
182. Venereal diseases can spread through :
- (a) Using sterile needles
  - (b) Transfusion of blood from infected person
  - (c) Infected mother to foetus
  - (d) Kissing
  - (e) Inheritance
- Choose the **correct** answer from the options given below.
- (1) (a) and (c) only
  - (2) (a), (b) and (c) only
  - (3) (b), (c) and (d) only
  - (4) (b) and (c) only
183. The partial pressures (in mm Hg) of oxygen (O<sub>2</sub>) and carbon dioxide (CO<sub>2</sub>) at alveoli (the site of diffusion) are :
- (1) pO<sub>2</sub> = 159 and pCO<sub>2</sub> = 0.3
  - (2) pO<sub>2</sub> = 104 and pCO<sub>2</sub> = 40
  - (3) pO<sub>2</sub> = 40 and pCO<sub>2</sub> = 45
  - (4) pO<sub>2</sub> = 95 and pCO<sub>2</sub> = 40
184. Which one of the following is an example of Hormone releasing IUD ?
- (1) Multiload 375
  - (2) CuT
  - (3) LNG 20
  - (4) Cu 7
185. Which stage of meiotic prophase shows terminalisation of chiasmata as its distinctive feature ?
- (1) Pachytene
  - (2) Leptotene
  - (3) Zygotene
  - (4) Diakinesis

**Section - B (Biology : Zoology)**

- 186.** Which of these is not an important component of initiation of parturition in humans ?
- (1) Release of Prolactin
  - (2) Increase in estrogen and progesterone ratio
  - (3) Synthesis of prostaglandins
  - (4) Release of Oxytocin
- 187.** Following are the statements about prostomium of earthworm.
- (a) It serves as a covering for mouth.
  - (b) It helps to open cracks in the soil into which it can crawl.
  - (c) It is one of the sensory structures.
  - (d) It is the first body segment.
- Choose the **correct** answer from the options given below.
- (1) (b) and (c) are correct
  - (2) (a), (b) and (c) are correct
  - (3) (a), (b) and (d) are correct
  - (4) (a), (b), (c) and (d) are correct
- 188.** The Adenosine deaminase deficiency results into :
- (1) Addison's disease
  - (2) Dysfunction of Immune system
  - (3) Parkinson's disease
  - (4) Digestive disorder

**189.** Match List - I with List - II.

List - I		List - II	
(a)	Adaptive radiation	(i)	Selection of resistant varieties due to excessive use of herbicides and pesticides
(b)	Convergent evolution	(ii)	Bones of forelimbs in Man and Whale
(c)	Divergent evolution	(iii)	Wings of Butterfly and Bird
(d)	Evolution by anthropogenic action	(iv)	Darwin Finches

Choose the **correct** answer from the options given below.

- |     |            |            |            |            |
|-----|------------|------------|------------|------------|
|     | <b>(a)</b> | <b>(b)</b> | <b>(c)</b> | <b>(d)</b> |
| (1) | (i)        | (iv)       | (iii)      | (ii)       |
| (2) | (iv)       | (iii)      | (ii)       | (i)        |
| (3) | (iii)      | (ii)       | (i)        | (iv)       |
| (4) | (ii)       | (i)        | (iv)       | (iii)      |

- 190.** Following are the statements with reference to 'lipids'.
- (a) Lipids having only single bonds are called unsaturated fatty acids.
  - (b) Lecithin is a phospholipid.
  - (c) Trihydroxy propane is glycerol.
  - (d) Palmitic acid has 20 carbon atoms including carboxyl carbon.
  - (e) Arachidonic acid has 16 carbon atoms.
- Choose the **correct** answer from the options given below.
- (1) (b) and (e) only
  - (2) (a) and (b) only
  - (3) (c) and (d) only
  - (4) (b) and (c) only
- 191.** Which one of the following statements about Histones is **wrong** ?
- (1) Histones carry positive charge in the side chain.
  - (2) Histones are organized to form a unit of 8 molecules.
  - (3) The pH of histones is slightly acidic.
  - (4) Histones are rich in amino acids - Lysine and Arginine.
- 192.** Which of the following secretes the hormone, relaxin, during the later phase of pregnancy ?
- (1) Uterus
  - (2) Graafian follicle
  - (3) Corpus luteum
  - (4) Foetus
- 193.** Which of the following is **not** a step in Multiple Ovulation Embryo Transfer Technology (MOET) ?
- (1) Fertilized eggs are transferred to surrogate mothers at 8-32 cell stage
  - (2) Cow is administered hormone having LH like activity for super ovulation
  - (3) Cow yields about 6-8 eggs at a time
  - (4) Cow is fertilized by artificial insemination
- 194.** Identify the types of cell junctions that help to stop the leakage of the substances across a tissue and facilitation of communication with neighbouring cells via rapid transfer of ions and molecules.
- (1) Adhering junctions and Gap junctions, respectively.
  - (2) Gap junctions and Adhering junctions, respectively.
  - (3) Tight junctions and Gap junctions, respectively.
  - (4) Adhering junctions and Tight junctions, respectively.

195. Match List - I with List - II.

List - I		List - II	
(a)	Allen's Rule	(i)	Kangaroo rat
(b)	Physiological adaptation	(ii)	Desert lizard
(c)	Behavioural adaptation	(iii)	Marine fish at depth
(d)	Biochemical adaptation	(iv)	Polar seal

Choose the **correct** answer from the options given below.

- (a) (b) (c) (d)
- (1) (iv) (iii) (ii) (i)
- (2) (iv) (ii) (iii) (i)
- (3) (iv) (i) (iii) (ii)
- (4) (iv) (i) (ii) (iii)

196. Assertion (A) :

A person goes to high altitude and experiences 'altitude sickness' with symptoms like breathing difficulty and heart palpitations.

Reason (R) :

Due to low atmospheric pressure at high altitude, the body does not get sufficient oxygen.

In the light of the above statements, choose the **correct** answer from the options given below.

- (1) (A) is false but (R) is true
- (2) Both (A) and (R) are true and (R) is the correct explanation of (A)
- (3) Both (A) and (R) are true but (R) is not the correct explanation of (A)
- (4) (A) is true but (R) is false

197. Match List - I with List - II.

List - I		List - II	
(a)	Filariasis	(i)	<i>Haemophilus influenzae</i>
(b)	Amoebiasis	(ii)	<i>Trichophyton</i>
(c)	Pneumonia	(iii)	<i>Wuchereria bancrofti</i>
(d)	Ringworm	(iv)	<i>Entamoeba histolytica</i>

Choose the **correct** answer from the options given below.

- (a) (b) (c) (d)
- (1) (ii) (iii) (i) (iv)
- (2) (iv) (i) (iii) (ii)
- (3) (iii) (iv) (i) (ii)
- (4) (i) (ii) (iv) (iii)

198. Match List - I with List - II.

List - I		List - II	
(a)	Scapula	(i)	Cartilaginous joints
(b)	Cranium	(ii)	Flat bone
(c)	Sternum	(iii)	Fibrous joints
(d)	Vertebral column	(iv)	Triangular flat bone

Choose the **correct** answer from the options given below.

- (a) (b) (c) (d)
- (1) (iv) (iii) (ii) (i)
- (2) (i) (iii) (ii) (iv)
- (3) (ii) (iii) (iv) (i)
- (4) (iv) (ii) (iii) (i)

199. During muscular contraction which of the following events occur ?

- (a) 'H' zone disappears
- (b) 'A' band widens
- (c) 'I' band reduces in width
- (d) Myosine hydrolyzes ATP, releasing the ADP and Pi
- (e) Z-lines attached to actins are pulled inwards

Choose the **correct** answer from the options given below.

- (1) (b), (d), (e), (a) only
- (2) (a), (c), (d), (e) only
- (3) (a), (b), (c), (d) only
- (4) (b), (c), (d), (e) only

200. Statement I :

The codon 'AUG' codes for methionine and phenylalanine.

Statement II :

'AAA' and 'AAG' both codons code for the amino acid lysine.

In the light of the above statements, choose the **correct** answer from the options given below.

- (1) Statement I is incorrect but Statement II is true
- (2) Both Statement I and Statement II are true
- (3) Both Statement I and Statement II are false
- (4) Statement I is correct but Statement II is false

**P1**

**26**

**Space For Rough Work**

**Space For Rough Work**

**P1**

**28**

**Space For Rough Work**